



# ENGINEERING

# PHYSICS

**B.Tech (1<sup>st</sup> yr.)**

**Notes**

**Prepared By:**



# PHYSICS

## **Module - 1 Relativistic Mechanics:** [8]

Frame of reference, Inertial & non-inertial frames, Galilean transformations, MichelsonMorley experiment, Postulates of special theory of relativity, Lorentz transformations, Length contraction, Time dilation, Velocity addition theorem, Variation of mass with velocity, Einstein's mass energy relation, Relativistic relation between energy and momentum, Massless particle.

## **Module- 2 Electromagnetic Field Theory:** [8]

Continuity equation for current density, Displacement current, Modifying equation for the curl of magnetic field to satisfy continuity equation, Maxwell's equations in vacuum and in non conducting medium, Energy in an electromagnetic field, Poynting vector and Poynting theorem, Plane electromagnetic waves in vacuum and their transverse nature. Relation between electric and magnetic fields of an electromagnetic wave, Energy and momentum carried by electromagnetic waves, Resultant pressure, Skin depth.

## **Module- 3 Quantum Mechanics:** [8]

Black body radiation, Stefan's law, Wien's law, Rayleigh-Jeans law and Planck's law, Wave particle duality, Matter waves, Time-dependent and time-independent Schrodinger wave equation, Born interpretation of wave function, Solution to stationary state Schrodinger wave equation for one-Dimensional particle in a box, Compton effect.

## **Module- 4 Wave Optics:** [10]

Coherent sources, Interference in uniform and wedge shaped thin films, Necessity of extended sources, Newton's Rings and its applications. Fraunhofer diffraction at single slit and at double slit, absent spectra, Diffraction grating, Spectra with grating, Dispersive power, Resolving power of grating, Rayleigh's criterion of resolution, Resolving power of grating.

## **Module- 5 Fibre Optics & Laser:** [10]

Fibre Optics: Introduction to fibre optics, Acceptance angle, Numerical aperture, Normalized frequency, Classification of fibre, Attenuation and Dispersion in optical fibres. Laser: Absorption of radiation, Spontaneous and stimulated emission of radiation, Einstein's coefficients, Population inversion, Various levels of Laser, Ruby Laser, He-Ne Laser, Laser applications.

### **Course Outcomes:**

1. To solve the classical and wave mechanics problems
2. To develop the understanding of laws of thermodynamics and their application in various processes

3. To formulate and solve the engineering problems on Electromagnetism & Electromagnetic Field Theory
4. To aware of limits of classical physics & to apply the ideas in solving the problems in their parent streams

**Reference Books:**

1. Concepts of Modern Physics - AurtherBeiser (Mc-Graw Hill)



## **Program Outcomes (PO's) relevant to the course:**

- PO1 Engineering knowledge:** Apply the knowledge of mathematics, science, engineering fundamentals, and an engineering specialization to the solution of complex engineering problems.
- PO2 Problem analysis:** Identify, formulate, review research literature, and analyze complex engineering problems reaching substantiated conclusions using first principles of mathematics, natural sciences, and engineering sciences.
- PO3 Design/development of solutions:** Design solutions for complex engineering problems and design system components or processes that meet the specified needs with appropriate consideration for the public health and safety, and the cultural, societal, and environmental considerations.
- PO4 Conduct investigations of complex problems:** Use research-based knowledge and research methods including design of experiments, analysis and interpretation of data, and synthesis of the information to provide valid conclusions
- PO5 Modern tool usage:** Create, select, and apply appropriate techniques, resources, and modern engineering and it tools including prediction and modeling to complex engineering activities with an understanding of the limitations.
- PO6 The engineer and society:** Apply reasoning informed by the contextual knowledge to assess societal, health, safety, legal and cultural issues and the consequent responsibilities relevant to the professional engineering practice.
- PO7 Environment and sustainability:** Understand the impact of the professional engineering solutions in societal and environmental contexts, and demonstrate the knowledge of, and need for sustainable development.
- PO8 Ethics:** Apply ethical principles and commit to professional ethics and responsibilities and norms of the engineering practice..
- PO9 Individual and team work:** : Function effectively as an individual, and as a member or leader in diverse teams, and in multidisciplinary settings
- PO10 Communications:** Communicate effectively on complex engineering activities with the engineering community and with society at large, such as, being able to comprehend and write effective reports and design documentation, make effective presentations, and give and receive clear instructions.
- PO11 Project management and finance:** : Demonstrate knowledge and understanding of the engineering and management principles and apply these to one's own work, as a member and leader in a team, to manage projects and in multidisciplinary environments.

**PO12 Life-long learning:** Recognize the need for, and have the preparation and ability to engage in independent and life-long learning in the broadest context of technological change.

**COURSE OUTCOMES (COs): Engineering Physics (KAS-101T/201T),**  
**YEAR OF STUDY: 2020-21**

<b>Course outcomes</b>	Statement (On completion of this course, the student will be able to -)
<b>CO1</b>	Understand the basics of relativistic mechanics.(K2)
<b>CO2</b>	Develop EM-wave equations using Maxwell's equations.(K1)
<b>CO3</b>	Understand the concepts of quantum mechanics.(K2)
<b>CO4</b>	Describe the various phenomena of light and its applications in different fields.(K1)
<b>CO5</b>	Comprehend the concepts and applications of fiber optics and LASER.(K2)

**Mapping of Course Outcomes with Program Outcomes (CO-PO Mapping)**

1. Slight ( low)    2. Moderate ( medium)    3. Substantial (high)

COs/POs	PO1	PO2	PO3	PO4	PO5	PO6	PO7	PO8	PO9	PO10	PO11	PO12
CO1	3	3										3
CO2	3	3				3						3
CO3	3	3										3
CO4	2											3
CO5	3					3						3
<b>KAS-101T/201T</b>	3	3				3						3

### 1.1 Introduction of Newtonian Mechanics

The universe, in which we live, is full of dynamic objects. Nothing is static here Starting from giant stars to tiny electrons, everything is dynamic. This dynamicity of universal objects leads to variety of interactions, events and happenings. The curiosity of human being/scientist to know about these events and laws which governs them. Mechanics is the branch of Physics which is mainly concerned with the study of mobile bodies and their interactions.

A real breakthrough in this direction was made by Newton in 1664 by presenting the law of linear motion of bodies. Over two hundred years, these laws were considered to be perfect and capable of explaining everything of nature.

### 1.2 Frames of Reference

The dynamicity of universal objects leads to variety of interactions between these objects leading to various happenings. These happenings are termed as **events**. The relevant data about an event is recorded by some person or instrument, which is known as **“Observer”**.

The motion of material body can only be described relative to some other object. As such, to locate the position of a particle or event, we need a coordinate system which is at rest with respect to the observer. Such a coordinate system is referred to as frame of reference or observer's frame of reference.

“A reference frame is a space or region in which we are making observation and measuring physical (dynamical) quantities such as velocity and acceleration of an object (event).” or

“A frame of reference is a three dimensional coordinate system relative to which is described the position and motion (velocity and acceleration) of a body (object)”

Fig.1.1 represents a frame of reference (S), an object is situated at point P having co-ordinates  $x, y, z$  and  $t$  i.e.  $P(x, y, z, t)$ , measured by an Observer (O). Where  $t$  is the time of measurement of the co-ordinate of an object. Observers in different frames of reference may describe the same event in Fig 1.1: frame of reference differently.

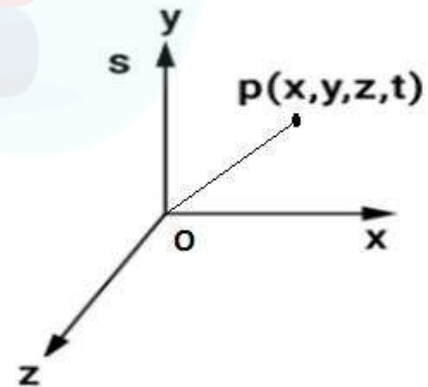

Example- take a point on the rim of a moving wheel of a cycle. For an observer sitting at the center of the wheel, the path of the point will be a circle. However, for an observer standing on the ground the path of the point will appear as a cycloid.

There are two types of frames of reference.

1. Inertial or non-accelerating frames of reference

2. Non-inertial or accelerating frames of reference

The frame of reference in which Newton's laws of motion hold good is treated as **inertial frame of reference**. However, the frame of reference in which Newton's laws of motion not hold good is treated as **non-inertial frame of reference**. Earth is non-inertial frame of reference, because it has acceleration due to spin motion about its axis and orbital motion around the sun.

**1.3 Galilean Transformations**

The Galilean transformations equations are used to transform the coordinates of position and time from one inertial frame to the other. The equations relating the coordinates of a particle in two inertial frames are called as Galilean transformations. Consider the two inertial frames of reference F and F'. Let the frame F' is moving with constant velocity v with reference to frame F. The frames F and F' are shown in Fig.1

Let some event occurs at the point P at any instant of time t. The coordinates of point P with respect to frame F are x, y, z, t and with respect to frame F' are x', y', z', t'. Let at t = t' = 0, the origin O of frame F and O' of frame F' coincides with one another. Also axes x and x' are parallel to v. Let y' and z' are parallel to y and z respectively.

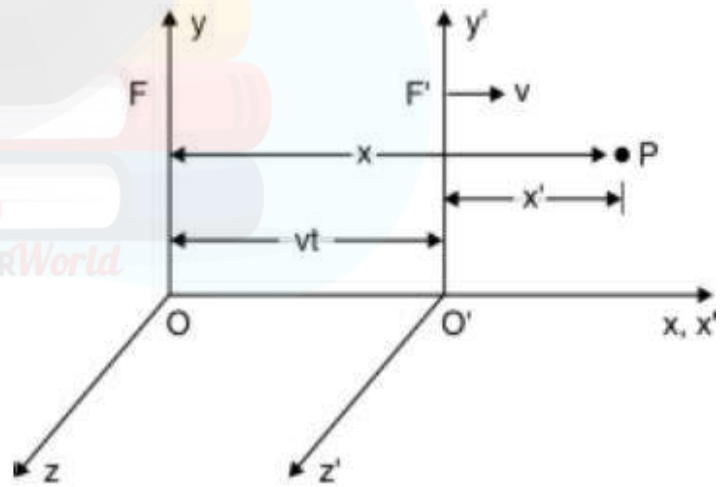

From Fig.

$x = x' + vt$ .....(1)  $x' = x -$

$vt$ .....(2)

As there is no relative motion along y and z axes, we can write  $y' = y$ .....(3),

$z' = z$ .....(4), and  $t' = t$ .....(5)

These equations are called as Galilean transformation equations. The inverse Galilean transformation can be written as,  $x = x' + vt$ ,  $y = y'$ ,  $z = z'$  and  $t = t'$

Hence transformation in position is variant only along the direction of motion of the frame and remaining dimensions (y and z) are unchanged under Galilean Transformation. At that era scientist were assumed time should be absolute.

**b) Transformation in velocities components:**

The conversion of velocity components measured in frame F into their equivalent components in the frame F' can be known by differential Equation (1) with respect to time we get,



$$u'_x = \frac{dx'}{dt} = \frac{d}{dt}(x - vt) = \frac{dx}{dt} - v$$

hence  $u'_x = u_x - v$

Similarly, from Equation (3) and (4) we can write

$$u'_y = u_y \text{ and } u'_z = u_z$$

In vector form,

$$\mathbf{u}' = \mathbf{u} - \mathbf{v}$$

Hence transformation in velocity is variant only along the direction of motion of the frame and remaining dimensions( along y and z) are unchanged under Galilean Transformation.

### c) Transformation in acceleration components:

The acceleration components can be derived by differentiating velocity equations with respect to time,

$$a'_x = \frac{du'_x}{dt} = \frac{d}{dt}(u_x - v)$$

$$a'_x = a_x$$

In vector form  $\mathbf{a}' = \mathbf{a}$

This shows that in all inertial reference frames a body will be observed to have the same acceleration. Hence acceleration are invariant under Galilean Transformation.

### Failures of Galilean transformation:

- ❖ According to Galilean transformations the laws of mechanics are invariant. But under Galilean transformations, the fundamental equations of electricity and magnetism have very different forms.
- ❖ Also if we measure the speed of light  $c$  along x-direction in the frame  $F$  and then in the frame  $F'$  the value comes to be  $c' = c - v_x$ . But according to special theory of relativity the speed of light  $c$  is same in all inertial frames.

### 1.4 Michelson-Morley Experiment

“The objective of Michelson - Morley experiment was to detect the existence of stationary medium ether (stationary frame of reference i.e. ether frame.)”, which was assumed to be required for the propagation of the light in the space.

In order to detect the change in velocity of light due to relative motion between earth and hypothetical medium ether, Michelson and Morley performed an experiment which is discussed below. The experimental arrangement is shown in Fig



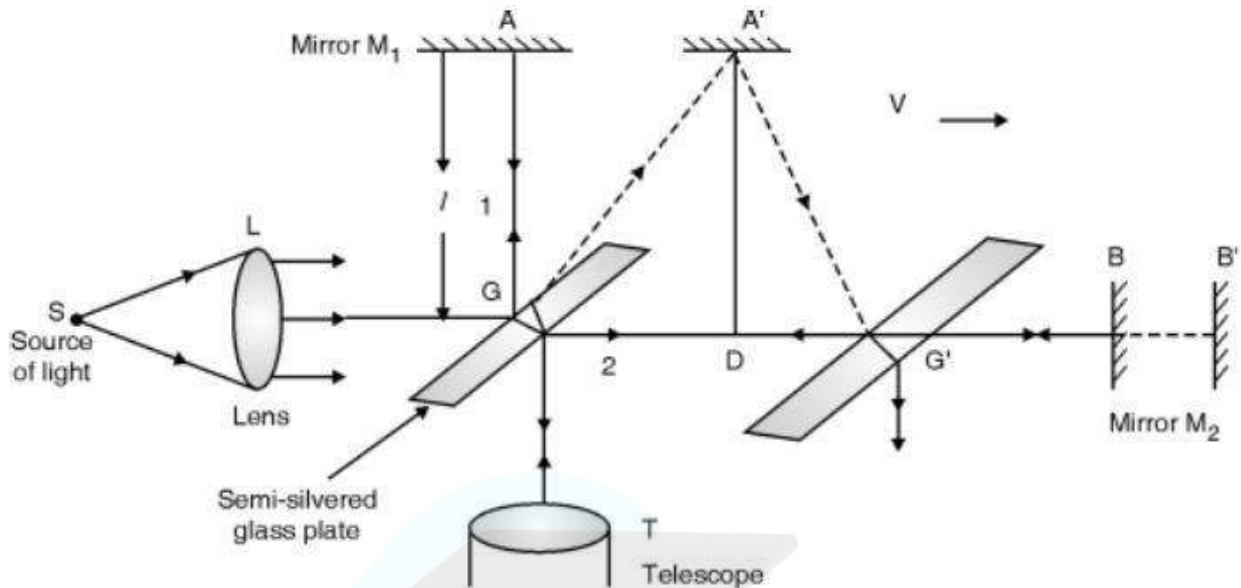

Light from a monochromatic source S, falls on the semi-silvered glass plate G inclined at an angle  $45^\circ$  to the beam. It is divided into two parts by the semi silvered surface, one ray 1 which travels towards mirror  $M_1$  and other is transmitted, ray 2 towards mirror  $M_2$ . These two rays fall normally on mirrors  $M_1$  and  $M_2$  respectively and are reflected back along their original paths and meet at point G and enter in telescope. In telescope interference pattern is obtained.

If the apparatus is at rest in ether, the two reflected rays would take equal time to return the glass plate G. But actually the whole apparatus is moving along with the earth with a velocity say  $v$ . Due to motion of earth the optical path traversed by both the rays are not the same. Thus the time taken by the two rays to travel to the mirrors and back to G will be different in this case.

Let the mirrors  $M_1$  and  $M_2$  are at equal distance  $l$  from the glass plate G. Further let  $c$  and  $v$  be the velocities at light and apparatus or earth respectively. It is clear from Fig. that the reflected ray 1 from glass plate G strikes the mirror  $M_1$  at  $A'$  and not at A due to the motion of the earth.

The total path of the ray from G to  $A'$  and back will be  $GA'G'$ .

∴ From  $\Delta GA'D$   $(GA')^2 = (AA')^2 + (A'D)^2 \dots (1)$  As  $(GD = AA')$

If  $t$  be the time taken by the ray to move from G to  $A'$ , then from Equation (1), we have

$$(c t)^2 = (v t)^2 + l^2$$

Hence  $t = \frac{l}{\sqrt{c^2 - v^2}}$

If  $t_1$  be the time taken by the ray to travel the whole path  $GA'G'$ , then

$$t_1 = 2t = \frac{2l}{\sqrt{c^2 - v^2}} = \frac{2l}{c} \left(1 - \frac{v^2}{c^2}\right)^{-1/2}$$

$$t_1 = \frac{2l}{c} \left(1 + \frac{v^2}{2c^2}\right) \dots\dots\dots(2) \text{ Using Binomial Theorem}$$

Now, in case of transmitted ray 2 which is moving longitudinally towards mirror M<sub>2</sub>. It has a velocity (c – v) relative to the apparatus when it is moving from G to B. During its return journey, its velocity relative to apparatus is (c + v). If t<sub>2</sub> be the total time taken by the longitudinal ray to reach G', then

$$t_2 = \frac{l}{(c-v)} + \frac{l}{(c+v)} \text{ after solving}$$

$$t_2 = \frac{2l}{c} \left(1 + \frac{v^2}{c^2}\right) \dots\dots\dots(3)$$

Thus, the difference in times of travel of longitudinal and transverse journeys is

$$\Delta t = t_2 - t_1 = \frac{2l}{c} \left(1 + \frac{v^2}{c^2}\right) - \frac{2l}{c} \left(1 + \frac{v^2}{2c^2}\right)$$

$$\Delta t = \frac{lv^2}{c^3} \dots\dots\dots(4)$$

The optical path difference between two rays is given as,

$$\text{Optical path difference } (\Delta) = \text{Velocity} \times t = c \times \Delta t$$

$$= c \times \frac{lv^2}{c^3}$$

$$\Delta = \frac{lv^2}{c^2} \dots\dots\dots(5)$$

If λ is the wavelength of light used, then path difference in terms of wavelength is,  $\Delta = \frac{lv^2}{\lambda c^2}$

Michelson-Morley perform the experiment in two steps. First by setting as shown in fig and secondly by turning the apparatus through 90°. Now the path difference is in opposite direction i.e. path difference is  $-\frac{lv^2}{\lambda c^2}$ .

Hence total fringe shift  $\Delta N = \frac{\Delta}{\lambda}$

Michelson and Morley using l=11 m, λ= 5800 x 10<sup>-10</sup> m, v= 3 x 10<sup>4</sup> m/sec and c= 3 x 10<sup>8</sup> m/sec ∴ Change in fringe shift  $\Delta N = \frac{2lv^2}{\lambda c^2}$  substitute all these values

$$\frac{c^2}{\lambda}$$

$$=0.37 \text{ fringe}$$

But the experimental were detecting no fringe shift. So there was some problem in theory calculation and is a negative result. The conclusion drawn from the Michelson-Morley experiment is that, there is no existence of stationary medium ether in space.

### Negative results of Michelson - Morley experiment

1. **Ether drag hypothesis:** In Michelson - Morley experiment it is explained that there is no relative motion between the ether and earth. Whereas the moving earth drags ether along with its motion so the relative velocity of ether and earth will be zero.
2. **Lorentz-Fitzgerald Hypothesis:** Lorentz told that the length of the arm (distance between the pole and the mirror  $M_2$ ) towards the transmitted side should be  $L(\sqrt{1 - v^2/c^2})$  but not  $L$ . If this is taken then theory and experimental will get matched. But this hypothesis is discarded as there was no proof for this.
3. **Constancy of Velocity of light:** In Michelson - Morley experiment the null shift in fringes was observed. According to Einstein the velocity of light is constant it is independent of frame of reference, source and observer.

### Einstein special theory of Relativity (STR)

Einstein gave his special theory of relativity (STR) on the basis of M-M experiment

#### Einstein's First Postulate of theory of relativity:

All the laws of physics are same (or have the same form) in all the inertial frames of reference moving with uniform velocity with respect to each other. (This postulate is also called the **law of equivalence**).

#### Einstein's second Postulate of theory of relativity:

The speed of light is constant in free space or in vacuum in all the inertial frames of reference moving with uniform velocity with respect to each other. (This postulate is also called the **law of constancy**).

### 1.5 Lorentz Transformation Equations

Consider the two observers  $O$  and  $O'$  at the origin of the inertial frame of reference  $F$  and  $F'$  respectively as shown in Fig. Let at time  $t = t' = 0$ , the two coordinate systems coincide initially. Let a pulse of light is flashed at time  $t = 0$  from the origin which spreads out in the space and at the same time the frame  $F'$  starts moving with constant velocity  $v$  along positive  $X$ -direction relative to the frame  $F$ . This pulse of light reaches at point  $P$ , whose coordinates of position and time are

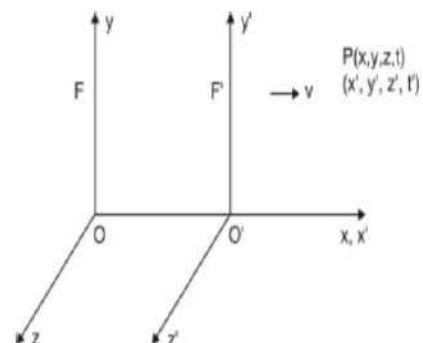

**Module-2-Electromagnetic Field Theory**

**CO2**

(x, y, z, t) and (x',y', z', t') measured by the observer O and O' respectively. Therefore the transformation equations of x and x' can be given as,

$$x'=k(x - v t) \dots\dots\dots(1)$$

Where k is the proportionality constant and is independent of x and t.  
The inverse relation can be given as,

$$x=k(x' + v t') \dots\dots\dots (2)$$

As t and t' are not equal, substitute the value of x' from Equation (1) in Equation (2)

$$x=k[k(x - vt) + vt'] \quad \text{or} \quad \frac{x}{k}=(kx - kv t + vt')$$

$$t'=\frac{x}{kv} - \frac{kx}{v} + kt \quad \text{or} \quad t'=kt - \frac{kx}{v} \left(1 - \frac{1}{k^2}\right) \dots\dots\dots(3)$$

According to second postulate of special theory of relativity the speed of light c remains constant. Therefore the velocity of pulse of light which spreads out from the common origin observed by observer O and O' should be same.

$$\therefore x=ct \text{ and } x' = ct' \dots\dots\dots(4)$$

Substitute the values of x and x' from Equation (4) in Equation (1) and (2) we get

$$ct'=k(x - v t) = k(ct - v t) \quad \text{or} \quad ct'=kt(c - v) \dots\dots\dots(5) \text{ and}$$

similarly  $ct=k t'(c + v) \dots\dots\dots(6)$  Multiplying

Equation (5) and (6) we get,  $c^2 t t'=k^2 t t'(c^2 - v^2)$  hence

after solving  $k = \frac{c}{\sqrt{c^2 - v^2}} \dots\dots\dots(7)$

Hence equation (7) substitute in equation (1), then Lorentz transformation in position will be

$$x' = \frac{x - vt}{\sqrt{1 - \frac{v^2}{c^2}}}, \quad y=y', \quad z'=z$$

Calculation of Time: equation (7) substitute in equation (3),

$$t' = kt - \frac{kx}{v} \left(1 - \frac{1}{k^2}\right)$$

From equation ( 7),  $\frac{1}{k^2} = 1 - \frac{v^2}{c^2}$

or,  $\frac{v^2}{c^2} = 1 - \frac{1}{k^2}$

then above equation becomes

$$t' = kt - \frac{kxv^2}{c^2} = kt - \frac{kxv}{c^2}$$

or,  $t' = k \left( t - \frac{xv}{c^2} \right)$

$$t' = \frac{t - \frac{xv}{c^2}}{\sqrt{1 - \frac{v^2}{c^2}}}$$

Therefore

Hence the Lorentz transformation equations becomes,

$$x' = \frac{x - vt}{\sqrt{1 - \frac{v^2}{c^2}}}, \quad y' = y, \quad z' = z \text{ and } t' = \frac{t - \frac{xv}{c^2}}{\sqrt{1 - \frac{v^2}{c^2}}}$$

Under the condition  $v \ll c$  Lorentz transformation equation can be converted in to Galilean Transformation

$$x' = x - vt, \quad y' = y, \quad z' = z \text{ and } t' = t$$

### 1.6 Applications of Lorentz Transformation

#### 1.6.1 Length contraction

Consider a rod at rest in a moving frame of reference F' moving along x-direction with constant velocity v, relative to the fixed frame of reference F as shown in Fig.

The observer in the frame F' measures the length of rod AB at any instant of time t. This length  $L_0$  measured in the system in which the rod is at rest is called proper length, therefore  $L_0$  is given as,

$$L_0 = x_2' - x_1' \dots\dots\dots(1)$$

Where  $x_1'$  and  $x_2'$  are the coordinates of the two ends of the rod at any instant. At the same time, the length of the rod is measured by an observer O in his frame say L, then

$$L = x_2 - x_1 \dots\dots\dots(2)$$

Where  $x_1$  and  $x_2$  are the coordinates of the rod AB respectively with respect to the frame F. According to Lorentz transformation equation

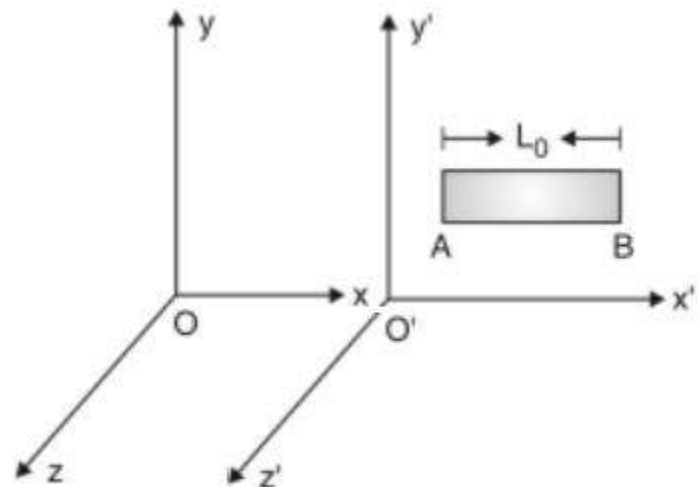

$$x_1' = \frac{x_1 - vt}{\sqrt{1 - \frac{v^2}{c^2}}} \quad \text{and} \quad x_2' = \frac{x_2 - vt}{\sqrt{1 - \frac{v^2}{c^2}}}$$

Hence 
$$x_2' - x_1' = \frac{x_2 - x_1}{\sqrt{1 - \frac{v^2}{c^2}}}$$

By using Equations (1) and (2) we can write

$$L = L_0 \sqrt{1 - \frac{v^2}{c^2}} \quad \dots\dots\dots(3)$$

From this equation  $L \ll L_0$ . Thus the length of the rod is contracted by a factor  $\sqrt{1 - \frac{v^2}{c^2}}$  as measured by observer in stationary frame F.

**Special Case:**

If  $v \ll c$ , then  $v^2/c^2$  will be negligible in  $L_0 \sqrt{1 - \frac{v^2}{c^2}}$  and it can be neglected

Then equation (3) becomes  $L = L_0$ .

Percentage of length contraction =  $\frac{L_0 - L}{L_0} \times 100$

**1.6.2 Time dilation**

Let there are two inertial frames of references F and F'. F is the stationary frame of reference and F' is the moving frame of reference. At time  $t=t'=0$  that is in the start, they are at the same position that is Observers O and O' coincides. After that F' frame starts moving with a uniform velocity v along x axis.

Let a clock is placed in the frame F'. The time coordinate of the initial time of the clock will be  $t_1$  according to the observer in S and the time coordinate of the final tick (time) will be will be  $t_2$  according to same observer.

The time coordinate of the initial time of the clock will be  $t'_1$  according to the observer in F' and the time coordinate of the final tick (time) will be will be  $t'_2$  according to same observer.

Therefore the time of the object as seen by observer O' in F' at the position x' will be

$$t_0 = t'_2 - t'_1 \dots\dots\dots(1)$$

The time t' is called the proper time of the event. The apparent or dilated time of the same event from frame S at the same position x will be

$$t = t_2 - t_1 \dots\dots\dots(2)$$

Now use Lorentz inverse transformation equations for, that is

$$t_1 = \frac{t'_1 + \frac{vx'_1}{c^2}}{\sqrt{1 - \frac{v^2}{c^2}}} \dots\dots\dots (3)$$

$$t_2 = \frac{t'_2 + \frac{vx'_2}{c^2}}{\sqrt{1 - \frac{v^2}{c^2}}} \dots\dots\dots (4)$$

By putting equations (3) and (4) in equation (2) and solving, we get

$$t = \frac{t'_2 - t'_1}{\sqrt{1 - \frac{v^2}{c^2}}}$$

Substitute equation (1) in above equation,

$$t = \frac{t_0}{\sqrt{1 - \frac{v^2}{c^2}}}$$

This is the relation of the time dilation.

**Special Case:**

If  $v \ll c$ , then  $v^2/c^2$  will be negligible in  $\sqrt{1 - \frac{v^2}{c^2}}$  and it can be neglected

Then  $t = t_0$

**Experimental evidence:** The time dilation is real effect can be verified by the following experiment. In 1971 NASA conducted one experiment in which J.C. Hafele, as astronomer and R.F. Keating, a physicist circled the earth twice in a jet plane, once from east to west for two days and then from west to east for two days carrying two cesium-beam atomic clocks capable of measuring time to a nanosecond. After the trip the clocks were compared with identical clocks. The clocks on the plane lost  $59 \pm 10$  ns during their

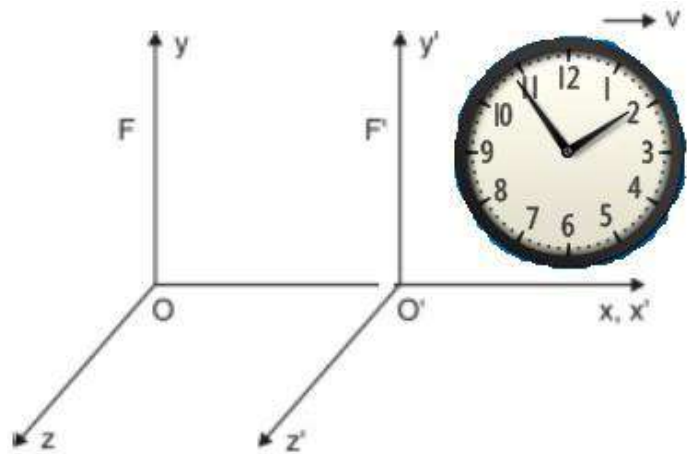



eastward trip and gained  $273 \pm 7$  ns during the westward trip. This results shows that time dilation is real effect.

### 1.6.3 Relativistic Addition of Velocities

One of the consequences of the Lorentz transformation equations is the counter-intuitive “velocity addition theorem”. Consider an inertial frame  $S'$  moving with uniform velocity  $v$  relative to stationary observer  $S$  along the positive direction of X- axis. Suppose a particle is also moving along the positive direction of X-axis. If the particle moves through a distance  $dx$  in time interval  $dt$  in frame  $S$ , then velocity of the particle as measured by an observer in this frame is given by

$$u = \frac{dx}{dt} \quad (1)$$

To an observer in  $S'$  frame, let the velocity be (by definition)

$$u' = \frac{dx'}{dt'} \quad (2)$$

Now, we have the Lorentz transformation equations:

$$x' = \frac{x-vt}{\sqrt{1-\frac{v^2}{c^2}}} \quad \text{and} \quad t' = \frac{t-\frac{vx}{c^2}}{\sqrt{1-\frac{v^2}{c^2}}} \quad (3)$$

Taking differentials of above equations, we get

$$dx' = \frac{dx-vdt}{\sqrt{1-v^2/c^2}} \quad \text{and} \quad dt' = \frac{dt-vdx/c^2}{\sqrt{1-v^2/c^2}} \quad (4) \text{ Using}$$

eq (4) in eq.(2), we get

$$u' = \frac{dx-vdt}{dt-vdx/c^2} = \frac{\left(\frac{dx}{dt}\right)-v}{(1-vdx/c^2 dt)} \quad (5)$$

Or,

$$u' = \frac{u-v}{(1-uv/c^2)} \quad (6)$$

This is the the relativistic velocity addition formula. If the speeds  $u$  and  $v$  are small compared to the speed of light, above formula reduces to Newtonian velocity addition formula

$$u = u - v$$

Inverse of the formula (6) enables us to find velocity of a particle in  $S$  frame if it is given in  $S'$  frame:

$$u = \frac{u' + v}{1+u'v/c^2} \quad (6)$$

### 1.7 Variation of Mass with Velocity

In Newtonian physics mass of an object used to be an absolute entity, same in all frames. One of the major unusual consequences of relativity was relativity of mass. In the framework of relativity, it can be shown that mass of an object increases with its velocity. We have the following equation expressing the variation of mass with velocity:

$$m = \frac{m_0}{\sqrt{(1-v^2/c^2)}} \quad (1)$$

Where,  $m_0$  is the mass of the object at rest, known as *rest mass* and  $v$  is its velocity relative to observer, As it is clear from above equation, if  $v \ll c$ ,  $m_0 \cong m$ , in agreement with common experience.

#### Derivation:

We use relativistic law of momentum conservation to arrive at eq (1). Consider two inertial frames S and S', S' moving with respect to S with velocity  $v$  along positive X-axis. Let two masses  $m_1$  and  $m_2$  are moving with velocities  $u'$  and  $-u'$  with respect to moving frame S'.

Now, let us analyse the collision between two bodies with respect to frame S. If  $u_1$  and  $u_2$  are velocities of two masses with respect to frame S, then from velocity addition theorem,

$$u_1 = \frac{u+v}{1+u'v/c^2} \quad \text{and} \quad u_2 = \frac{-u'+v}{1-u'v/c^2} \quad (2) \text{ At the } \quad \text{time of}$$

collision two masses are momentarily at rest relative to frame S', but as seen from frame S they are still moving with velocity  $v$ . Since we assume momentum to be conserved even in relativity theory, as seen from S frame,

Momentum before collision = momentum after collision

$$m_1 u_1 + m_2 u_2 = (m_1 + m_2)v \quad (3)$$

Substituting the values of  $u_1$  and  $u_2$  from equation (2), eq.(3) becomes

$$m_1 \left( \frac{u+v}{1+u'v/c^2} \right) + m_2 \left( \frac{-u'+v}{1-u'v/c^2} \right) = (m_1 + m_2)v$$

Rearranging the terms,

$$m_1 \left( \frac{u+v}{1+u'v/c^2} - v \right) = m_2 \left( v - \frac{-u'+v}{1-u'v/c^2} \right)$$

2)  
(-u v

$$m_1 \left( \frac{u'+v-v-(u'v^2/c^2)}{1+u'v/c^2} \right) = m_2 \left( \frac{v-\frac{u'^2}{c^2}+u'-v}{1-u'v/c^2} \right)$$

2) (u v)

Or,  $m_1 \left( \frac{u'-(u'v^2/c^2)}{1+u'v/c^2} \right) = m_2 \left( \frac{u'-\frac{u'^2}{c^2}}{1-u'v/c^2} \right)$

$$\frac{m_1}{m_2} = \frac{1+u'v/c^2}{1-u'v/c^2} \quad (4) \text{ Now}$$

, using set of equations (2), we can find RHS of equation to be equal to

$$\frac{1+u'v/c^2}{1-u'v/c^2} = \sqrt{\frac{1-\frac{u_2^2}{c^2}}{1-\frac{u_1^2}{c^2}}} = \frac{m_1}{m_2}$$

If  $u_2 = 0$ , i.e.  $m_2 (= m_0, \text{say})$  is at rest with respect to S frame, above equation reduces to

$$m_1 = \frac{m_0}{\sqrt{1-\frac{u_1^2}{c^2}}}$$

We could have chosen two masses to be identical. In that case  $m_0$  will also be the rest mass of  $m_1$ . So we can apply above formula to a single with rest mass  $m_0$  and moving mass  $m$ , related by

$$m = \frac{m_0}{\sqrt{1-\frac{u^2}{c^2}}}$$

This shows that mass of a body increases with its velocity.

## 1.8 Mass- Energy Equivalence

In Newtonian Physics, mass and energy are assumed to be quite different entities. There is no mechanism in Newtonian set up, how mass and energy can be converted into each other. Like many other, it is one of unusual consequences of special relativity that mass and energy are inter-convertible into each other and hence are equivalent.

### Einstein's Mass- energy relation ( $E = mc^2$ ) (Derivation)

Consider a particle of mass  $m$  acted upon by a force  $F$  in the same direction as its velocity  $v$ . If  $F$  displaces the particle through distance  $ds$ , then work done  $dW$  is stored as kinetic energy of the particle  $dK$ , therefore

$$dW = dK = F \cdot ds \quad (1)$$

But from Newton's law,

**Module-2-Electromagnetic Field Theory****CO2**

$$F = \frac{dp}{dt} = \frac{d}{dt}(mv) = m \frac{dv}{dt} + v \frac{dm}{dt} \quad (2)$$

Using (2) in (1)

$$dK = m \frac{dv}{dt} ds + v \frac{dm}{dt} ds = m \frac{ds}{dt} dv + v \frac{ds}{dt} dm$$

Or, 
$$dK = mv dv + v^2 dm \quad (3)$$

Now we have,

$$m = \frac{m_0}{\sqrt{1 - \frac{v^2}{c^2}}} = m_0 \left(1 - \frac{v^2}{c^2}\right)^{-1/2} \quad (4)$$

Taking the differential ,

$$dm = m_0 \left(-\frac{1}{2}\right) \left(1 - \frac{v^2}{c^2}\right)^{-3/2} \left(\frac{-2v dv}{c^2}\right) = \frac{m_0 v dv}{c^2 \left(1 - \frac{v^2}{c^2}\right)^{3/2}}$$

But  $m_0 = m \left(1 - \frac{v^2}{c^2}\right)^{1/2}$

$$dm = \frac{m \left(1 - \frac{v^2}{c^2}\right)^{1/2} v dv}{c^2 \left(1 - \frac{v^2}{c^2}\right)^{3/2}}$$

Or 
$$dm = \frac{m v dv}{(c^2 - v^2)} \quad \text{or,} \quad m v dv = (c^2 - v^2) dm$$

(5)

Using eq (5) in eq (3)

$$dK = (c^2 - v^2) dm + v^2 dm = c^2 dm$$

Let the change in kinetic energy of the particle be  $K$ , as its mass changes from rest mass  $m_0$  to to effective mass  $m$ , then

$$K = \int_0^K dK = \int_{m_0}^m c^2 dm = c^2(m - m_0) = c^2 \left( \frac{m_0}{\sqrt{1 - \frac{v^2}{c^2}}} - m_0 \right)$$

This is the relativistic expression for kinetic energy of a particle. It says that kinetic energy of a particle is due to the increase in mass of the particle on account of its relative motion and is equal to the product of the gain in mass and square of the velocity of light.  $m_0 c^2$  can be regarded as the rest energy of the particle of rest mass  $m_0$ . The total energy  $E$  of a moving particle is the sum of kinetic energy and its rest mass energy.

$$E = m_0 c^2 + (m - m_0) c^2 = m c^2$$

Or,

$$E = mc^2$$

This is the celebrated mass- energy equivalence relation. This equation is so famous that even common men identify Einstein with it.

**Significance:** This equation represents that energy can neither be created nor be destroyed, but it can change its form.

### Evidence show its validity:

First verification of the  $E = mc^2$  was made by Cock-croft and Walton

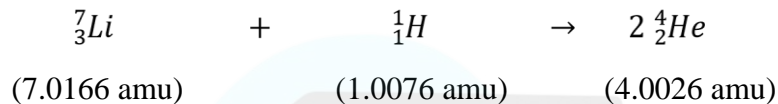

Mass defect =  $(7.0166 \text{ amu} + 1.0076 \text{ amu}) - 2 \times (4.0028 \text{ amu})$

$$= 0.0186 \text{ amu}$$

$$= 0.0186 \times 1.66 \times 10^{-27} \text{ kg}$$

$$E = mc^2 = 0.0186 \times 1.66 \times 10^{-27} \times (3 \times 10^8)^2$$

$$E = 0.278 \times 10^{-11} \text{ joule}$$

$$E = \frac{(0.278 \times 10^{-11})}{(1.66 \times 10^{-19})} \text{ eV}$$

$$E = 17.36 \text{ MeV}$$

( a huge amount of energy release)

## 1.9 Relation between Energy and Momentum

### a) Relation between total Energy and Momentum

Since we know that

$$E = mc^2 = \frac{m_0 c^2}{\sqrt{1 - \frac{v^2}{c^2}}}$$

Squaring both side

$$E^2 \left(1 - \frac{v^2}{c^2}\right) = m_0^2 c^4$$

$$E^2 c^2 - E^2 v^2 = m_0^2 c^6$$

Science  $p = mv$ ,  $v = \frac{p}{m}$  substitute in above equation

$$E^2 c^2 - E^2 \left(\frac{p}{m}\right)^2 = m_0^2 c^6, \text{ after solving}$$

$$E^2 = p^2 c^2 + m_0^2 c^4$$

This is the relation between relativistic total energy and momentum of the particle.

### b) Relation between Kinetic Energy and Momentum

Science we know that  $E^2 = p^2 c^2 + m_0^2 c^4$  -----(1)

Also we know that  $E = E_0 + E_K$

$$E = m_0 c^2 + E_K$$

Squaring both side

$$E^2 = (m_0 c^2 + E_K)^2$$
 -----(2)

From equation (1) and (2), we get

$$p^2 c^2 + m_0^2 c^4 = (m_0 c^2 + E_K)^2$$

$$p^2 c^2 + m_0^2 c^4 = m_0^2 c^4 + E_K^2 + 2m_0 c^2 E_K$$

After solving

$$p = \sqrt{\frac{E_K^2}{c^2} + 2m_0 E_K}$$

Where  $E_K =$  kinetic energy

### 1.10 Mass-less Particle /Zero Rest Mass Particles:

A particle which has zero rest mass ( $m_0$ ) is called massless particle

We have the energy-momentum relation,

$$E = \sqrt{m_0^2 c^4 + (p^2 c^2)} \quad (1)$$

**Module-2-Electromagnetic Field Theory****CO2**

For a massless particle,  $m_0 = 0$

Therefore,  $E = pc$  or  $p = E/c$  (2)

But  $p = mv$ , therefore

$$\frac{Ev}{c^2} = \frac{E}{c}$$

Which implies  $v = c$

This says that a massless particles always move with the speed of light. Energy and momentum of a massless particle is given by equation (2). Massless particles can exist only as long as the move at the speed of light. Examples are photon, neutrinos and theoretically predicted gravitons.

**Numerical Problems**

**Question 1:** Show that the distance between any two points in two inertial frame is invariant under Galilean transformation.

**Answer:** Consider two frame of reference S and S', frame S' moving with constant velocity v, relative to frame S in positive X-direction .

Point A and B placed in frame S and their co-ordinate relative O are  $(x_1, y_1, z_1)$  and  $(x_2, y_2, z_2)$ .

After time t the coordinate of A and B relative to observer O' from frame S' will be  $(x'_1, y'_1, z'_1)$  and  $(x'_2, y'_2, z'_2)$

Using Galilean Transformation

$$x'_1 = x_1 - vt \quad y'_1 = y_1 \quad \text{and} \quad z'_1 = z_1$$

$$x'_2 = x_2 - vt \quad y'_2 = y_2 \quad \text{and} \quad z'_2 = z_2$$

Now distance between two points from

frame S' will be

$$= \sqrt{(x'_2 - x'_1)^2 + (y'_2 - y'_1)^2 + (z'_2 - z'_1)^2}$$

Substitute all values then

$$= \sqrt{(x_2 - vt - x_1 + vt)^2 + (y_2 - y_1)^2 + (z_2 - z_1)^2}$$

After simplification



$$= \sqrt{(x_2 - x_1)^2 + (y_2 - y_1)^2 + (z_2 - z_1)^2} \quad \text{i.e}$$

$$S' = S$$

This show that, distance between two points is invariant under Galilean Transformation

**Question 2:** Show that the relativistic form of Newton's second law, when  $\vec{F}$  is parallel to  $\vec{v}$  is

$$\vec{F} = m_0 \frac{dv}{dt} \left(1 - \frac{v^2}{c^2}\right)^{-3/2}$$

**Answer:** Science we know that

$$\vec{F} = \frac{d\vec{p}}{dt} = \frac{dmv}{dt}$$

$$\vec{F} = \frac{d}{dt} \left( \frac{m_0 v}{\sqrt{1 - \frac{v^2}{c^2}}} \right) = \left[ m_0 \left( v \left(1 - \frac{v^2}{c^2}\right)^{-1/2} \right) \right]$$

$$= m_0 \left[ \frac{dv}{dt} \left(1 - \frac{v^2}{c^2}\right)^{-1/2} + \left(-\frac{1}{2}\right) \left(1 - \frac{v^2}{c^2}\right)^{-3/2} \left(0 - \frac{2vdv}{c^2 dt}\right) \right]$$

$$= m_0 \frac{dv}{dt} \left[ \left(1 - \frac{v^2}{c^2}\right)^{-1/2} + \frac{v^2}{c^2} \left(1 - \frac{v^2}{c^2}\right)^{-3/2} \right]$$

$$\vec{F} = m_0 \frac{dv}{dt} \left(1 - \frac{v^2}{c^2}\right)^{-3/2} \left[ 1 + \frac{v^2}{c^2} - \frac{v^2}{c^2} \right]$$

$$-3/2$$

$$\vec{F} = m_0 \frac{dv}{dt} \left(1 - \frac{v^2}{c^2}\right)^{-3/2}, \text{ it is relativistic Newton's second law.}$$

If  $v \ll c$ , then

$$\vec{F} = m_0 \frac{dv}{dt}, \text{ hence } \vec{F} = m_0 \vec{a} \quad (\text{because at } \ll c, m \approx m_0)$$

So it can also be written as  $\vec{F} = m \vec{a}$

Module-2-Electromagnetic Field TheoryCO2

**Question 3:** A particle of rest mass  $m_0$  moves with speed  $\frac{c}{\sqrt{2}}$ . Calculate its mass, momentum, total energy and kinetic energy.

**Answer:** Science we know that

$$m = \frac{m_0}{\sqrt{1-\frac{v^2}{c^2}}} = \frac{m_0}{\sqrt{1-\frac{c^2}{2c^2}}} = \sqrt{2} m_0 = 1.41m_0$$

The momentum of the particle is given by

$$p = mv = 1.41m_0 \times \frac{c}{\sqrt{2}} = m_0 c$$

Total energy of the particle

$$E = mc^2 = 1.41m_0 \times c^2 = 1.41m_0c^2$$

Kinetic energy

$$EK = E - m_0c^2 = 1.41m_0c^2 - m_0c^2 = 0.41m_0c^2$$

**Question 4:** A man weight 50 kg on the earth, when he is in a rocket ship in flight his mass is 50.5 kg as measured by an observer on earth. What is the speed of rocket.

**Answer:** Given that

$$m_0 = 50 \text{ kg}, m = 50.5 \text{ kg and } c = 3 \times 10^8 \text{ m/s}$$

$$m = \frac{m_0}{\sqrt{1-\frac{v^2}{c^2}}} \quad \text{substitute all values and after solving}$$

$$v = 4.23 \times 10^7 \text{ m/s}$$

**Question 5 :** Compute the mass  $m$  and speed  $v$  of an electron having kinetic energy 1.5 MeV. Given rest mass of electron  $m_0 = 9.1 \times 10^{-31} \text{ kg}$ ,  $c = 3 \times 10^8 \text{ m/s}$ .

**Answer:** Given that

$$EK = 1.5 \text{ MeV} = 1.5 \times 10^6 \times 1.6 \times 10^{-19} \text{ joule}, m_0 = 9.1 \times 10^{-31} \text{ kg}$$

$$\text{and } c = 3 \times 10^8 \text{ m/s}$$

$$\text{Kinetic energy}(E_k) = (m - m_0)c^2$$

$$\text{Kinetic energy}(E_k) = (m - m_0)c^2$$

$$m - m_0 = \frac{E_k}{c^2} \quad \text{hence} \quad m = \frac{E_k}{c^2} + m_0, \text{ substitute all values and after solving}$$

$$m = 3.58 \times 10^{-30} \text{ kg}$$

$$\text{Using the relation } m = \frac{m_0}{\sqrt{\left(1 - \frac{v^2}{c^2}\right)}} \text{ where } m = 3.58 \times 10^{-30} \text{ kg and } m_0 = 9.1 \times 10^{-31} \text{ kg}$$

$$\text{Then after solving } v = c = 2.9 \times 10^8 \text{ m/s}$$

**Question 6:** . Calculate the amount of work to be done to increase the speed of an electron from 0.6c to 0.8c. Given that rest mass energy of electron ( $E_0$ ) = 0.50 MeV **Answer:**

$$E_k = (m - m_0)c^2 = \left( \frac{1}{\sqrt{\left(1 - \frac{v^2}{c^2}\right)}} - 1 \right) m_0 c^2$$

Kinetic energy(

$$\text{Where, } E_0 = m_0 c^2 = 0.50 \text{ MeV}$$

For speed 0.6c,

$$E_{k1} = \left( \frac{1}{\sqrt{\left(1 - \frac{(0.6c)^2}{c^2}\right)}} - 1 \right) \times 0.50 \text{ MeV}$$

$$= 1.25 \text{ MeV}$$

For speed 0.8c,

$$E_{k2} = \left( \frac{1}{\sqrt{\left(1 - \frac{(0.8c)^2}{c^2}\right)}} - 1 \right) \times 0.50 \text{ MeV}$$

$$= 3.35 \text{ MeV}$$

Hence, The amount of work to be done (electron increase the speed 0.6c to 0.8c) =  $E_{k2} - E_{k1}$

$$= 2.1 \text{ MeV}$$

### 2.1 Continuity equation for current density

Statement: Equation of continuity represents the law of conservation of charge. The charge flowing out through a closed surface from some volume is equal to the rate of decrease of charge within the volume:

$$I = - \frac{dq}{dt} \quad \dots \quad (1)$$

Where,  $I$  is current flowing out through the surface of a volume and  $-\frac{dq}{dt}$  is the rate of decrease of charge within the volume.

Again we know  $I = \oiint \mathbf{J} \cdot d\mathbf{s}$  and  $q = \iiint \rho dv$

where,  $\mathbf{J}$  is the Conduction current density and  $\rho$  is the volume charge density.

Substituting the expression of  $I$  and  $q$  in equation (1),

$$\oiint \mathbf{J} \cdot d\mathbf{s} = - \iiint \frac{\partial \rho}{\partial t} dv \quad \dots \quad (2)$$

Now, applying Gauss's Divergence Theorem to L.H.S. of above equation

$$\iiint \nabla \cdot \mathbf{J} dv = - \iiint \frac{\partial \rho}{\partial t} dv$$

As the two volume integrals are equal, so their integrands are also equal

Thus, 
$$\nabla \cdot \mathbf{J} = - \frac{\partial \rho}{\partial t}$$

This is continuity equation for time varying fields.

**Equation of Continuity for Steady Currents:** As  $\rho$  does not vary with time for steady currents that is

$$\frac{\partial \rho}{\partial t} = 0$$

$$\text{So, } \nabla \cdot \mathbf{J} = 0$$

This is the continuity equation for steady currents.

## 2.2 Differential form of Maxwell's equations

### 2.2.1 First equation (Gauss Law of Electrostatic)

Gauss law of electrostatic states that the total electric flux  $\Phi_E$  coming out from a closed surface is equal to

$1/\epsilon_0$  times the net charge enclosed by the surface i.e.,  $\oiint \mathbf{E} \cdot d\mathbf{s} = q/\epsilon_0$

$$\oiint \mathbf{D} \cdot d\mathbf{s} = \iiint \rho dv \quad \dots (1)$$

Applying Gauss's Divergence theorem to change L.H.S. of equation (1)  $\oiint \mathbf{D} \cdot d\mathbf{s} = \int_V (\nabla \cdot \mathbf{D}) dv$

Using this equation in equation (1), we will get

$$\iiint (\nabla \cdot \mathbf{D}) dv = \iiint \rho dv$$

As two volume integrals are equal, so their integrands are also equal.

$$\text{Thus, } \nabla \cdot \mathbf{D} = \rho \quad \dots (2)$$

The above equation is the **Differential form of Maxwell's first equation.**

### 2.2.2 Second equation(Gauss Law of Magnetostatic)

Gauss law of magnetostatic states that the total magnetic flux  $\phi_m$  coming out through surface of a volume is always equal to zero.

$$\phi_m = \oiint \mathbf{B} \cdot d\mathbf{s} = 0 \quad \dots(3)$$

Applying Gauss's Divergence theorem  $\oiint \mathbf{B} \cdot d\mathbf{s} = \iiint (\nabla \cdot \mathbf{B}) dv$

Putting this in equation (3)  $\iiint (\nabla \cdot \mathbf{B}) dv = 0$

$$\text{Thus, } \nabla \cdot \mathbf{B} = 0 \quad \dots(4)$$

This equation (4) is **differential form of Maxwell's second equation.**

### 2.2.3 Third Equation(Faraday's Law of Electromagnetic Induction)

1. It states that, if there is a change of magnetic flux linked with a circuit then electromotive force (emf) is induced in the circuit. This induced emf lasts as long as the change in magnetic flux continues.
2. The magnitude of induced emf is equal to the rate of change of magnetic flux linked with the circuit.

$$\text{Therefore, induced emf} = \frac{d\phi_m}{dt} \quad \dots(5)$$

$$\text{Where, } \phi_m = \iint \mathbf{B} \cdot d\mathbf{s} \quad \dots(6)$$

Here negative sign indicates the induced emf set up a current in such a direction that the magnetic effect produced by it opposes the cause producing it.

Again we know emf is the closed line integral of the non-conservative electric field generated by the battery.

$$\text{That is } \text{emf} = \oint \mathbf{E} \cdot d\mathbf{l} \quad \dots(7)$$

Putting equations (6) and (7), in equation (5) we get

$$\oint \mathbf{E} \cdot d\mathbf{l} = - \iint \frac{\partial \mathbf{B}}{\partial t} \cdot d\mathbf{s} \quad \dots(8)$$

Using Stoke's theorem to the L.H.S. of equations (8)  $\oint \mathbf{E} \cdot d\mathbf{l} = \iint (\nabla \times \mathbf{E}) \cdot d\mathbf{s}$

Substituting above equation in equation (8), we get

$$\iint (\nabla \times \mathbf{E}) \cdot d\mathbf{s} = - \iint \frac{\partial \mathbf{B}}{\partial t} \cdot d\mathbf{s}$$

Two surface integral are equal only when their integrands are equal.

Thus  $\nabla \times \mathbf{E} = - \frac{\partial \mathbf{B}}{\partial t} \quad \dots(9)$

This is the differential form of Maxwell's 3<sup>rd</sup> equation.

### 2.2.4 Forth Equation (Modified Ampere's Circuital Law)

To come to the Maxwell's 4<sup>th</sup> equation, let us first discuss Ampere's circuital law.

**Ampere's circuital law:** This law states that the line integral of the magnetic field  $\mathbf{H}$  around any closed path or circuit is equal to the current enclosed by that path. That is  $\oint \mathbf{H} \cdot d\mathbf{l} = I$

If  $\mathbf{J}$  is the current density, then  $I = \iint \mathbf{J} \cdot d\mathbf{s}$

This implies that  $\oint \mathbf{H} \cdot d\mathbf{l} = \iint \mathbf{J} \cdot d\mathbf{s} \quad \dots(10)$

Applying Stoke's theorem to L.H.S. of above equation  $\oint \mathbf{H} \cdot d\mathbf{l} = \iint (\nabla \times \mathbf{H}) \cdot d\mathbf{s}$

Substituting above equation in equation (10), we will get  $\iint (\nabla \times \mathbf{H}) \cdot d\mathbf{s} = \iint \mathbf{J} \cdot d\mathbf{s}$

Two surface integrals are equal only if their integrands are equal

Thus,  $\nabla \times \mathbf{H} = \mathbf{J} \quad \dots(11)$

**Module-2-Electromagnetic Field Theory****CO2**

This is the **differential form of Ampere's circuital Law for steady currents.**

Now, taking divergence on both side of equation (10)  $\nabla \cdot (\nabla \times \mathbf{H}) = \nabla \cdot \mathbf{J}$

As divergence of the curl of a vector is always zero, therefore  $\nabla \cdot (\nabla \times \mathbf{H}) = 0$

It means  $\nabla \cdot \mathbf{J} = 0$

Now, **this is continuity equation for steady current** but not for time varying fields, **as equation of continuity for time varying fields is**  $\nabla \cdot \mathbf{J} = -\frac{\partial \rho}{\partial t}$

So, Ampere's circuital law is incomplete, valid only for steady state current. This is the reason that led Maxwell to modify Ampere's circuital law.

**Modification of Ampere's circuital law:** Maxwell modified Ampere's law by giving the concept of displacement current and displacement current density for time varying fields.

He considered that equation (10) for time varying fields can be written as  $\nabla \times \mathbf{H} = \mathbf{J} + \mathbf{J}_d$  .... (12)

By taking divergence on both side of equation (12), we will get  $\nabla \cdot (\nabla \times \mathbf{H}) = \nabla \cdot \mathbf{J} + \nabla \cdot \mathbf{J}_d$

As the divergence of curl of a vector is always zero, therefore  $\nabla \cdot (\nabla \times \mathbf{H}) = 0$

So,  $\nabla \cdot (\mathbf{J} + \mathbf{J}_d) = 0$  Or  $\nabla \cdot \mathbf{J} = -\nabla \cdot \mathbf{J}_d$

But from equation of continuity for time varying fields,  $\nabla \cdot \mathbf{J} = -\frac{\partial \rho}{\partial t}$

From the above two equations of  $\mathbf{j}$ , we get

$$\nabla \cdot \mathbf{J}_d = \frac{d(\nabla \cdot \mathbf{D})}{dt} \quad \dots (13)$$

As from Maxwell's first equation  $\nabla \cdot \mathbf{D} = \rho$

Now, from equation (13) we can write  $\mathbf{J}_d = \frac{\partial \mathbf{D}}{\partial t}$

Using the above equation in equation (12), we get

$$\nabla \times \mathbf{H} = \mathbf{J} + \frac{\partial \mathbf{D}}{\partial t} \quad \dots (14)$$



Here,  $J_D = \frac{\partial D}{\partial t}$  = Displacement current density

The equation (14) is the **Differential form of Maxwell's fourth equation** or Modified Ampere's circuital law.

## 2.3 Integral form of Maxwell's equations

### 2.3.1 First Equation:

Gauss law of electrostatic states that the total electric flux  $\Phi_E$  coming out from a closed surface is equal to  $1/\epsilon_0$  times the net charge enclosed by the surface i.e.

$$\oiint \mathbf{E} \cdot d\mathbf{s} = q/\epsilon_0 \quad \dots(1)$$

Let  $\rho$  is the volume charge density distributed over a volume  $V$ .

Therefore,  $q = \int \rho \, dv$

$$\text{So, } \oiint \mathbf{E} \cdot d\mathbf{s} = \frac{1}{\epsilon_0} \int \rho \, dv \quad \dots(2)$$

This equation is the **integral form of Maxwell's first equation** or Gauss's law in electrostatics.

### 2.3.2 Second equation:

Gauss law of magnetostatic states that the total magnetic flux  $\Phi_m$  coming out through surface of a volume is always equal to zero i.e.

$$\Phi_m = \oiint \mathbf{B} \cdot d\mathbf{s} = 0 \quad \dots(3)$$

The above equation is the **integral form of Maxwell's second equation**. The above equation also suggest that magnetic monopole does not exist.

### 2.3.3 Third Equation:

1. It states that, if there is a change of magnetic flux linked with a circuit then electromotive force (emf) is induced in the circuit. This induced emf lasts as long as the change in magnetic flux continues. 2. The magnitude of induced emf is equal to the rate of change of magnetic flux linked with the circuit.

$$\text{Therefore, } \text{induced emf} = \frac{d\phi_m}{dt} \quad \dots(4)$$

$$\text{Where, } \phi_m = \iint \mathbf{B} \cdot d\mathbf{s} \quad \dots(5)$$

Here negative sign indicates the induced emf set up a current in such a direction that the magnetic effect produced by it opposes the cause producing it.

Again we know emf is the closed line integral of the non-conservative electric field generated by the battery.

$$\text{That is } \text{emf} = \oint \mathbf{E} \cdot d\mathbf{l} \quad \dots(6)$$

Using equations (5) and (6), in equation (4) we get

$$\oint \mathbf{E} \cdot d\mathbf{l} = - \iint \frac{\partial \mathbf{B}}{\partial t} \cdot d\mathbf{s} \quad \dots(7)$$

The above equation is the **integral form of Maxwell's third Equation** or Faraday's law of electromagnetic induction.

### 2.3.4 Fourth equation:

The line integration of the magnetic field  $\mathbf{H}$  around a closed path or circuit is equal to the conduction current plus the time derivative of electric displacement through the surface bounded by the closed path i.e,

$$\oint \mathbf{H} \cdot d\mathbf{l} = \iint (\mathbf{J} + \frac{\partial \mathbf{D}}{\partial t}) \cdot d\mathbf{s} \quad \dots(8)$$

The above equation is the **integral form of Maxwell's fourth equation**.

### 2.5 Displacement Current:

According to Maxwell not only conduction current produces magnetic field but also time varying electric field produces magnetic field. This means that a changing electric field is equivalent to a current which flows as long as electric field is changing. This is current only in the sense that it produces same magnetic effect as conduction current does; there is no actual flow of electron.

If  $\mathbf{E}$  is the electric field developed between the plates of surface area  $\mathbf{A}$  Then the displacement current is given by  $I_d = \mathbf{A} \cdot \mathbf{J}_D = \mathbf{A} \cdot \frac{\partial \mathbf{D}}{\partial t} = \epsilon_0 \mathbf{A} \cdot \frac{\partial \mathbf{E}}{\partial t}$

### 2.6 Electromagnetic wave Equation in Free Space

Now in free space there is no charge so charge density  $\rho=0$  and current will also be zero. Thus, current density  $\mathbf{J}$  is also equal to zero.

Hence, Maxwell's equation in free space is given by

$$\nabla \cdot \mathbf{E} = 0 \quad \dots(1) \quad \text{where } (\mathbf{D} = \epsilon_0 \mathbf{E})$$

$$\nabla \cdot \mathbf{B} = 0 \quad \dots(2)$$

$$\nabla \times \mathbf{E} = -\frac{\partial \mathbf{B}}{\partial t} \quad \dots(3) \quad \text{where } (\mathbf{B} = \mu_0 \mathbf{H})$$

$$\nabla \times \mathbf{B} = \mu_0 \epsilon_0 \frac{\partial \mathbf{E}}{\partial t} \quad \dots(4) \quad \text{where } (\mathbf{J} = \sigma \mathbf{E})$$

### 2.6.1 Maxwell's Electromagnetic wave Equation in Free Space for the field vector $\mathbf{E}$

we take curl on both side of Maxwell's 3<sup>rd</sup> equation represented in equation (3).

$$\nabla \times (\nabla \times \mathbf{E}) = -\nabla \times \frac{\partial \mathbf{B}}{\partial t}$$

$$\nabla(\nabla \cdot \mathbf{E}) - \nabla^2 \mathbf{E} = -\frac{\partial(\nabla \times \mathbf{B})}{\partial t} \quad [(\text{using vector identity, } \nabla \times (\nabla \times \mathbf{E}) = \nabla(\nabla \cdot \mathbf{E}) - \nabla^2 \mathbf{E} )]$$

Now, from equation (1) and (4) in the above equation

$$\nabla^2 \mathbf{E} = \frac{\partial(\mu_0 \epsilon_0 \frac{\partial \mathbf{E}}{\partial t})}{\partial t}$$

$$\text{Or, } \nabla^2 \mathbf{E} = \mu_0 \epsilon_0 \frac{\partial^2 \mathbf{E}}{\partial t^2} \quad \dots(5)$$

Similarly, we can find an equation for the field vector  $\mathbf{B}$ , when we take the Maxwell's 4<sup>th</sup> and repeat the process of field vector  $\mathbf{E}$ .

$$\nabla^2 \mathbf{B} = \mu_0 \epsilon_0 \frac{\partial^2 \mathbf{B}}{\partial t^2} \quad \dots(6)$$

Equation (5) and (6) is the guiding equation for field vector  $\mathbf{E}$  and  $\mathbf{B}$  respectively in free space.

Thus, we can see that time varying electric field produces magnetic field and time varying magnetic field produces electric field and follow the above guiding equation. Comparing the above equation with the

standard wave equation'  $U = \frac{1}{v^2} \frac{\partial^2 U}{\partial t^2}$ , -----(7)

Compare equation (6) and (7), we get

$$v = \frac{1}{\sqrt{\mu_0 \epsilon_0}} = \sqrt{\frac{1}{\mu_0 \epsilon_0}} = \sqrt{\frac{4\pi}{\mu_0} \times \frac{1}{4\pi \epsilon_0}}$$

$$\text{Because } \left\{ \frac{4\pi}{\mu_0} \times \frac{1}{4\pi \epsilon_0} = 10^7 \times 9 \times 10^9 \right\}$$

Hence,  $v = 3 \times 10^8 \text{ m/s} = c$

Hence, this field vectors propagates in free space with the speed of light. So, from here Maxwell concluded that light is an electromagnetic wave.

## 2.7 Electromagnetic wave Equation in non-conducting medium

Now in non-conducting medium there is no free charge, so current density  $\mathbf{J}$  and total charge inside the material is zero, so charge density  $\rho$  is also equal to zero. Maxwell's equation in a non-conducting medium of permittivity  $\epsilon = \epsilon_r \epsilon_0$  and permeability  $\mu = \mu_r \mu_0$  is reduces to

$$\nabla \cdot \mathbf{E} = 0 \quad \text{.....(1)} \quad \text{where } (\mathbf{D} = \epsilon \mathbf{E})$$

$$\nabla \cdot \mathbf{B} = 0 \quad \text{.....(2)}$$

$$\nabla \times \mathbf{E} = -\frac{\partial \mathbf{B}}{\partial t} \quad \text{.....(3)} \quad \text{where } (\mathbf{B} = \mu \mathbf{H})$$

$$\nabla \times \mathbf{B} = \mu \epsilon \frac{\partial \mathbf{E}}{\partial t} \quad \text{.....(4)} \quad \text{where } (\mathbf{J} = \sigma \mathbf{E})$$

### 2.7.1 Maxwell's Electromagnetic wave Equation in Free Space for the field vector E

we take curl on both side of Maxwell's 3<sup>rd</sup> equation represented in equation (3).

$$\nabla \times (\nabla \times \mathbf{E}) = -\nabla \times \frac{\partial \mathbf{B}}{\partial t}$$

$$\nabla(\nabla \cdot \mathbf{E}) - \nabla^2 \mathbf{E} = -\frac{\partial(\nabla \times \mathbf{B})}{\partial t} \quad [(\text{using vector identity, } \nabla \times (\nabla \times \mathbf{E}) = \nabla(\nabla \cdot \mathbf{E}) - \nabla^2 \mathbf{E} )]$$

Now, using equation (1) and (4) in the above equation

$$\nabla^2 \mathbf{E} = \frac{\partial(\mu\epsilon \frac{\partial \mathbf{E}}{\partial t})}{\partial t}$$

$$\text{Or, } \nabla^2 \mathbf{E} = \mu\epsilon \frac{\partial^2 \mathbf{E}}{\partial t^2} \quad \dots(5)$$

Similarly, we can find an equation for the field vector  $\mathbf{B}$ , when we take the Maxwell's 4<sup>th</sup> and repeat the process of field vector  $\mathbf{E}$ .

$$\nabla^2 \mathbf{B} = \mu\epsilon \frac{\partial^2 \mathbf{B}}{\partial t^2} \quad \dots(6)$$

Equation (5) and (6) is the guiding equation for field vector  $\mathbf{E}$  and  $\mathbf{B}$  respectively in non-conducting medium.

Comparing the above equation with the standard wave equation  $\nabla^2 U = \frac{1}{v^2} \frac{\partial^2 U}{\partial t^2}$ , -----(7)

we can see that this field vectors propagate in non-conducting medium with a speed

$$v = \frac{1}{\sqrt{\mu\epsilon}} = \frac{1}{\sqrt{\mu_r \mu_0 \epsilon_r \epsilon_0}} = \frac{c}{\sqrt{\mu_r \epsilon_r}}, \quad \text{As } c = \frac{1}{\sqrt{\mu_0 \epsilon_0}}$$

For non-magnetic medium  $\mu_r=1$

$$\text{So, } v = \frac{c}{\sqrt{\epsilon_r}} = \frac{c}{n} \quad \text{here } \sqrt{\epsilon_r} = n \text{ is the refractive index of the medium.}$$

Hence, electromagnetic wave propagate in non-conducting medium with a speed  $\frac{1}{n}$  times the speed of electromagnetic wave in free space.

## 2.8 Transverse nature of electromagnetic wave

Science we know that the plane electromagnetic wave equation are

$$\nabla^2 \mathbf{E} = \mu_0 \epsilon_0 \frac{\partial^2 \mathbf{E}}{\partial t^2} \quad \text{---(1)}$$

$$\nabla^2 \mathbf{B} = \mu \epsilon \frac{\partial^2 \mathbf{B}}{\partial t^2} \quad \text{---(2)}$$

Solution of these wave equation, considering the propagation of the wave in any arbitrary direction of three dimensional space is given by

$$\vec{E} = \vec{E}_0 \exp(i\vec{k} \cdot \vec{r} - i\omega t) \quad \text{... (3)}$$

$$\vec{B} = \vec{B}_0 \exp(i\vec{k} \cdot \vec{r} - i\omega t) \quad \text{... (4)}$$

Where  $E_0$  and  $B_0$  are the amplitudes of electric and magnetic field respectively and  $\vec{k}$  is propagation vector given by  $\vec{k} = k\hat{n} = 2\pi/\lambda = 2\pi\nu/c = \omega/c$ .

Now, Maxwell's first and second equation in free space is

$$\vec{\nabla} \cdot \vec{E} = 0 \quad \text{... (5)}$$

$$\vec{\nabla} = \hat{i} \frac{\partial}{\partial x} + \hat{j} \frac{\partial}{\partial y} + \hat{k} \frac{\partial}{\partial z} \quad \vec{E}_0 = \hat{i}E_{0x} + \hat{j}E_{0y} + \hat{k}E_{0z} \quad \vec{\nabla} \cdot \vec{B} = 0 \quad \text{... (6)}$$

Where and

Putting the above expressions in L. H. S of equation (5)

$$\vec{\nabla} \cdot \vec{E} = (\hat{i} \frac{\partial}{\partial x} + \hat{j} \frac{\partial}{\partial y} + \hat{k} \frac{\partial}{\partial z}) \cdot \vec{E}_0 \exp(i\vec{k} \cdot \vec{r} - i\omega t) \quad \text{----- (7)}$$

Where  $\vec{k} = \hat{i}k_x + \hat{j}k_y + \hat{k}k_z$  and  $\vec{r} = \hat{i}x + \hat{j}y + \hat{k}z$

So,  $\vec{k} \cdot \vec{r} = xk_x + yk_y + zk_z$

Thus equation (7) can be written as

$$\vec{\nabla} \cdot \vec{E} = (\hat{i} \frac{\partial}{\partial x} + \hat{j} \frac{\partial}{\partial y} + \hat{k} \frac{\partial}{\partial z}) \cdot (\hat{i}E_{0x} + \hat{j}E_{0y} + \hat{k}E_{0z}) \exp \{i(xk_x + yk_y + zk_z) - i\omega t\}$$

$$\vec{\nabla} \cdot \vec{E} = \frac{\partial}{\partial x} [E_{0x} \exp i \{(xk_x + yk_y + zk_z) - \omega t\}] + \frac{\partial}{\partial y} [E_{0y} \exp i \{(xk_x + yk_y + zk_z) - \omega t\}] + \frac{\partial}{\partial z} [E_{0z} \exp i \{(xk_x + yk_y + zk_z) - \omega t\}]$$

$$\vec{\nabla} \cdot \vec{E} = (ik_x) E_{0x} \exp i \{(xk_x + yk_y + zk_z) - \omega t\} + (ik_y) E_{0y} \exp i \{(xk_x + yk_y + zk_z) - \omega t\} + (ik_z) E_{0z} \exp i \{(xk_x + yk_y + zk_z) - \omega t\}$$

$$\vec{\nabla} \cdot \vec{E} = [E_{0x} k_x + E_{0y} k_y + E_{0z} k_z] \exp i \{(xk_x + yk_y + zk_z) - \omega t\}$$

$$\vec{\nabla} \cdot \vec{E} = \hat{k} \cdot \vec{E}_0 = (k_x E_{0x} + k_y E_{0y} + k_z E_{0z}) \exp i \{(xk_x + yk_y + zk_z) - \omega t\}$$

$$\vec{\nabla} \cdot \vec{E} = i(\vec{k} \cdot \vec{E}_0) \exp(i\vec{k} \cdot \vec{r} - \omega t) \quad \text{using equation (3).}$$

Now putting the value of  $\vec{\nabla} \cdot \vec{E}$  in equation (5)

$$\vec{\nabla} \cdot \vec{E} = i\vec{k} \cdot \vec{E} = 0$$

$$\text{Or } \vec{k} \cdot \vec{E} = 0 \quad \dots\dots (8)$$

Similarly, putting equation (4) in equation (6) we will get  $\vec{k} \cdot \vec{B} = 0 \quad \dots\dots(9)$

**Equation (8) & (9) suggest that electric and magnetic field vectors are perpendicular to propagation vector. So, we can say that electromagnetic waves are transverse in nature.**

Again, using Maxwell's 3<sup>rd</sup> and 4<sup>th</sup> equations in free space are

$$\vec{\nabla} \times \vec{E} = -\frac{\partial \vec{B}}{\partial t} \quad \dots\dots(10)$$

$$\vec{\nabla} \times \vec{B} = \mu_0 \epsilon_0 \frac{\partial \vec{E}}{\partial t} \quad \dots\dots(11)$$

Now, if we put the expression of  $\vec{E}$  from equation (3) in above Maxwell's equation (equation No. 10) then we can write

$$i[\vec{k} \times \vec{E}] = -\frac{\partial}{\partial t} [\vec{B}_0 \exp(i\vec{k} \cdot \vec{r} - \omega t)] \\ = -(-i\omega) \vec{B}_0 \exp(i\vec{k} \cdot \vec{r} - \omega t)$$

$$\vec{k} \times \vec{E} = \omega \vec{B} \quad \dots\dots(12)$$



Similarly, putting the expression of  $\vec{B}$  from equation (4) in equation (12) we will get

$$\vec{K} \times \vec{B} = -\omega \mu_0 \epsilon_0 \vec{E} \text{ -----(13)}$$

From equation (12) we can say magnetic field vector is perpendicular to both  $\vec{E}$  &  $\vec{K}$  and from (13) we can say Electric field vector is perpendicular to both  $\vec{K}$  and  $\vec{B}$ . **Thus electric field vector, magnetic field vector and propagation vector are mutually perpendicular to each other.**

### Characteristic Impedance

As  $\vec{E}$  &  $\vec{K}$  are perpendicular to each other and  $\vec{E}$ ,  $\vec{B}$  &  $\vec{K}$  are mutually perpendicular, so from equation (12)

$$\vec{K} \times \vec{E} = \omega \vec{B}$$

$$kE = \omega B$$

$$\text{Or, } \frac{E}{B} = \frac{\omega}{k}$$

$$\text{Or, } \frac{E}{B} = \frac{\omega}{k} = \frac{2\pi v \lambda}{2\pi} = v\lambda = c$$

$$\text{Thus, } \frac{E}{B} = c$$

$$\text{Or, } \frac{E}{H} = \mu_0 c \quad \text{and} \quad c = \frac{1}{\sqrt{\mu_0 \epsilon_0}}$$

$$\text{Or, } \frac{E}{H} = \frac{\mu_0}{\sqrt{\mu_0 \epsilon_0}} = \sqrt{\frac{\mu_0}{\epsilon_0}} = 376.72 \Omega$$

The quantity  $\frac{E}{H} = Z_0 = 376.72 \Omega$  is known as characteristic Impedance or Intrinsic Impedance of free space.

## 2.9 Energy in an electromagnetic field

The Energy of electromagnetic Wave is the sum of electric (**E**) and magnetic (**B**) field energy.

The electric energy per unit volume is given by  $U_E = \frac{\epsilon_0 E^2}{2}$

The magnetic energy per unit volume is given by  $U_B = \frac{B^2}{2\mu_0}$

So, the total energy per unit volume in electromagnetic wave is

$$U = \frac{\epsilon_0 E^2}{2} + \frac{B^2}{2\mu_0}$$

$$\frac{E}{AsB} = c \text{ and } \frac{1}{\sqrt{\mu_0 \epsilon_0}}; \text{ So, } U = \frac{\epsilon_0 E^2}{2} + \frac{E^2}{2\mu_0 c^2} = \frac{\epsilon_0 E^2}{2} + \frac{\epsilon_0 E^2}{2} = \epsilon_0 E^2$$

Therefore, energy per unit volume in electromagnetic wave is  $U = \epsilon_0 E^2$

### 2.10 Skin Depth

Skin depth or depth of penetration is defined as the depth in which the strength of electric field associated with electromagnetic wave reduces to  $1/e$  times of its initial value. The figure below shows the variation of field vector  $\mathbf{E}$  with distance of electromagnetic wave inside a conducting medium and the value of skin

depth inside a good conductor is given by  $\delta = \sqrt{\frac{2}{\omega \sigma}}$ ; Here  $\sigma$  is the conductivity of the medium and  $\omega$  is angular frequency of the electromagnetic wave.

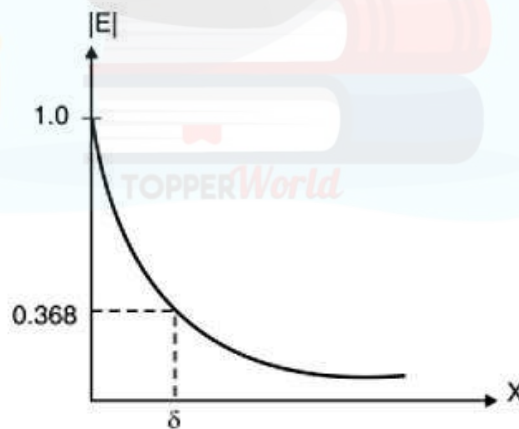

### 2.11 Poynting vector and Poynting Theorem

**Poynting vector:** When electromagnetic wave propagates through space it carries energy with it. The amount of energy passing through unit area in the perpendicular to direction of propagation of the electromagnetic wave per second is given by  $\mathbf{S} = \mathbf{E} \times \mathbf{H}$

This quantity  $\mathbf{S}$  is called **Poynting vector**.  $\mathbf{E}$  electric field vector and  $\mathbf{H}$  is magnetic field vector of the electromagnetic wave. The direction of  $\mathbf{S}$  is perpendicular to  $\mathbf{E}$  and  $\mathbf{H}$  and in the direction of vector  $\mathbf{E} \times \mathbf{H}$ .

**Theorem:** Consider Maxwell's fourth equation (Modified Ampere's Circuital Law), that is

$$\nabla \times \mathbf{H} = \mathbf{J} + \epsilon \, d\mathbf{E}/dt$$

or 
$$\mathbf{J} = (\nabla \times \mathbf{H}) - \epsilon \, d\mathbf{E}/dt$$

The above equation has the dimensions of current density. Now, to convert the dimensions into rate of energy flow per unit volume, take dot product of both sides of above equation by  $\mathbf{E}$ , that is

$$\mathbf{E} \cdot \mathbf{J} = \mathbf{E} \cdot (\nabla \times \mathbf{H}) - \epsilon \mathbf{E} \cdot d\mathbf{E}/dt \quad (1)$$

Now using vector Identity

$$\begin{aligned} \nabla \cdot (\mathbf{E} \times \mathbf{H}) &= \mathbf{H} \cdot (\nabla \times \mathbf{E}) - \mathbf{E} \cdot (\nabla \times \mathbf{H}) \text{ or} \\ \mathbf{E} \cdot (\nabla \times \mathbf{H}) &= \mathbf{H} \cdot (\nabla \times \mathbf{E}) - \nabla \cdot (\mathbf{E} \times \mathbf{H}) \end{aligned}$$

By substituting value of  $\mathbf{E} \cdot (\nabla \times \mathbf{H})$  in equation (1), we get

$$\mathbf{E} \cdot \mathbf{J} = \mathbf{H} \cdot (\nabla \times \mathbf{E}) - \nabla \cdot (\mathbf{E} \times \mathbf{H}) - \epsilon \mathbf{E} \cdot d\mathbf{E}/dt \quad (2)$$

Also from Maxwell's third equation (Faraday's law of electromagnetic induction).

$$\nabla \times \mathbf{E} = -\mu \, d\mathbf{H}/dt$$

By substituting value of  $\nabla \times \mathbf{E}$  in equation (2) we get

$$\mathbf{E} \cdot \mathbf{J} = \mu \mathbf{H} \cdot d\mathbf{H}/dt - \epsilon \mathbf{E} \cdot d\mathbf{E}/dt - \nabla \cdot (\mathbf{E} \times \mathbf{H}) \quad (3)$$

We can write

$$\mathbf{H} \cdot d\mathbf{H}/dt = 1/2 \, dH^2/dt \quad (4a)$$

$$\mathbf{E} \cdot d\mathbf{E}/dt = 1/2 \, dE^2/dt \quad (4b)$$

By substituting equations 4a and 4b in equation 3, we get

$$\mathbf{E} \cdot \mathbf{J} = -\mu/2 \, dH^2/dt - \epsilon/2 \, dE^2/dt - \nabla \cdot (\mathbf{E} \times \mathbf{H})$$

$$\mathbf{E} \cdot \mathbf{J} = -\frac{d}{dt}(\frac{\mu H^2}{2} + \frac{\epsilon E^2}{2}) - \nabla \cdot (\mathbf{E} \times \mathbf{H})$$

By taking volume integral on both sides, we get

$$\iiint \mathbf{E} \cdot \mathbf{J} dV = -\frac{d}{dt} \iiint (\frac{\mu H^2}{2} + \frac{\epsilon E^2}{2}) dV - \iiint \nabla \cdot (\mathbf{E} \times \mathbf{H}) dV \quad (5)$$

Applying Gauss's Divergence theorem to second term of R.H.S., to change volume integral into surface integral, that is

$$\iiint \nabla \cdot (\mathbf{E} \times \mathbf{H}) dV = \oiint (\mathbf{E} \times \mathbf{H}) \cdot d\mathbf{s}$$

Substitute above equation in equation (5)

$$\iiint \mathbf{E} \cdot \mathbf{J} dV = -\frac{d}{dt} \iiint (\frac{\mu H^2}{2} + \frac{\epsilon E^2}{2}) dV - \oiint \mathbf{E} \times \mathbf{H} \cdot d\mathbf{s} \quad (6)$$

$$\text{or} \quad \oiint \mathbf{E} \times \mathbf{H} \cdot d\mathbf{s} = -\iiint [\frac{d}{dt}(\frac{\mu H^2}{2} + \frac{\epsilon E^2}{2})] dV - \iiint \mathbf{E} \cdot \mathbf{J} dV$$

**Interpretation of above equation:**

**L.H.S. Term**

$\oiint \mathbf{E} \times \mathbf{H} \cdot d\mathbf{s}$  → It represents the rate of outward flow of energy through the surface of a volume  $V$  and the integral is over the closed surface surrounding the volume. This rate of outward flow of power from a volume  $V$  is represented by

$$\oiint \mathbf{S} \cdot d\mathbf{s} = \oiint \mathbf{E} \times \mathbf{H} \cdot d\mathbf{s}$$

where Poynting vector,  $\mathbf{S} = \mathbf{E} \times \mathbf{H}$

Inward flow of power is represented by  $-\oiint \mathbf{S} \cdot d\mathbf{s} = -\oiint \mathbf{E} \times \mathbf{H} \cdot d\mathbf{s}$

**R.H.S. First Term**

$-\iiint [\frac{d}{dt}(\frac{\mu H^2}{2} + \frac{\epsilon E^2}{2})] dV$  → If the energy is flowing out of the region, there must be a corresponding decrease of electromagnetic energy. So here negative sign indicates decrease.

Electromagnetic energy is the sum of magnetic energy,  $\mu H^2/2$  and electric energy,  $\epsilon E^2/2$ . So, first term of R.H.S. represents rate of decrease of stored electromagnetic energy.

**R.H.S. Second Term**

$-\iiint \mathbf{E} \cdot \mathbf{J} \, dV \rightarrow$  Total ohmic power dissipated within the volume.

**So, from the law of conservation of energy, equation (6) can be written in words as**

Rate of energy dissipation in volume  $V$  = Rate at which stored electromagnetic energy is decreasing in  $V$   
+ Inward rate of flow of energy through the surface of the volume.

**2.12 Radiation Pressure:**

The electromagnetic waves exert a “Radiation Pressure” on a surface due to absorption and reflection of the electromagnetic wave. An object absorbing an electromagnetic wave would experience a force in the direction of propagation of the wave. During these processes momentum is exchanged between the surface and the electromagnetic wave.

Consider an e.m wave of average energy density  $\langle u \rangle$  and average poynting vector  $\langle S \rangle$  be incident normally on a surface then the radiation pressure  $P$ , exerted by e.m waves on this surface is :

$$P = \frac{\langle F \rangle}{A} \dots (1)$$

where  $\langle F \rangle$  is the average force exerted by the e.m waves.

Now, using Newton’s Second Law,

$$\langle F \rangle = \frac{d\langle P \rangle}{dt} \dots (2)$$

Where,  $\langle P \rangle$  is the momentum of incident e.m waves.

For electromagnetic wave, we know that ,

$$\langle P \rangle = \frac{\langle E \rangle}{c} \dots (3)$$

Putting equation ( 3 ) in ( 2 )

Module-2-Electromagnetic Field TheoryCO2

$$\langle F \rangle = \frac{d\langle E/c \rangle}{dt} \dots(4)$$

Since  $S = \text{Power}/\text{Area}$  and  $\text{Power} = \text{Energy}/\text{Time}$

$$\text{Therefore } S = \frac{\text{Energy}}{\text{Area} \cdot \text{Time}}$$

$$\text{So, we can write } \langle S \rangle = \frac{d\langle E \rangle}{A \cdot dt}$$

$$\langle S \rangle A = \frac{d\langle E \rangle}{dt} \dots(5)$$

Now using equation ( 5 ) in ( 4 )

$$\langle F \rangle = \langle S \rangle A/c \dots(6)$$

Using equation ( 6 ) in ( 1 ) radiation pressure due to absorption of electromagnetic wave is  $P = \frac{\langle S \rangle}{c}$

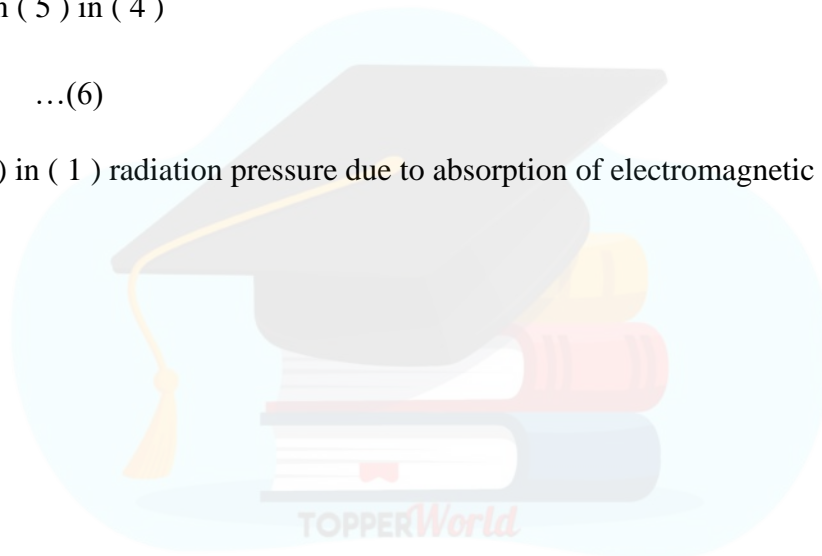



### **BLACKBODY RADIATION SPECTRUM**

A blackbody is an object that absorbs all of the radiation that it receives (that is, it does not reflect any light, nor does it allow any light to pass through it and out the other side). The energy that the blackbody absorbs heats it up, and then it will emit its own radiation. The only parameter that determines how much light the blackbody gives off, and at what wavelengths, is its temperature. There is no object that is an ideal blackbody, but many objects (stars included) behave approximately like blackbodies. Other common examples are the filament in an incandescent light bulb or the burner element on an electric stove. As you increase the setting on the stove from low to high, you can observe it produce blackbody radiation; the element will go from nearly black to glowing red hot.

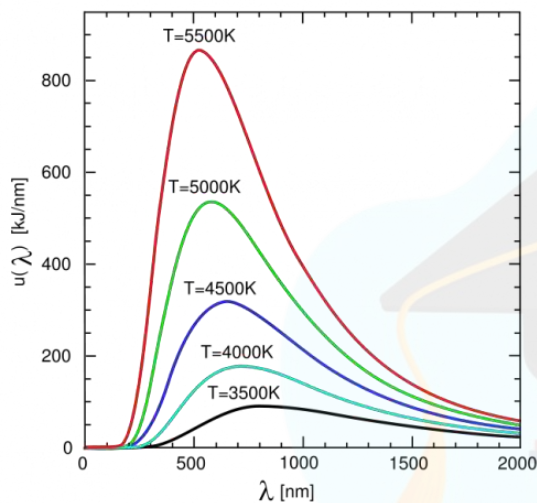

**Plot of the spectrum of a blackbody with different temperatures**

*The spectrum of a blackbody is continuous (it gives off some light at all wavelengths), and it has a peak at a specific wavelength. The peak of the blackbody curve in a spectrum moves to shorter wavelengths for hotter objects*

### **Rayleigh-Jeans radiation law**

The Rayleigh-Jeans Radiation Law was a useful but not completely successful attempt at establishing the functional form of the spectra of thermal radiation. The energy density  $u_\nu$  per unit frequency interval at a frequency  $\nu$  is, according to the Rayleigh-Jeans Radiation,

$$u_\nu = \frac{8\pi\nu^2 kT}{c^3} d\nu \quad (1)$$

where  $k$  is Boltzmann's constant,  $T$  is the absolute temperature of the radiating body and  $c$  is the speed of light in a vacuum. This formula fits the empirical measurements for low frequencies but fails increasingly for higher frequencies. The failure of the formula to match the new data was called the ultraviolet catastrophe. The significance of this inadequate so-called law is that it provides an asymptotic condition which other proposed formulas, such as Planck's, need to satisfy. It gives a value to an otherwise arbitrary constant in Planck's thermal radiation formula.



**Stefan's Law**

The spectrum of radiation emitted by a solid material is a continuous spectrum, unlike the line spectrum emitted by the same material in gaseous form. The peak frequency of the emitted spectrum increases with the temperature of the solid body, as does the total power radiated.

**Definition :** According to the Stefan-Boltzmann law, the total power radiated by an ideal emitter (perfect blackbody) is proportional to the fourth power of the absolute temperature.

$$P = A\sigma T^4$$

Where ,

**P** = total power radiated from the blackbody

**A** = surface area of the blackbody

**$\sigma$**  = Stefan-Boltzmann constant

**T** = Absolute temperature of the

blackbody

To generalize ,

$$P = \epsilon A\sigma T^4$$

Where ,  **$\epsilon$**  is the emissivity

And ,

**$\epsilon$**  = 1 for black body

**$\epsilon$**  < 1 for grey bodies (not perfect blackbody)

**Wien's Displacement Law**

When the temperature of a blackbody radiator increases, the overall radiated energy increases and the peak of the radiation curve moves to shorter wavelengths. When the maximum is evaluated from the Planck radiation formula, the product of the peak wavelength and the temperature is found to be a constant.

$$\lambda_m T = 2.898 \times 10^{-3} \text{ mK} \quad (2)$$

This relationship is called **Wien's displacement law** and is useful for the determining the temperatures of hot radiant objects such as stars, and indeed for a determination of the temperature of any radiant object whose temperature is far above that of its surroundings.

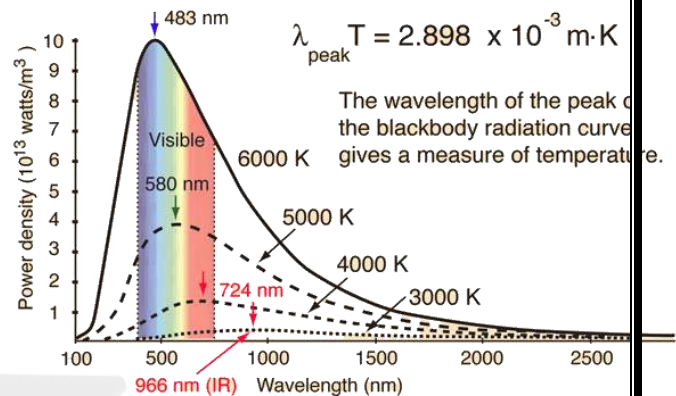

Ref: <http://hyperphysics.phy-astr.gsu.edu/hbase/wien.html>

**Wien's Distribution law**

William Wien used thermodynamics to show that the spectral energy density of a blackbody between the wavelength range  $\lambda$  and  $\lambda+d\lambda$  is given by :

$$E_\lambda d\lambda = A_\lambda f(\lambda T) d\lambda \quad \dots (1)$$

Wien found, using the Maxwell-Boltzmann distribution law for the speed of atoms (or molecules) in a gas, that the form of the function  $f(\lambda T)$  was :

$$f(\lambda T) = e^{-\alpha/\lambda T} \quad \dots (2)$$

And therefore ,

$$E_\lambda d\lambda = A \lambda^{-5} e^{-\alpha/\lambda T} d\lambda \quad \dots (3)$$

Where A and  $\alpha$  are constants to be determined.

Equation (3) is known as **Wien's Distribution Law**.

**Assumption of Quantum Theory of Radiation**

The distribution of energy in the spectrum of radiations of a hot body cannot be explained by applying the classical concepts of physics. Max Planck gave an explanation to this observation by his Quantum Theory of Radiation. His theory says:

- The radiant energy is always in the form of tiny bundles of light called quanta i.e. the energy is absorbed or emitted discontinuously.
- Each quantum has some definite energy  $E=h\nu$ , which depends upon the frequency ( $\nu$ ) of the radiations. where,  $h$  = Planck's constant =  $6.626 \times 10^{-34}$ Js.
- The energy emitted or absorbed by a body is always a whole multiple of a quantum i.e.  $nh\nu$ . This concept is known as quantization of energy.

**Planck's Law(or Planck's Radiation Law)**

Planck's radiation law is derived by assuming that each radiation mode can be described by a quantized harmonic oscillator with energy  $E_n = nh\nu$

Let  $N_0$  be the number of oscillators with zero energy i.e  $E_0$  (in the so-called ground-state), then the numbers in the 1st, 2nd, 3rd etc. levels ( $N_1, N_2, N_3, \dots$ ) are given by:

$$N_1 = N_0 \exp\left(\frac{-E_1}{kT}\right) ; N_2 = N_0 \exp\left(\frac{-E_2}{kT}\right) ; N_3 = N_0 \exp\left(\frac{-E_3}{kT}\right)$$

But since  $E_n = nh\nu$

$$N_1 = N_0 \exp\left(\frac{-h\nu}{kT}\right) ; N_2 = N_0 \exp\left(\frac{-2h\nu}{kT}\right) ; N_3 = N_0 \exp\left(\frac{-3h\nu}{kT}\right)$$

The total number of oscillators  $N = N_0 + N_1 + N_2 + N_3 + \dots$

$$\text{The total energy } E = h\nu N_0 \exp\left(\frac{-h\nu}{kT}\right) + 2h\nu N_0 \exp\left(\frac{-2h\nu}{kT}\right) + 3h\nu N_0 \exp\left(\frac{-3h\nu}{kT}\right) + \dots$$

The avg .energy  $\langle E \rangle = \frac{E}{N}$

$$h\nu N_0 \left[ \exp\left(\frac{-h\nu}{kT}\right) + \left(\frac{-2h\nu}{kT}\right) + \left(\frac{-3h\nu}{kT}\right) + \dots \right]$$

$$\langle E \rangle = \frac{[1 + \exp(-\frac{h\nu}{kT}) + \exp(-\frac{2h\nu}{kT}) + \dots]}{N_0 h\nu \exp(-\frac{h\nu}{kT})}$$

$$\langle E \rangle = \frac{h\nu}{[1 - \exp(-\frac{h\nu}{kT})]}$$

$$\langle E \rangle = \frac{h\nu}{[\exp(\frac{h\nu}{kT}) - 1]} \quad (4)$$

According to Rayleigh-Jeans law, using classical physics, the energy density  $u_\nu$  per frequency interval was given by:

$$u_\nu = 8\pi\nu^2 kT d\nu \quad (5)$$

where  $kT$  was the energy of each mode of the electromagnetic radiation. We need to replace the  $kT$  in this equation with the average energy for the harmonic oscillators that we have just derived above. So, we rewrite the energy density as

TOPPERWorld

$$u_{\nu} = \frac{8\pi c^3}{15} \left[ \frac{h\nu}{kT} \right]^{-3} \frac{1}{\exp\left(\frac{h\nu}{kT}\right) - 1} h\nu \quad dv \quad (6)$$

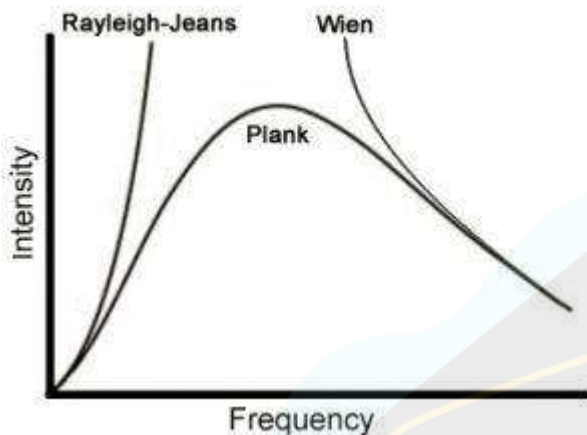

Comparison of Rayleigh Jeans, Wien's & Planck's Radiation Laws for the blackbody radiation spectrum.

### WAVE PARTICLE DUALITY

In physics and chemistry, wave-particle duality holds that light and matter exhibit properties of both waves and of particles. A central concept of quantum mechanics, duality addresses the inadequacy of conventional concepts like "particle" and "wave" to meaningfully describe the behaviour of quantum objects.

Publicized early in the debate about whether light was composed of particles or waves, a wave-particle dual nature soon was found to be characteristic of electrons as well. The evidence for the description of light as waves was well established at the turn of the century when the *photoelectric effect* introduced firm evidence of a *particle nature of light* as well. On the other hand, the particle properties of electron was well documented when the DeBroglie hypothesis and the subsequent experiments by Davisson and Germer established the *wave nature of the electron*.

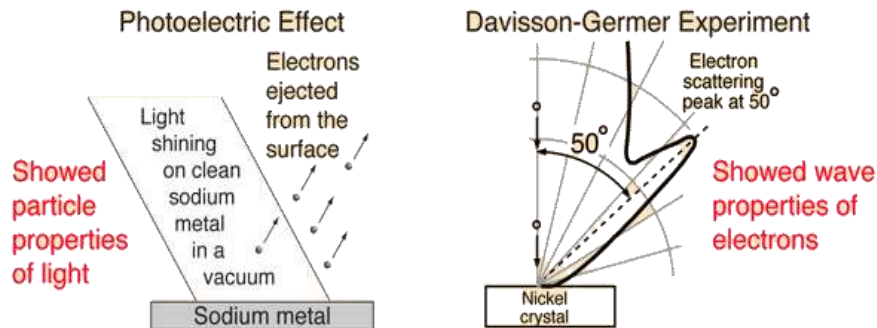

Ref: <http://hyperphysics.phy-astr.gsu.edu/hbase/mod1.html>

## De Broglie Matter Waves

### De Broglie Hypothesis

In 1924, Lewis de-Broglie proposed that matter has dual characteristic just like radiation. His concept about the dual nature of matter was based on the following observations:-

- The whole universe is composed of matter and electromagnetic radiations. Since both are forms of energy so can be transformed into each other.
- The matter loves symmetry. As the radiation has dual nature, matter should also possess dual character.

According to the de Broglie concept of matter waves, the matter has dual nature. It means when the matter is moving it shows the wave properties (like interference, diffraction etc.) are associated with it and when it is in the state of rest then it shows particle properties. Thus the matter has dual nature. The waves associated with moving particles are matter waves or de-Broglie waves.

$$\lambda = \frac{h}{mv} \quad .(7)$$

where,  $\lambda$  = de Broglie wavelength associated with the particle,  $h$  = Planck's constant,  $m$  = relativistic mass of the particle and  $v$  = velocity of the particle

**Phase velocity/Group Velocity (MATTER WAVES)**

The **phase velocity** of a wave is the rate at which the phase of the wave propagates in space. This is the velocity at which the phase of any one frequency component of the wave travels.

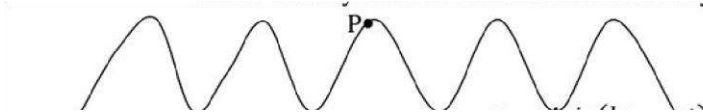

Let P be a phase point located on a travelling wave represented by the equation :  $y = A\sin(kx - \omega t)$  where,

$$k = 2\pi/\lambda \text{ is the wave number}$$

$$\omega = 2\pi\nu \text{ is the angular frequency}$$

then the phase velocity is given by:

$$v_p = v\lambda = \frac{\omega}{k} \quad (8)$$

$$\text{Also, } v = \frac{E}{h\nu} \text{ and } E = mc^2 \quad (9)$$

$$\lambda = \frac{h}{p} \text{ and} \quad (10)$$

$$p = mv$$

Substituting (9) and (10) in (8), we obtain  $v_p = \frac{E}{p} = \frac{c}{v} \times c$

The velocity of the phase point will be the same as the wave velocity.

As already mentioned  $v =$  velocity of the particle associated with the wave. Therefore,

For Photon  $v = c$  ; so in vacuum  $v_p = c$

For other particles  $v < c$  , but  $v_p > c$  which has no physical significance.

For a physically significant representation of matter waves , we require a wave packet to be associated with the moving particle(or body).

Group velocity :

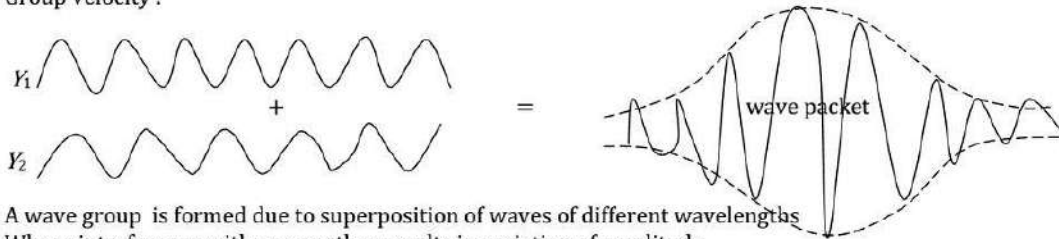

A wave group is formed due to superposition of waves of different wavelengths whose interference with one another results in variation of amplitude.

The velocity of the wave packet is called Group Velocity ,  $v_g = \frac{d\omega}{dk} = \frac{dE}{dp}$  (11)

### BORN INTERPRETATION OF THE WAVE FUNCTION AND ITS SIGNIFICANCE

Matter waves are represented by a complex function,  $\Psi(x,t)$ , which is called a wave function. The wave function is not directly associated with any physical quantity but the square of the wave function represents the probability density in a given region. The wave function should satisfy the following conditions:

- (i)  $\Psi$  should be finite
- (ii)  $\Psi$  should be single valued
- (iii)  $\Psi$  and its first derivative should be continuous
- (iv)  $\Psi$  should be normalizable,

$$\int_V |\Psi|^2 dV = 1 \quad , \text{ where } V = \text{volume in which the particle is expected to be found}$$

### SCHRODINGER'S WAVE EQUATION

#### TIME INDEPENDENT SCHRODINGER'S EQUATION

The classical wave equation that describes any type of wave motion can be given as:

$$\frac{\partial^2 y(x,t)}{\partial x^2} = \frac{1}{v^2} \frac{\partial^2 y(x,t)}{\partial t^2}$$

Where  $y$  is a variable quantity that propagates in 'x' direction with a velocity 'v'. Matter waves should also satisfy a similar equation and we can write the equation for matter waves as:

$$\frac{\partial^2 \Psi(x,t)}{\partial x^2} = \frac{1}{v^2} \frac{\partial^2 \Psi(x,t)}{\partial t^2} \quad (17)$$



We can eliminate the time dependence from the above equation by assuming a suitable form of the wave function and making appropriate substitutions.

$$\psi(x,t) = \psi_0(x)e^{-i\omega t} \quad (18)$$

Differentiate eqn. (18) w.r.t. 'x' successively to obtain

$$\frac{\partial^2 \psi(x,t)}{\partial x^2} = \frac{\partial^2 \psi_0(x)}{\partial x^2} e^{-i\omega t} \quad (19)$$

Differentiate eqn. (18) w.r.t. 't' successively to obtain

$$\frac{\partial \psi(x,t)}{\partial t} = -i\omega \psi_0(x) e^{-i\omega t} \quad (20)$$

Substituting (19) and (20) in equation (17)

$$\frac{\partial^2 \psi_0(x)}{\partial x^2} = -\frac{\omega^2}{v^2} \psi_0(x) = -k^2 \psi_0(x) \quad (21)$$

$$\frac{\partial^2 \psi_0(x)}{\partial x^2} + k^2 \psi_0(x) = 0 \quad (22)$$

Now we know the total energy 'E' of the particle is the sum of its kinetic energy and potential energy

$$\text{i.e. } E = \frac{p^2}{2m} + V \Rightarrow p^2 = 2m(E - V) \quad (23)$$

$$\text{Also } k = \frac{2\pi}{\lambda} \text{ and } \lambda = \frac{h}{p} \Rightarrow k^2 = \frac{4\pi^2}{h^2} p^2 \quad (24)$$

Substituting (23) in (24) in then substituting result in (22) we get

$$\frac{\partial^2 \psi_0(x)}{\partial x^2} + \frac{8m\pi^2(E-V)}{h^2} \psi_0(x) = 0 \quad (25)$$

Replacing  $\Psi_0(x)$  by  $\Psi(x)$  in eqn.(vii), we obtain the Schrodinger's time independent wave equation in one dimension

as:

$$\frac{\partial^2 \Psi(x)}{\partial x^2} + \frac{8m\pi^2(E-V)}{h^2} \Psi(x) = 0 \quad (26)$$

The above equation can be solved for different cases to obtain the allowed values of energy and the allowed wave functions.

### TIME DEPENDENT SCHRODINGER'S EQUATION

In the discussion of the particle in an infinite potential well, it was observed that the wave function of a particle of fixed energy  $E$  could most naturally be written as a linear combination of wave functions of the form

$$\psi(x,t) = Ae^{i(kx-\omega t)}$$

representing a wave travelling in the positive  $x$  direction, and a corresponding wave travelling in the opposite direction, so giving rise to a standing wave, this being necessary in order to satisfy the boundary conditions.

This corresponds intuitively to our classical notion of a particle bouncing back and forth between the walls of the potential well, which suggests that we adopt the wave function above as being the appropriate wave function for a *free* particle of momentum  $p = \hbar k$  and energy  $E = \hbar\omega$ . With this in mind, we can then note that



$$\frac{\partial^2 \psi(x)}{\partial x^2} = -k^2 \psi(x) \quad (27)$$

$$\text{which can be written, using } E = \frac{p^2}{2m} = \frac{\hbar^2 k^2}{2m} \quad (28)$$

From (28) and (27) we get,

$$\frac{-\hbar^2}{2m} \frac{\partial^2 \psi(x)}{\partial x^2} = \frac{p^2}{2m} \psi(x) \quad (29)$$

Similarly,

$$\frac{\partial \psi}{\partial t} = -i\omega \psi \quad (30)$$

$$\text{which can be written, using } E = \hbar\omega \quad (31)$$

From (30) and (31)

$$i\hbar \frac{\partial \psi}{\partial t} = E\psi \quad (32)$$

We now generalize this to the situation in which there is both a kinetic energy and a potential energy present, then  $E = p^2/2m + V(x)$  so that

$$E\psi = \frac{p^2\psi}{2m} + V(x)\psi \quad (33)$$

where  $\Psi$  is now the wave function of a particle moving in the presence of a potential  $V(x)$ .

But if we assume that the results above still apply in this case then we have by substituting (29) and (32) in (33)

$$\frac{-\hbar^2}{2m} \frac{\partial^2 \psi(x)}{\partial x^2} + V(x)\psi = i\hbar \frac{\partial}{\partial t} \psi \quad (34)$$

which is the famous time dependent Schrodinger wave equation. It is setting up and solving this equation, then analyzing the physical contents of its solutions that form the basis of that branch of quantum mechanics known as wave mechanics. Even though this equation does not look like the familiar wave equation that describes, for instance, waves on a stretched string, it is nevertheless referred to as a 'wave equation' as it can have solutions that represent waves propagating through space. We have seen an example of this: the harmonic wave function for a free particle of energy  $E$  and momentum  $p$ , i.e. is a solution of this equation with, as appropriate for a free particle,  $V(x) = 0$ . But this equation can have distinctly non-wave like solutions whose form depends, amongst other things, on the nature of the potential  $V(x)$  experienced by the particle.

$$\psi(x,t) = Ae^{i(px-Et)/\hbar}$$

In general, the solutions to the time dependent Schrodinger equation will describe the *dynamical* behaviour of the particle, in some sense similar to the way that Newton's equation  $F = ma$  describes the dynamics of a particle in classical physics. However, there is an important difference. By solving Newton's equation we can determine the position of a particle as a function of time, whereas by solving Schrodinger's equation, what we get is a wave function  $\Psi(x, t)$  which tells us (after we square the wave function) how the *probability* of finding the particle in some region in space varies as a function of time.

**PARTICLE IN AN INFINITE POTENTIAL BOX**

Consider a particle of mass 'm' confined to a one dimensional potential well of dimension 'L'. The potential energy,  $V = \infty$  at  $x=0$  and  $x=L$  and  $V = 0$  for  $0 \leq x \leq L$ . The walls are perfectly rigid and the probability of finding the particle is zero at the walls. Hence, the boundary conditions are,  $\Psi(x) = 0$  at  $x=0$  and  $x=L$ . The one dimensional time independent wave equation is:

$$\frac{\partial^2 \Psi(x)}{\partial x^2} + \frac{2m(E-V)}{\hbar^2} \Psi(x) = 0 \quad (35)$$

We can substitute  $V=0$  since the particle is free to move inside the potential well

$$\frac{\partial^2 \Psi(x)}{\partial x^2} + \frac{2mE}{\hbar^2} \Psi(x) = 0 \quad (36)$$

Let  $\frac{2mE}{\hbar^2} = k^2$  and the wave equation (36) can be written is:

$$\frac{\partial^2 \Psi(x)}{\partial x^2} + k^2 \Psi(x) = 0$$

The above equation represents simple harmonic motion and the general solution is  $\Psi(x)$

$$= A \sin kx + B \cos kx$$

Applying the condition  $\Psi(x) = 0$  at  $x = 0$ , we get  $0 = A.0 + B \Rightarrow B=0$

Applying the condition  $\Psi(x) = 0$  at  $x = L$ , we get  $0 = A \sin kL \Rightarrow k=(n\pi)/L$

*where  $n = 0,1,2,3... \text{ positive integer}$*

**Eigen values of energy :**

$$E_n = \frac{\hbar^2 k^2}{2m} = \frac{\hbar^2 (n\pi/L)^2}{2m} = \frac{8n^2\pi^2\hbar^2 m}{8mL^2} = \frac{8n^2\pi^2\hbar^2 m}{8mL^2} \quad (37)$$

'n' is the quantum number corresponding to a given energy level.  $n=1$  corresponds to the ground state,  $n=2$  corresponds to the first excited state and so on

**Eigen functions :**

The allowed wavefunctions are

$$\Psi_n(x) = A \sin (n\pi x/L) \quad (38)$$

The constant A can be evaluated from normalization condition  $x=L$

$$\int_{x=0} A^2 \sin^2(n\pi x/L) = 1$$

$$A = \sqrt{2/L} \tag{39}$$

hence, the eigen functions from(38) and (39) are

$$\psi_n(x) = \sqrt{2/L} \sin(n\pi x/L) \tag{40}$$

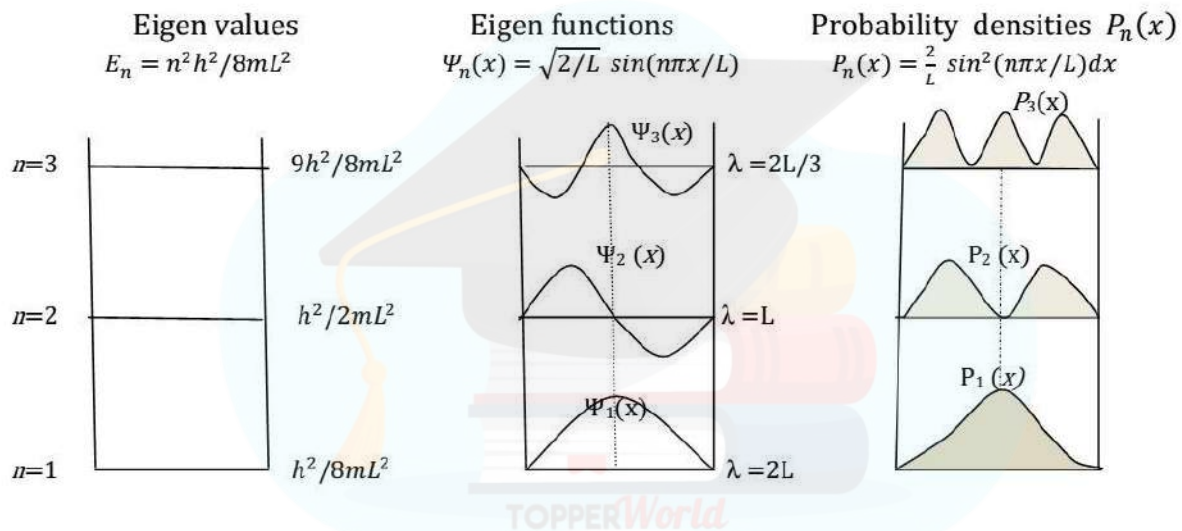

Graphical representation of  $E_n$ ,  $P_n(x)$  and  $\Psi_n(x)$  for  $n = 1, 2$  and  $3$  quantum states

**COMPTON EFFECT**

When X-rays are incident on a target rich in free electrons then the X-rays are scattered by these electrons. In this interaction the electron gains some kinetic energy and the X-ray photon loses some energy. This loss of energy results in the lowering of the wavelength of the incident X-rays. Hence, the scattered X-rays have

a lower wavelength as compared to the incident X-rays. The change in the wavelength of the incident X-rays is known as **Compton Shift** and this entire phenomena is called Compton Effect.

### DERIVATION

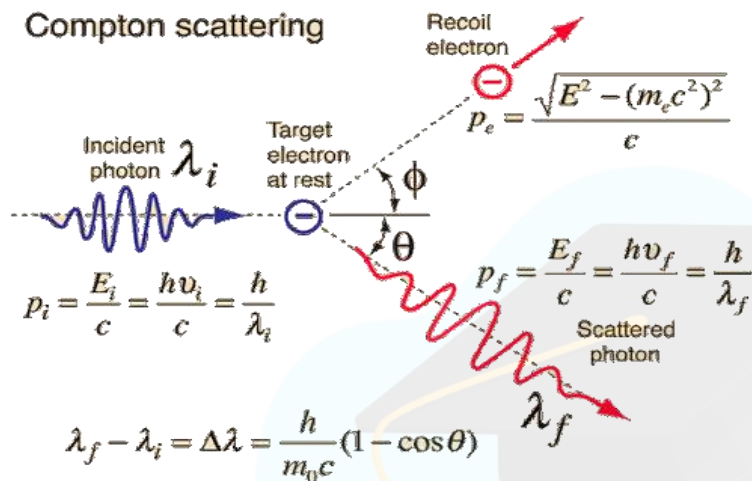

Consider a X-ray photon of energy,  $E_i = h\nu_i$  incident on an electron at rest. After the interaction the photon is scattered at an angle  $\phi$  and the electron recoils at an angle  $\theta$  w.r.t the direction of the incident photon. The scattered photon has energy,  $E_f = h\nu_f$ . The recoil electron gains kinetic energy and has total energy,  $E = E_{ef}$  and momentum  $p_e$ .

Using law of Conservation of Momentum in the direction parallel to the direction of incident photon

$$p_i + 0 = p_f \cos\theta + p_e \cos\phi$$

$$p_i - p_f \cos\theta = p_e \cos\phi \quad \dots (41)$$

Using law of Conservation of Momentum in the direction perpendicular to the direction of incident photon

$$0 + 0 = p_f \sin\theta - p_e \sin\phi$$

$$p_f \sin\theta = p_e \sin\phi \quad \dots (42)$$

Squaring and adding eq(41) and (42) we get,

$$p_i^2 + p_f^2 \cos^2\theta - 2p_i p_f \cos\theta + p_f^2 \sin^2\theta = p_e^2 (\cos^2\phi + \sin^2\phi) \quad \dots(43)$$

Simplifying eq(43) we get

$$p_i^2 + p_f^2 - 2p_i p_f \cos\theta = p_e^2 \quad \dots(44)$$

Using law of Conservation of Energy

$$E_i + E_{ei} = E_f + E_{ef}$$

$$h\nu_i + m_0 c^2 = h\nu_f + E_{ef} \quad \dots(45)$$

Rearranging and squaring eq (45) we get

$$(\hbar\nu_i - \hbar\nu_f)^2 + m_0^2 c^4 + 2(\hbar\nu_i - \hbar\nu_f) m_0 c^2 = E_{ef}^2 \quad \dots(46)$$

We know that

$$E_{ef}^2 = p_e^2 c^2 + m_0^2 c^4 \quad \dots(47)$$

Putting (47) in (46) we get

$$(\hbar\nu_i - \hbar\nu_f)^2 + m_0^2 c^4 + 2(\hbar\nu_i - \hbar\nu_f) m_0 c^2 = p_e^2 c^2 + m_0^2 c^4$$

$$(\hbar\nu_i)^2 + (\hbar\nu_f)^2 - 2\hbar\nu_i \hbar\nu_f + 2(\hbar\nu_i - \hbar\nu_f) m_0 c^2 = p_e^2 c^2 \quad \dots(47a)$$

Putting (44) in (47a)

$$(\hbar v_i)^2 + (\hbar v_f)^2 - 2\hbar v_i \hbar v_f + 2(\hbar v_i - \hbar v_f) m_0 c^2 = (p_i^2 + p_f^2 - 2p_i p_f \cos \theta) c^2 \dots (48)$$

We know that

$$v_i = \frac{c}{\lambda_i} \quad v_f = \frac{c}{\lambda_f} \quad p_i = \frac{h}{\lambda_i} \quad p_f = \frac{h}{\lambda_f} \dots (49)$$

Putting the eq(49) in eq(48)

$$\left( \frac{hc}{\lambda_i} \right)^2 + \left( \frac{hc}{\lambda_f} \right)^2 - 2 \frac{hc}{\lambda_i} \frac{hc}{\lambda_f} + 2 \left( \frac{hc}{\lambda_i} - \frac{hc}{\lambda_f} \right) m_0 c^2 = \left( \frac{hc}{\lambda_i} \right)^2 + \left( \frac{hc}{\lambda_f} \right)^2 - 2 \frac{hc}{\lambda_i} \frac{hc}{\lambda_f} \cos \theta$$

$$-2 \frac{hc}{\lambda_i \lambda_f} + 2 \frac{hc(1 - 1)}{\lambda_i \lambda_f} = -c^2 \frac{2hh}{\lambda_i \lambda_f} \cos \theta$$

$$- \frac{h}{\lambda_i} + \frac{h}{\lambda_f} = - \frac{hc \cos \theta}{\lambda_i \lambda_f}$$

$$\frac{h}{\lambda_i} (1 - \cos \theta) = c (1 - \cos \theta) m_0 \lambda_i \lambda_f$$



$$\frac{h}{m_0 c} (\lambda_f - \lambda_i) (1 - \cos \theta) = \frac{h}{m_0 c} (\lambda_f - \lambda_i)$$

$$\lambda_f - \lambda_i = \frac{h}{m_0 c} (1 - \cos \theta) \quad (50)$$

Compton Shift i.e. Change in wavelength  $\Delta\lambda = \lambda_f - \lambda_i = \frac{h}{m_0 c} (1 - \cos \theta)$

### Maximum Compton Shift

In eq(50) if  $\theta = 180^\circ$  then

$$\Delta\lambda = \frac{h}{m_0 c} (1 - (-1)) = \frac{2h}{m_0 c} = \frac{2 \times 6.63 \times 10^{-34}}{9.1 \times 10^{-31} \times 3 \times 10^8} = 0.0485 \text{ \AA} \quad (51)$$

### Presence of Unmodified Radiation at non-zero scattering angles

At times it happens that the X-ray photon interacts with bound electrons rather than with loosely held outer shell electrons. In this case the photon does not have enough energy to knock out the tightly bound electron, therefore the whole atom absorbs the energy transferred by the photon and then re-emits a photon of the same energy but in a different direction. Hence, we see a scattered photon having the same energy as that of the incident photon but travelling in a different direction. Mathematically this means that in the equation for Compton Shift the mass of the electron  $m_0$  should be replaced by the mass of the atom  $M_0$  i.e.

$$\Delta \lambda = \lambda_f - \lambda_i = \frac{h}{m_0 c} (1 - \cos \theta) \quad (52)$$

$m_0 c$

For example in case of Aluminium whose mass number is 27,  $M_0 = 27 \times 1836 m_0$

Maximum Compton shift will be

$$\Delta \lambda = \frac{2h}{27 \times 1836 m_0 c} = \frac{0.0485 \text{ \AA}}{27 \times 1836} = 9.8 \times 10^{-17} \text{ m} \quad \text{which is negligible.}$$

### Kinetic Energy of recoil electron

The amount of energy lost by the photon equals the kinetic energy gained by the electron.

$$\text{K.E of recoil electron} = h \nu_i - h \nu_f \quad (53)$$

$$\text{K.E of recoil electron} = \frac{hc}{\lambda_i} - \frac{hc}{\lambda_f}$$

$$= \frac{hc(\lambda_f - \lambda_i)}{\lambda_f \lambda_i}$$

From (50)

$$= \frac{hc}{m_0 c} \frac{h(1 - \cos \theta)}{\lambda_f \lambda_i}$$

$$= \frac{h^2(1 - \cos\theta)}{m_0\lambda_f \lambda} \quad (54)$$

### Absence of Compton Scattering in the visible range of electromagnetic radiation

The wavelength of visible light lies between 3800 Å - 7400 Å and the maximum compton shift is 0.0485 Å . Therefore, as compared to the visible range this shift is negligible. Hence, if visible light is scattered from an electron-rich target the wavelength of the scattered light is the same as that of the incident.

#### For Your Information

If a photon of wavelength 3800 Å is scattered by a free electron, then a maximum compton shift of 0.0485 Å can occur. If we calculate then we see that 0.0485 Å is just **0.001 % of 3800 Å** and such a small change can be neglected.

Whereas in the case of X-rays whose range lies between (0.1 Å - 10 Å) a change of 0.0485 Å is significant. For example 0.0485 is **48.5 % of 0.1 Å** and 0.485% of 10 Å and hence will be prominently observed.





## INTERFERENCE

### 4.1 Coherent Sources

It is found that it is not possible to show interference due to two independent sources of light because a large number of difficulties are involved. Two sources may emit light wave of different amplitude and wavelength and the phase difference between the two may change with time. The fundamental requirement to get well defined interference pattern is that the phase difference between the two waves should be constant. **The two sources are said to be coherent if they emit light waves of same frequency nearly the same amplitude and are always in phase with each other.**

There are two type of coherence

1. **Temporal coherence (Coherence in time):** Longitudinal coherence is also known as temporal coherence. It is a measure of phase relation of a wave reaching at given points at two different times. Example- In Michelson-Morley experiment waves reaching at a given point at the same time.
2. **Spatial coherence (Coherence in space):** Transverse coherence or lateral coherence is also known as spatial coherence. It is a measure of phase relation between the waves reaching at two different points in space at same time. Example- In Young double slit experiment waves reaching at two different points in space at the same time.

In actual practice it is not possible to have two independent sources which are coherent. But for experimental purpose two virtual sources formed from a single source can act as coherent sources. A coherent source forms sustained interference patterns when superimposition of waves occur and the positions of maxima and minima are fixed.

**Methods for producing interference pattern:** It is divided in following two classes for obtaining interference

**Division of wave front:** interference of light take place between waves from two sources formed due to single source. Example – interference by Young double slit.

**Division of amplitude :** interference takes place between the waves from the real source and virtual source. Example – interference by thin film

### 4.2 Interference in thin film

- An optical medium of thickness in the range of  $0.5 \mu m$  to  $10 \mu m$  may be considered as thin film.
- Interference can take place in a thin film by
  - i) Interference due to reflected light
  - ii) Interference due to transmitted light

### 4.3 Interference in a Thin Film Due to Reflected Light

Consider a ray SA of monochromatic light of wavelength  $\lambda$  be incident on the upper surface of a thin transparent film of uniform thickness  $t$  as shown in the fig. The ray SA is partly reflected along AB and partly refracted along AC at an angle  $r$ . The refracted ray AC is reflected from point C on the lower surface of the film along CD and finally emerges out along DE. To evaluate the path difference between AB & DE draw perpendiculars DL & CN on AB & DE respectively. As the paths of the rays AB & DE beyond DL are equal so the optical path difference between these two rays is given by

$$\Delta = \mu(AC+CD) - AL \quad \text{----- (1)}$$

In right angled triangle CNA we have  $\frac{CN}{AC} = \cos r$  or

$$AC = \frac{CN}{\cos r} = \frac{t}{\cos r} \quad \text{----- (2)}$$

$\angle ACN = r$  and  $CN = t$  similarly in another right-angled triangle

CND

we have  $\frac{CN}{CD} = \cos r$  or  $CD = \frac{CN}{\cos r} = \frac{t}{\cos r}$  ---- (3)

where  $\angle NCD = r$

In right angled triangle ADL  $\sin i = \frac{AL}{AD}$  or  $AL = AD \sin i = (AN+ND) \sin i$  ----- (4)

Again in triangles CNA & CND  $\frac{AN}{NC} = \tan r$  and  $\frac{ND}{NC} = \tan r$

$$AN = NC \tan r \text{ and } ND = NC \tan r$$

$$AN = t \tan r \text{ and } ND = t \tan r$$

From equation (4)  $AL = 2t \tan r (\sin i)$

$$AL = 2t \tan r (\mu \sin r) \quad \text{[from Snell's Law]}$$

$$AL = 2 \mu t \frac{\sin^2 r}{\cos r} \quad \text{----- (5)}$$

Substituting the values in equation (1)

$$\Delta = \mu \left( \frac{t}{\cos r} + \frac{t}{\cos r} \right) - 2 \mu t \frac{\sin^2 r}{\cos r}$$

$$\text{Hence, } \Delta = 2 \mu t \cos r \quad \text{----- (6)}$$

As the ray AB is reflected from the denser medium therefore there occurs an additional path difference of  $\lambda/2$  or a phase change of  $\pi$  between AB and DE.

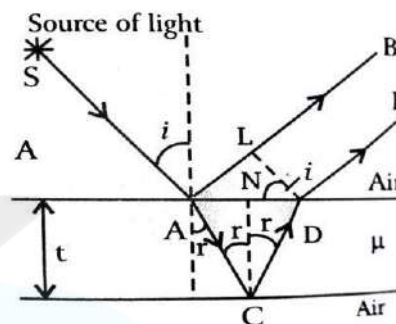

Total Path difference  $\Delta = 2 \mu t \cos r - \lambda/2$  ----- (7)

This is the actual path difference produced between interfering reflected rays AB and DE.

**Condition for constructive interference and destructive interference**  
**Constructive interference (Condition of Maxima):**

In the case of maxima, the path difference will be even multiple of  $\lambda/2$  i.e

$$2 \mu t \cos r - \lambda/2 = 2n(\lambda/2)$$

$$2 \mu t \cos r - \lambda/2 = n \lambda$$

$$2 \mu t \cos r = (2n + 1) \lambda / 2 \quad \text{where } n = 0, 1, 2, \dots$$

This is the condition for constructive interference and the film will appear bright.

**Destructive interference (Condition of Minima):**

In the case of maxima, the path difference will be odd multiple of  $\lambda/2$  i.e

$$2 \mu t \cos r - \lambda/2 = (2n + 1) \lambda / 2$$

$$2 \mu t \cos r = n \lambda \quad n = 1, 2, 3, \dots$$

This is the condition for destructive interference and the film will appear dark.

**4.4 Interference in a Thin Film Due to Transmitted Light**

Let a ray of light of wavelength  $\lambda$  be incident on the upper surface of a thin transparent film of uniform thickness  $t$  and refractive index  $\mu$  at an angle  $i$  as shown in fig. The ray SA is refracted along AB at an angle  $r$ . The refracted part AB is partly reflected along BC and partly refracted along BP at an angle  $i$ . The reflected part BC is again reflected from point C on the upper surface of the film along CD and finally emerges out along DQ, which are derived from the same incident ray and hence are coherent. To evaluate the path difference between BP & DQ the perpendiculars DN & CM are drawn on BP & BD respectively.

$$\Delta = \mu(BC+CD) - BN \quad \text{--- (1)}$$

In right angled triangle CBM we have  $\frac{MC}{BC} = \cos r$  or  
 $BC = \frac{CN}{\cos r} = \frac{t}{\cos r}$  ----(2)

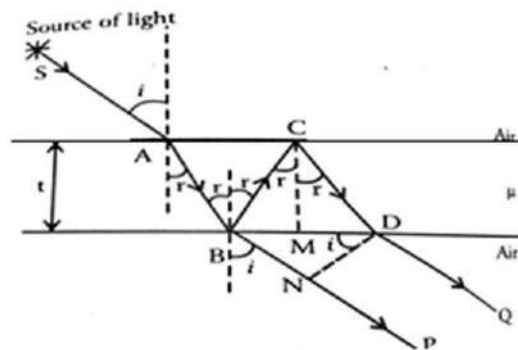



**Module-4-Wave Optics****CO4**

$\angle BCM = r$  and  $MC = t$  similarly, in another right-angled triangle  $MDC$  we have  $\frac{MC}{CD} = \cos r$  or  
 $CD = \frac{CN}{\cos r} = \frac{t}{\cos r}$  --- (3) where  $\angle MCD = r$

In right angled triangle  $BND$   $\sin i = \frac{BN}{BD}$  or  $BN = BD \sin i = (BM+MD) \sin i$  ---- (4)

Again, in triangles  $BMC$  &  $CDM$   $\frac{BM}{CM} = \tan r$  and  $\frac{MD}{CM} = \tan r$

$$BM = CM \tan r \text{ and } MD = CM \tan r$$

$$BM = t \tan r \text{ and } MD = t \tan r$$

From equation (4)  $BN = 2t \tan r (\sin i)$

$$BN = 2t \tan r (\mu \sin r) \quad [\text{from Snell's Law}]$$

$$BN = 2 \mu t \frac{\sin^2 r}{\cos r} \quad \text{---- (5)}$$

Substituting the values in equation (1)

$$\Delta = \mu \left( \frac{t}{\cos r} + \frac{t}{\cos r} \right) - 2 \mu t \frac{\sin^2 r}{\cos r}$$

$$\Delta = 2 \mu t \cos r \quad \text{----- (6)}$$

This is the path difference produced between interfering refracted rays  $BP$  and  $DQ$ .

**Condition for constructive interference and destructive interference** **Constructive interference (Condition of Maxima):**

In the case of maxima, the path difference will be even multiple of  $\lambda/2$  i.e

$$2 \mu t \cos r = 2n(\lambda/2)$$

$$2 \mu t \cos r = n \lambda \quad \text{where } n = 0, 1, 2, \dots$$

This is the condition for constructive interference and the film will appear bright.

**Destructive interference (Condition of Minima):**

In the case of maxima, the path difference will be odd multiple of  $\lambda/2$  i.e

$$2 \mu t \cos r = (2n + 1) \lambda / 2$$

$$2 \mu t \cos r = (2n + 1) \lambda / 2 \quad n = 1, 2, 3, \dots$$

This is the condition for destructive interference and the film will appear dark. Hence the conditions of maxima and minima in transmitted light are just opposite to the reflected light.

**Colours of thin films:** When white light is incident on a thin film only few wavelengths will satisfy the condition of maxima and therefore corresponding colours will be seen in the pattern. For other wavelengths condition of minima is satisfied, and so corresponding colours will be missing in the pattern. The coloration of film varies with  $t$  and  $r$ . Therefore, if one varies either  $t$  or  $r$  a different set of colours will be observed. Since the condition for maxima and minima are opposite in case of reflected and transmitted pattern. So the colours found in two patterns will be complimentary to each other.

**4.5 Necessity of broad source or extended Source:** When point source is used only a small portion of the film can be seen through eye and as a result the whole interference pattern cannot be seen. But when a broad source is used rays of light are incident at different angles and reflected parallel beam reach the eye and whole beam and complete pattern is visible.

#### 4.6 Interference Due to non-uniform Thin film (Wedge shaped thin film)

The wedge-shaped film as shown in Figure 4.5. Let a ray from  $S$  is falling on the film and after deflections produce interference pattern. The path difference between  $PQ$  and  $EH$

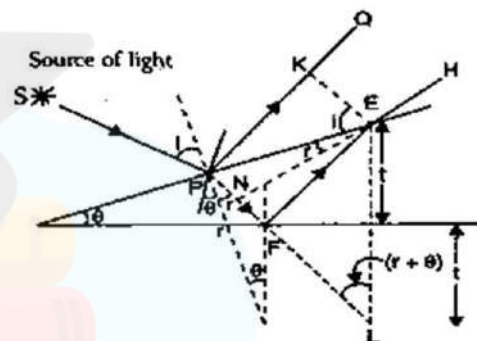

$$\Delta = [(PF + FE)_{\text{film}} - (PK)_{\text{air}}]$$

$$= \mu (PF + FE) - (PK)$$

$$= \mu (PN + NF + FE) - PK$$

$$= \mu (PN + NF + FE - PN)^*$$

$$= \mu (NF + FE)$$

$$\Delta = \mu (NF + FL) **$$

$$\Delta = \mu (NL)$$

$$\text{In Triangle ENL } \frac{NL}{EL} = \cos(r+\theta)$$

$$NL = EL \cos(r+\theta) = 2t \cos(r+\theta)$$

$$\text{Therefore } \Delta = 2 \mu t \cos(r+\theta)$$

Then total path difference considering refraction from denser medium is taking place

$$* \text{In triangle PKE } \sin i = \frac{PK}{PE}$$

$$\text{In triangle PNE, } \sin r = \frac{PN}{PE}$$

$$\frac{\sin i}{\sin r} = \mu \frac{PK}{PN} \cdot \frac{PE}{PE} = \mu, \text{ then } PK = \mu PN$$

\*\*In triangles EFR & FRL, FR is common,  $ER = RL = t$

$$\angle FER = \angle FLR = r + \theta$$

So both are congruent triangles therefore  $EF = FL$

$$\Delta = 2 \mu t \cos (r+\theta) - \lambda/2$$

*Condition for maxima*

$$2\mu \cos (r + \theta) = (2n + 1) \lambda/2 \quad \text{where } n = 0, 1, 2, \dots \dots$$

This is the condition for constructive interference and the film will appear bright. *Condition*

*for minima*

$$2\mu \cos (r + \theta) = n\lambda \quad \text{where } n = 0, 1, 2, \dots \dots$$

This is the condition for destructive interference and the film will appear dark.

### 4.7 Newton's Ring Experiment

**Newton's rings:** It is a special case of interference in a film of variable thickness such as that formed between a plane glass plate and a convex lens in contact with it. When monochromatic light falls over it normally we get a central dark spot surrounded by alternatively bright and dark circular rings. When white light is used the rings would be coloured.

**Experimental Arrangement:** Let S be the extended source of light, rays from which after passing through a lens L falls upon a glass plate G at  $45^\circ$ . After partial reflection these rays fall on a plano convex lens P placed on the glass plate E. The interference occurs between the rays reflected from the two surfaces of the air film and viewed through microscope M as shown Figure.

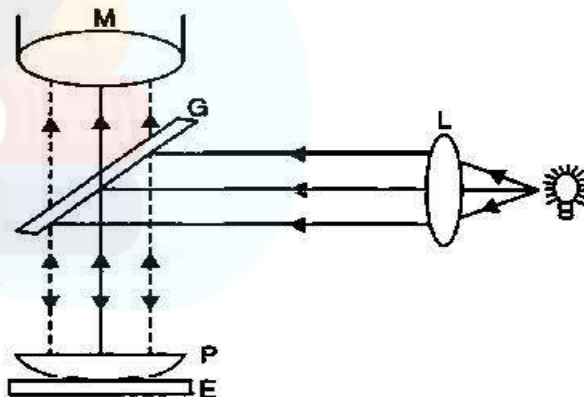

**Theory:** The air film formed is of wedge shape so the path difference produced will be

$$\Delta = 2 \mu t \cos (r+\theta) - \lambda/2,$$

For normal incident  $r = 0$  and  $\theta$  is very small because of large radius of curvature, So neglecting  $r$  and  $\theta$  the path difference will be

$$\text{So } \Delta = 2 \mu t - \lambda/2$$

At the point of contact  $t = 0$

So  $\Delta = \lambda/2$ , The central fringe will be dark.

**Module-4-Wave Optics****CO4****Condition for maxima :**

$$2 \mu t = (2n + 1) \lambda / 2 \quad \text{where } n = 0, 1, 2$$

This is the condition for constructive interference and the film will appear bright.

**Condition for minima:**

$$2 \mu t = n \lambda \quad \text{where } n = 0, 1, 2$$

This is the condition for constructive interference and the film will appear bright. we get alternatively bright and dark rings.

**Diameter of the rings:**

$$NP \times NQ = ND \times NO$$

$NP = NQ = r$ , radius of ring under consideration.

$$NO = t, ND = OD - ON, OD = 2R$$

$$\text{Then } r^2 = t(2R - t) = 2Rt - t^2 = 2Rt \quad t = r^2/2R$$

**Diameter of bright rings  $D_n$ :** From the condition of maxima put the value of  $t$  we get

$$\frac{2\mu r_n^2}{2R} = \frac{(2n+1)\lambda}{2}$$

$$r_n^2 = \frac{(2n+1)\lambda R}{2\mu} = \left(\frac{D_n}{2}\right)^2$$

$$D_n^2 = \frac{2(2n+1)\lambda R}{\mu}$$

$$D_n^2 = 2(2n + 1) \lambda R \quad (\text{For air, } \mu = 1)$$

$$D_n = \sqrt{(2\lambda R)} \sqrt{(2n + 1)}$$

$$D_n \propto \sqrt{(2n + 1)}$$

Thus, the diameter of bright rings are proportional to the square root of the odd natural numbers.

**Diameter of dark ring  $D_n$ :** Using the condition for minimum and put the value of  $t$

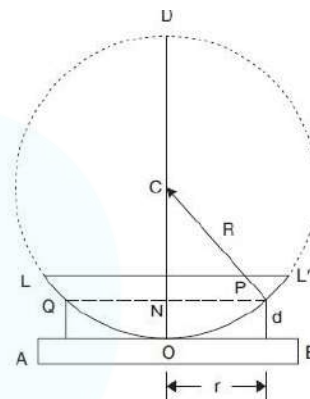

$$\frac{2\mu r_n^2}{2R} = n\lambda$$

which gives

$$(D_n)^2 = 4n\lambda R$$

$$\text{Or } D_n = \sqrt{4n\lambda R}$$

$$D_n \propto \sqrt{n}$$

Thus, the diameter of dark rings are proportional to the square root of natural numbers.

## 4.8 Application of Newton's Ring

### 4.8.1 Measurement of Wavelength of sodium light by Newton's Rings

For dark rings we know that

$$D_n^2 = 4n\lambda R$$

To avoid any mistake one can consider two clear fringes  $n^{\text{th}}$  and  $(n + p)^{\text{th}}$

$$\text{So, } (D_n)^2 = 4n\lambda R \quad \text{-----(1)}$$

$$(D_{n+p})^2 = 4(n+p)\lambda R \quad \text{-----(2)}$$

Subtracting these two equation we get  $((D_{n+p})^2 - (D_n)^2) = 4p\lambda R$

$$\text{Or } \lambda = \frac{(D_{n+p})^2 - (D_n)^2}{4pR}$$

Wavelength can be calculated if you know diameters of the rings, order of the ring and radius of curvature (R)

### 4.8.2 Measurement of Refractive Index of Liquid by Newton's Rings

For this purpose liquid film is formed between the lens and glass plate.

$$\text{For dark rings we know that } D_n^2 = \frac{4n\lambda R}{\mu}$$

To avoid any mistake one can consider two clear fringes  $n^{\text{th}}$  and  $(n + p)^{\text{th}}$

**Module-4-Wave Optics****CO4**

So,  $(D_n)^2 = \frac{4n\lambda R}{\mu}$  and  $(D_{n+p})^2 = \frac{4(n+p)\lambda R}{\mu}$

Subtracting these two we get  $[(D_{n+p})^2 - (D_n)^2]_{\text{liquid}} = \frac{4p\lambda R}{\mu}$  -----(1)

For air  $\mu=1$ , equation (1) can be written as  $[(D_{n+p})^2 - (D_n)^2]_{\text{air}} = 4p\lambda R$  -----(2)

Divide equation (2) by equation (1)

$$\mu = \frac{[(D_{n+p})^2 - (D_n)^2]_{\text{air}}}{[(D_{n+p})^2 - (D_n)^2]_{\text{liquid}}}$$

One can see that rings contract with the introduction of liquid.



## DIFFRACTION

The phenomenon of **bending of light round the corners** of an obstacle and their spreading into the geometrical shadow (of an object) is called **diffraction** and the distribution of light intensity resulting in dark and bright fringes (that is, with alternate maxima and minima) is called a **diffraction pattern**.

This phenomenon was first discovered in 1665 by an Italian scientist named **Grimaldi** and was studied by **Newton**. **Fresnel** was able to explain successfully the phenomenon of diffraction by considering that the diffraction phenomenon is caused by the interference of innumerable secondary wavelets produced by the unobstructed portions of the same wave front.

The diffraction phenomenon is usually divided into two categories:

- (i) **Fresnel's diffraction:** In this class either the source of light or screen or both are in general at a finite distance from the diffracting element but no lenses are needed for rendering the rays parallel or convergent. Therefore the incident wave front is either spherical or cylindrical instead of being plane.
- (ii) **Fraunhofer's diffraction:** In this class both the source and the screen are effectively at infinite distance from the diffracting element. It is observed by employing two convergent lenses: one to render the incoming light parallel and the other to focus the parallel diffracted rays on the screen. Therefore the incident wave front is plane.

### 4.9 Fraunhofer diffraction at a single Slit

Let S is a source of monochromatic light of wavelength ' $\lambda$ ', L is collimating lens AB is a slit of width a, L' is another converging lens and XY is the screen. light coming out from source and passing through slit is focused at the screen. A diffraction pattern is obtained on the screen which consists of central bright band having alternate dark and bright bands of decreasing intensity on both the sides. The complete arrangement is shown in Figure.

**Analysis and Explanation:** According to Huygen's theory a point in AB send out secondary waves in all directions. The diffracted ray along the direction of incident ray is focussed at C and those at an angle  $\theta$  are focused at P and P'. Being at equidistant from all slits points, secondary wave will reach in same phase at point C and so the intensity will be maximum there. For the intensity at P, let AN is normal to BN, then path difference between the rays emanating from extreme points A and B of the slit AB is given by

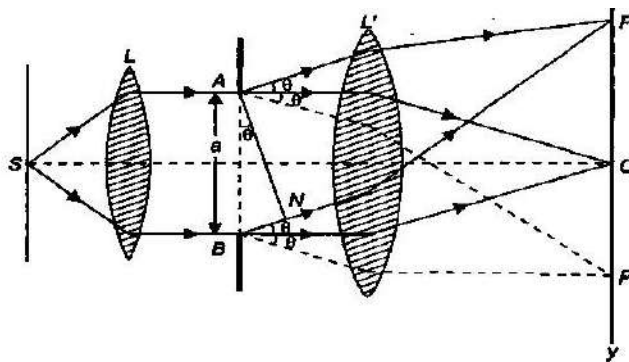

Module-4-Wave Optics

CO4

$$\Delta = BN = AN \sin \theta = a \sin \theta$$

$$\frac{2\pi}{\lambda}$$

Corresponding phase difference is  $\frac{2\pi}{\lambda} a \sin \theta$

which is zero for the ray from A and maximum for the ray from B. Let AB consists of n secondary sources then the phase difference between any two consecutive source will be

$$\frac{2\pi}{\lambda} a \sin \theta = \delta \text{ (say)}$$

$$n \delta$$

According to the theory of composition of n simple harmonic motions of equal amplitude (a) and common phase difference between successive vibrations, the resultant amplitude at P is given by

$$R = a \frac{\sin \frac{n\delta}{2}}{\sin \frac{\delta}{2}} = a \frac{\sin \left[ \frac{n \cdot \frac{2\pi}{\lambda} a \sin \theta}{2} \right]}{\sin \left[ \frac{\frac{2\pi}{\lambda} a \sin \theta}{2} \right]}$$

$$R = a \frac{\sin \frac{n\alpha}{2}}{\sin \frac{\alpha}{2}}$$

Where  $\alpha = \frac{2\pi a \sin \theta}{\lambda}$

sin

$$R = na \frac{\sin \frac{\alpha}{2}}{\frac{\alpha}{2}}$$

$$A \sin \frac{\alpha}{2}$$

Where A= nα

$$R = \frac{A \sin \frac{\alpha}{2}}{\frac{\alpha}{2}} \quad (1)$$

The resultant intensity at P, which is the square of the resultant amplitude R, is given by

$$I = R^2 = A^2 \frac{\sin^2 \frac{\alpha}{2}}{\frac{\alpha^2}{4}} \quad (2)$$



## Condition of Maxima and Minima

## Principal Maximum(central maxima)

The resultant amplitude given by equation (1) can be expanded as

$$A \sin \alpha = A \left[ \alpha - \frac{\alpha^3}{6} + \frac{\alpha^5}{120} - \dots \right]$$

$$R = A \left[ \alpha - \frac{\alpha^3}{6} + \frac{\alpha^5}{120} - \dots \right]$$

R will be maximum if the negative term vanish. This is possible only when  $\alpha = \pi a \sin \theta / \lambda = 0$  or  $\theta = 0$ . Thus the maximum value of resultant amplitude R at C is A and the corresponding maximum intensity is proportional to  $A^2$ .

## Positions of Minima

From equation (2) it is clear that the intensity is minimum when  $\sin \alpha = 0$

$$\sin \alpha = 0 = \sin n\pi$$

$$\alpha = \pi, 2\pi, 3\pi, \dots, n\pi,$$

$$\alpha \sin \alpha$$

$$\alpha \left[ \frac{\alpha \cos \alpha - \sin \alpha}{\alpha^2} \right]$$

$$\alpha$$

$$a \sin \alpha = n\lambda$$

Where  $n=1,2,3,\dots$  gives the directions of first, second, third,..... minima.

## Secondary Maxima

from equation (2) secondary maxima will be,

$$\text{when } \frac{dI}{d\alpha} = 0 \Rightarrow \frac{dI}{d\alpha} [A^2 \sin^2 \alpha / \alpha^2] = 0$$

$$A^2 \frac{2 \sin \alpha}{\alpha} \frac{(\alpha \cos \alpha - \sin \alpha)}{\alpha^2} = 0$$

$$\text{i.e either } \sin \alpha = 0 \text{ or } (\alpha \cos \alpha - \sin \alpha) = 0$$

the equation  $\sin \alpha = 0$  gives the value of  $\alpha$  (except  $\alpha = 0$ , which is central maxima) for which the intensity is zero on the screen. Hence position of secondary maxima are given by the roots of the equation

$$\alpha \cos \alpha - \sin \alpha \text{ or } \alpha = \tan \alpha$$

The value of  $\alpha$  satisfying the above equation are obtained graphically by plotting the curves

$$y = \alpha \text{ and } y = \tan \alpha \text{ on the same graph}$$

The point of intersection of two curves give the value of  $\alpha$  which satisfy the above equation =  $\tan \alpha$ .

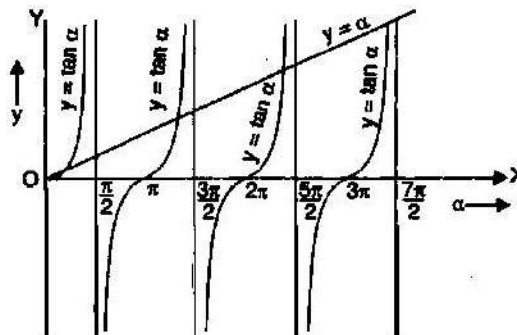

The point of intersection will give  $\alpha = 0, \pm 3\pi/2, \pm 5\pi/2, \pm 7\pi/2$

$$\pi/2, \alpha=0, \pm 1.43 \pi, \pm 2.462 \pi, \pm 3.471 \pi,$$

The first value  $\alpha = 0$  correspond point to central maximum. The remaining value of  $\alpha$  gives secondary maxima.  $\alpha = \pm 3\pi/2, \pm 5\pi/2, \pm 7\pi/2, \dots$

$$\alpha = \frac{\pm(2n+1)\pi}{2} \text{ where } n=1, 2, 3, \dots$$

#### Intensity Distribution:

**a) Intensity of Central Maxima:** at,  $\alpha = 0$

$$I = I_0 \left[ \frac{\sin \alpha}{\alpha} \right]^2 = I_0 = I_0$$

**b) Intensity of First Secondary Maxima:** for first( $n=1$ ) secondary maxima,  $\alpha = 3\pi/2$ . Then equation (2) will be

$$I_1 = I_0 \left( \frac{\sin 3\pi/2}{3\pi/2} \right)^2 = \frac{4}{9\pi^2} I_0 = \frac{1}{22} I_0$$

$$\frac{I_1}{I_0} = \frac{4}{9\pi^2} = \frac{1}{22} = 4.5\%$$

**c) Intensity of second Secondary Maxima:** for second( $n=1$ ) secondary maxima,  $\alpha = 5\pi/2$ . Then equation (2) will be

$$I_2 = I_0 \left( \frac{\sin 5\pi/2}{5\pi/2} \right)^2 = \frac{4}{25\pi^2} I_0 = \frac{1}{62} I_0$$

$$\frac{I_2}{I_0} = \frac{4}{25\pi^2} = \frac{1}{62} = 1.61\%$$

The diffraction pattern consists of a bright central maximum surrounded by minima and the intensity of secondary maxima goes on decreasing very rapidly.

### 4.10 Fraunhofer's diffraction at a double slit

Let us suppose two parallel slits AB and DE each of width 'a' and separated by opaque distance 'b'. Let a plane wave front of monochromatic light of wavelength λ be incident normally upon the slits. Suppose the light diffracted by the slits be focused by a convex lens L on the screen XY situated in the focal plane of the lens. The diffraction pattern obtained on the screen is characterized by a number of equally spaced interference maxima and minima in the region normally occupied by the central maximum in the single slit diffraction.

**Explanation:** According to the theory of diffraction at a single slit, the resultant amplitude due to all the wavelets from each slit is given by

$$R \propto \frac{A \sin \alpha}{\alpha}, \quad \dots\dots\dots (1)$$

where  $\alpha = \pi a \sin \theta / \lambda$  ..... (2)

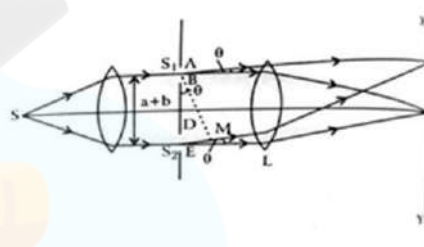

We can replace all secondary waves from the slit AB by a single wave of amplitude R and phase α originating from its middle point S<sub>1</sub>. Similarly all the secondary wavelets in the second slit DE can also be replaced by the similar wave originating from its middle point S<sub>2</sub>. Hence the resultant amplitude at a point P on the screen will be due to the interference between the two waves of same amplitude R and a phase difference φ originating from S<sub>1</sub> and S<sub>2</sub>.

Let us drop a perpendicular S<sub>1</sub>M on S<sub>2</sub>M. The path difference between the two wave originating from S<sub>1</sub> and S<sub>2</sub> and reaching at P after travelling in the direction θ will be

$$S_2M = (a+b) \sin \theta \quad \dots\dots\dots (3)$$

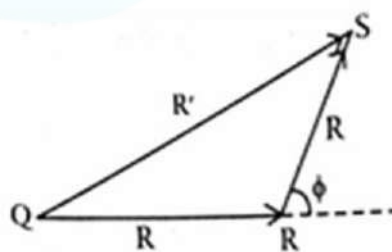

Therefore the corresponding phase difference between them is

$$\phi = \frac{2\pi}{\lambda} (a+b) \sin \theta \quad \dots\dots\dots (4)$$

Module-4-Wave Optics

CO4

The resultant amplitude at P can be obtained by the vector amplitude diagram QR and RS represent the amplitude of the two waves originating from S<sub>1</sub> and S<sub>2</sub> and angle φ as phase difference between them

$$OS^2 = QR^2 + RS^2 - 2(QR)(RS)\cos\phi$$

$$R^2 = R^2 + R^2 - 2R.R.\cos\phi$$

$$\Rightarrow 2R^2(1 - \cos\phi) \dots\dots\dots (5)$$

$$\Rightarrow 4R^2 \cos^2 \frac{\phi}{2}$$

Substituting the values of R and φ from equations (1) and (4) in equation (5), we get

$$R^2 = 4A^2 \frac{\sin^2 \frac{\phi}{2}}{\phi^2} \cos^2 \frac{\phi}{2} \dots\dots\dots (6)$$

$$\Rightarrow \frac{I}{I_0} = \left[ \frac{a - b \cos \phi}{2} \right]^2 \sin^2 \frac{\phi}{2} \dots\dots\dots (7)$$

Therefore, the resultant intensity at P is

$$I = R^2 = 4A^2 \frac{\sin^2 \frac{\phi}{2}}{\phi^2} \cos^2 \frac{\phi}{2} \dots\dots\dots (8)$$

This is the required expression for the intensity distribution due to a Fraunhofer's diffraction at a double slit.

It is clear from equation (8) that the resultant intensity at any point on the screen depends on two factors:

1.  $\frac{\sin^2 \frac{\phi}{2}}{\phi^2}$  which gives diffraction pattern due to each single slit
2.  $\cos^2 \frac{\phi}{2}$  which gives the interference pattern due to two waves of same amplitude (R) originating from the mid-points of their respective slits.

Hence the resultant intensity, due to double slit of equal width, at any point on the screen is given by

the product of  $\sin^2 \frac{\beta}{2}$  and  $\cos^2 \beta$ . If either of these factor is zero, the resultant intensity will also be zero. Let us now consider the effect of each factor.

(i) Principal maxima is given by  $A_2 \sin^2 \frac{\beta}{2}, \theta=0$

Position of minima are given by

$$\sin \alpha = 0, \quad \alpha \text{ is non-zero}$$

$$\alpha = m\pi, \quad m=1,2,3,\dots$$

$$a \sin \frac{\beta}{2} = m\lambda$$

$$\sin \frac{\beta}{2} = \frac{m\lambda}{a}, \quad m=1,2,3,\dots$$

Position of secondary maxima approach to

$$\frac{3\pi}{2}, \frac{5\pi}{2}, \frac{7\pi}{2}, \dots$$

(ii) According to interference term,  $\cos^2 \beta$ , I is maximum when  $\cos^2 \beta = 1$

$$\beta = n\pi, \quad n=0,1,2,3,\dots$$

$$\frac{a \sin \frac{\beta}{2}}{\lambda} = n, \quad n=0,1,2,3,\dots$$

$$a \sin \frac{\beta}{2} = n\lambda$$

Intensity is minimum when  $\cos^2 \beta = 0, \beta = (2n+1)\pi/2$

$$a \sin \alpha = (2n+1)\frac{\lambda}{2}$$

given by

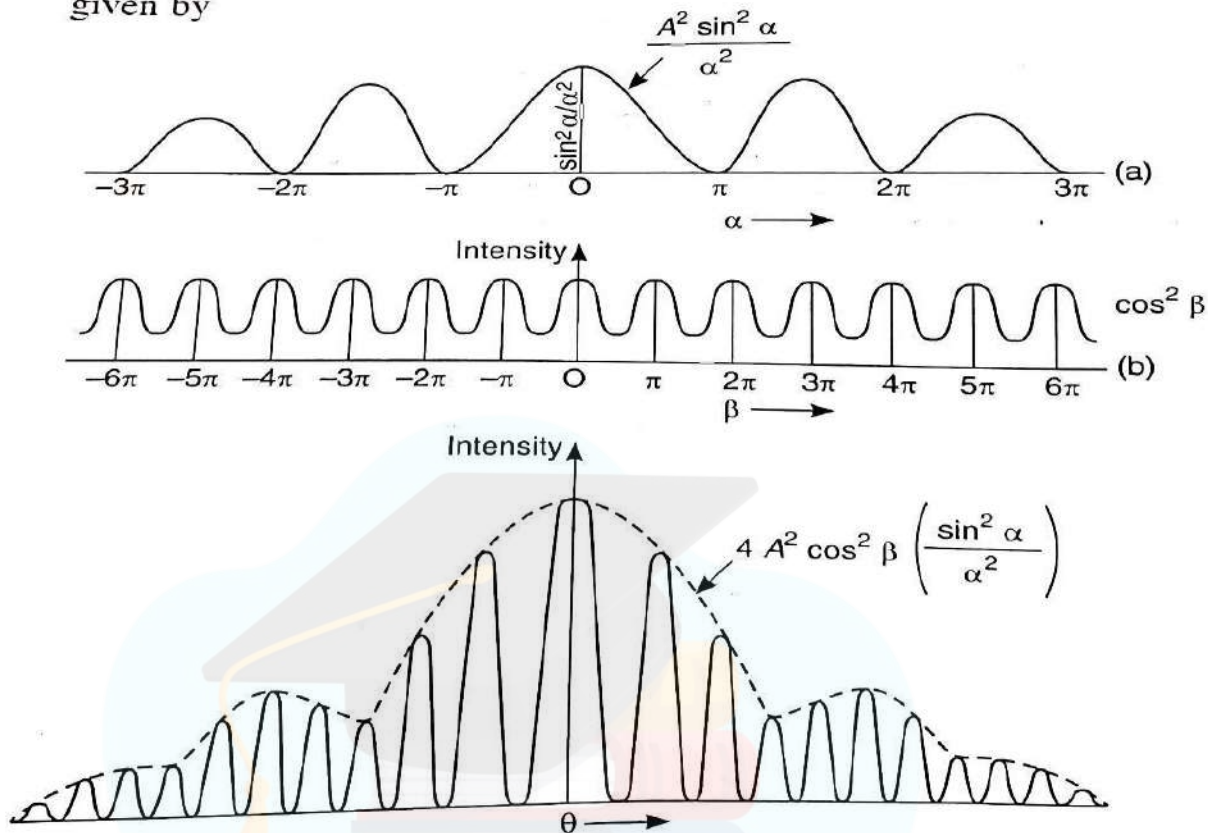

Thus, the entire pattern due to double slit may be considered as consisting of interference fringes due to light from both slits. The intensities of these fringes being governed by diffraction occurring at the individual slits.

### 4.11 Plane Transmission Diffraction Grating (N-Slits Diffraction/Diffraction due to double slits)

A plane diffraction grating is an arrangement consisting of a large number of close, parallel, straight, transparent and equidistant slits, each of equal width  $a$ , with neighbouring slits being separated by an opaque region of width  $b$ . A grating is made by drawing a series of very fine, equidistant and parallel lines on an optically plane glass plate by means of a fine diamond pen. The light cannot pass through the lines drawn by diamond; while the spacing between the lines is transparent to the light. There can be 15,000 lines per inch or more is such a grating to produce a diffraction of visible light. The spacing  $(a + b)$  between adjacent slits is called the diffraction element or grating element. If the lines are drawn on a silvered surface of the mirror (plane or concave) then light is reflected from the positions of mirrors in between any two lines and it forms a plane concave reflection grating. Since the

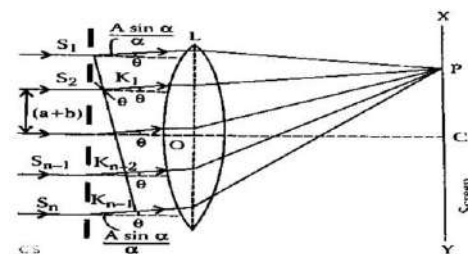

original gratings are quite expensive for practical purposes their photographic reproductions are generally used.

The commercial gratings are produced by taking the cast of an actual grating on a transparent film such as cellulose acetate. A thin layer of collodin solution (celluloid dissolved in a volatile solvent) is poured on the surface of ruled grating and allowed to dry. Thin colluding film is stripped off from grating surface. This film, which retains the impressions of the original grating, is preserved by mounting the film between two glass sheets. Now-a-days holographic gratings are also produced. Holographic gratings have a much large number of lines per cm than a ruled grating

**Theory of Grating:** Suppose a plane diffraction grating, consisting of large number of  $N$  parallel slits each of width  $a$  and separation  $b$ , is illuminated normally by a plane wave front of monochromatic light of wavelength  $\lambda$ . as shown in Figure . The light diffracted through  $N$  slits is focused by a convex lens on screen  $XY$  placed in the focal plane of the lens  $L$ . The diffraction pattern obtained on the screen with very large number of slit consists of extremely sharp principle interference maximum; while the intensity of secondary maxima becomes negligibly small so that these are not visible in the diffraction pattern. Thus, if we increase the number of slits ( $N$ ), the intensity of principal maxima increases.

### Explanation

According to Huygen's principle, all points within each slit become the source of secondary wavelets, which spread out in all directions. From the theory of Fraunhofer diffraction at a single slit, the resultant

$$A \sin \alpha$$

amplitude  $R$  due to all waves diffracted from each slit in the direction  $\theta$  is given by  $R \propto \frac{A \sin \alpha}{\alpha}$ , where  $A$

$\propto$  is a constant

and  $\alpha = \pi a \sin \theta / \lambda$ . Thus the resultant of all secondary waves may be treated as a single wave of amplitude  $R$  and phase  $\alpha$  starting from the middle point of each slit and travelling at an angle  $\theta$  with the normal. Thus the waves diffracted from all the  $N$  slits in direction  $\theta$  are equivalent to  $N$  parallel waves, each starting from the middle points  $S_1, S_2, S_3, \dots, S_{n-1}, S_n$  of slits. Draw perpendicular  $S_1K_{n-1}$  from  $S_1$  on  $S_nK_{n-1}$ , then the path difference between the waves originating from the slits  $S_1$  and  $S_2$  is  $S_2K_1 = S_1S_2 \sin \theta = (a+b) \sin \theta$

Similarly, between rays from  $S_2$  and  $S_3$  will be

$S_3K_2 = S_2S_3 \sin \theta = (a+b) \sin \theta$  Thus the path difference between the waves from any two consecutive slits is  $(a+b) \sin \theta$ . Therefore the corresponding phase difference is  $2\pi/\lambda(a+b) \sin \theta = 2\beta$ . Therefore as we pass from one vibration to another, the path goes on increasing by an amount  $(a+b) \sin \theta$  and corresponding phase goes on increasing by an amount  $2\pi/\lambda(a+b) \sin \theta$ . Thus phase increases in arithmetical progression. therefore the problem reduces to

Amplitude of N waves of equal amplitude  $R \sin \phi$  find the resultant amplitude of N waves of equal amplitude  $R \sin \phi$  and period but the phase  $\phi$  increasing in A.P. In this case the resultant amplitude in the direction  $\theta$  is given by

$$R \sin N\phi = R \sin \phi \frac{\sin N\phi}{\sin \phi}$$

The corresponding intensity at P is given by

$$I = A^2 \sin^2 \phi \frac{\sin^2 N\phi}{\sin^2 \phi} \dots \dots \dots (1)$$

$$I = R^2 \frac{\sin^2 N\phi}{\sin^2 \phi}$$

The first factor of equation (1), that is  $A^2 \sin^2 \phi$  represents intensity distribution due to diffraction at a single slit, whereas the second factor,  $\frac{\sin^2 N\phi}{\sin^2 \phi}$  gives the distribution of intensity in the diffraction pattern due to the interference in the waves from all the N slits.

**Principal maxima:**

The condition for principal maxima is  $\sin \beta = 0$ , i.e.,  $\beta = \pm$

$$n\pi, \text{ where } n = 0, 1, 2, 3, \dots \cdot \pi/\lambda \Rightarrow (a + b) \sin \theta = \pm n\pi \Rightarrow (a + b) \sin \theta = \pm$$

$$n \lambda \dots (1)$$

If we put  $n = 0$  in equation (1), we get  $\theta = 0$  and equation (1) gives the direction of zero order principal maximum. The first, second, third, ... order principal maxima may be obtained by putting  $n = 1, 2, 3, \dots$  in equation (1).

**Minima:** The intensity is minimum, when



$\sin N\beta = 0$ ; but  $\sin \beta \neq 0$  Therefore

$$N\beta = \pm m\pi$$

$$N \pi/\lambda (a + b) \sin \theta = \pm m\pi$$

$$N (a + b) \sin \theta = \pm m\lambda \dots(2)$$

Here can have all integral values except 0, N, 2N, 3N, ... because for these values of m,  $\sin 13 = 0$  which gives the positions of principal maxima. Positive and negative signs show that the minima lie symmetrically on both sides of the central principal maximum. It is clear from equation (2) that for  $m = 0$ , we get zero order principal maximum,  $m = 1, 2, 3, 4, \dots, (N - 1)$  gives minima governed by equation (2) and then at  $m = N$ , we get principal maxima of first order. This indicates that, there are (N - 1) equispaced minima between zero and first orders maxima. Thus, there are (N - 1) minimum between two successive principal maxima.

**Secondary Maxima:** The above study reveals that there are (N - 1) minima between two successive principal maxima. Hence there are (N - 2) other maxima coming alternatively with the minima between two successive principal maxima. These maxima are called secondary maxima. To find the positions of the secondary maxima, we first differentiate equation with respect to  $\beta$  and equating to zero  $dI/d\beta = A^2 \sin^2 \alpha / \alpha^2 \cdot 2 [\sin N\beta / \sin \beta] N \cos N\beta \sin \beta - \sin N \cos \beta / \sin 2\beta = 0$   $N \cos N\beta \sin \beta = \sin N\beta \cos \beta = 0$   $\tan N\beta = N \tan \beta$

To find the intensity of secondary maximum, we make these of the triangle shown in Figure. We have  $\sin N\beta = N \tan \beta / \sqrt{1 + N^2 \tan^2 \beta}$

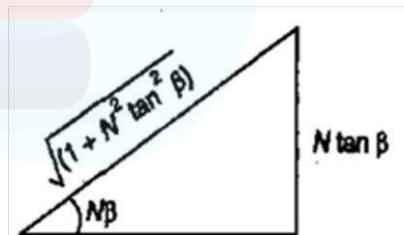

Therefore  $\sin^2 N\beta / \sin^2 \beta = (N^2 \tan^2 \beta / \sin^2 \beta (1 + N^2 \tan^2 \beta)) \sin$

$$^2 N\beta / \sin^2 \beta = (N^2 \tan^2 \beta (1 + N \tan^2) / \sin^2 \beta$$

$$= N^2 (1 + N^2 \sin^2 \beta)$$

Putting this value of  $\sin^2 N\beta / \sin^2 \beta$  we get

$$I_s = A^2 \sin^2 \alpha / \alpha^2 = N^2 / [1 + (N^2 - 1) \sin^2 \beta]$$

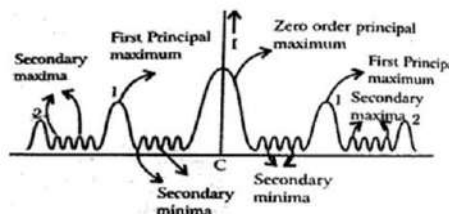

This indicates the intensity of secondary maxima is proportional to

$N^2 / [1 + (N^2 - 1) \sin^2 \beta]$ , whereas the intensity of principal maxima is proportional to  $N^2$ .

#### 4.12 Absent Spectra with a Diffraction Grating

It may be possible that while the first order spectra is clearly visible, second order may be not be visible at all and the third order may again be visible. It happen when for again angle of diffraction  $\theta$ , the path difference between the diffracted ray from the two extreme ends of one slit is equal to an integral multiple of  $\lambda$  if the path difference between the secondary waves from the corresponding point in the two halves will be  $\lambda/2$  and they will can all one another effect resulting is zero intensity. Thus the mining of single slit pattern are obtained in the direction given by.

$$a \sin \theta = m\lambda \quad \dots(1)$$

where  $m = 1, 2, 3, \dots$  excluding zero but the condition for  $n$ th order principles maximum in

$$\text{the grating spectrum is } (a + b) \sin \theta = n\lambda \quad \dots (2)$$

If the two conditions given by equation (2) are simultaneously satisfied then the direction in which the grating spectrum should give us a maximum every slit by itself will produce darkness in that direction and hence the most favourable phase for reinforcement will not be able to produce an illumination i.e., the resultant intensity will be zero and hence the absent spectrum. Therefore dividing equation (2) by equation (1)

$$(a + b) \sin \theta / a \sin \theta = n / m$$

$$(a + b) / a = n / m$$

This is the condition for the absent spectra in the diffraction pattern

If  $a = b$  i.e., the width of transparent portion is equal to the width of opaque portion then

from equation (3)  $n = 2m$  i.e., 2nd, 4th, 6th etc., orders of the spectra will be absent corresponds to the minima due to single slit given by  $m = 1, 2, 3$  etc.

$$b = 2a \text{ \& } n = 3m$$

i.e., 3rd, 6th, 9th etc., order of the spectra will be absent corresponding to a minima due to a single slit given by  $m = 1, 2, 3$  etc.

### 4.13 Number of Orders of Spectra with a Grating

The number of spectra that are visible in a given grating can be easily calculated with the help of the equation.

$$(a + b) \sin \theta = n \lambda \quad n = (a+b)$$

$$\sin \theta / \lambda$$

Here  $(a + b)$  is the grating element and is equal to  $1/N = 2.54 \text{ N cm}$ ,  $N$  being number of lines per inch in the grating. Maximum possible value of the angle of diffraction  $\theta$  is  $90^\circ$ , Therefore  $\sin \theta = 1$  and the maximum possible order of spectra.

$$N_{\max} = (a+b)/\lambda$$

If  $(a + b)$  is between  $\lambda$  and  $2\lambda$ . i.e., grating element  $(a + b) < 2\lambda$  then,

$n_{\max} < 2\lambda / \lambda < 2$  and hence only the first order of spectrum is seen.

### 4.14 Dispersive Power of a plane diffraction grating

The dispersive power of a diffraction grating is defined as the rate of change of the angle of diffraction with the change in the wavelength of light used.

Thus, if the wavelength changes from  $\lambda$  to  $(\lambda + d\lambda)$  and corresponding angle of diffraction changes from  $\theta$  to  $(\theta + d\theta)$ , then the ratio  $d\theta/d\lambda$  is called the dispersive power of the grating.

For plane diffraction grating, we have the grating equation for normal incidence as

$$(a + b) \sin \theta = n \lambda \quad \dots\dots\dots (10)$$

Where  $(a+b)$  is the grating element and  $\theta$  the angle of diffraction for  $n^{\text{th}}$  order spectrum.

$$d$$

Differentiating eqn. (1) with respect to  $\lambda$ , we get  $(a+b) \cos \theta \frac{d\theta}{d\lambda} = n$

Therefore, the dispersive power,

$$d \sin \theta = n \lambda \quad \dots \dots \dots (2) \quad d \sin \theta = a \sin \theta$$

$$a b \cos \theta$$

$$\frac{d \sin \theta}{d \sin \theta} = \frac{n \lambda}{a b \sin \theta} \sin \theta \left[ \frac{1}{2} \right]$$

$$\frac{1}{a b \sin \theta} = \frac{n \lambda}{a b \sin \theta} \left[ \frac{1}{2} \right]$$

$$\frac{d \sin \theta}{d \sin \theta} = \frac{1}{\sqrt{\frac{a^2 + b^2}{n^2} \sin^2 \theta}} \quad \square$$

In the above equation  $d \theta$  is the angular separation between two spectral lines with difference in wavelengths as  $d \lambda$ .

### 4.15 Resolving Power of Optical Instruments

When two objects are very close to each other, it may not be possible for our eye to see them separately. If we wish to see them separately, then we will have to make use of some optical instruments like microscope, telescope, grating, prism etc. The ability of an optical instrument to form distinctly separate images of two objects, very close to each other is called the resolving power of instrument. A lens system like microscope and telescope gives us a geometrical resolution while a grating or a prism gives a spectral resolution. In fact the image of a point object or line is not simply a point or line but what we get is a diffraction pattern of decreasing intensity. For a two point system two diffraction patterns are obtained which may and may not overlap depending upon their separation. The minimum separation between two objects that can be resolved by an optical instrument is called resolving limit of that instrument. The resolving power is inversely proportional to the resolving limit.

#### 4.15.1 Rayleigh Criterion of Resolution

According to Lord Rayleigh’s arbitrary criterion two nearby images are said to be resolved if (i) the position of central maximum of one coincides with the first minima of the other or vice versa.

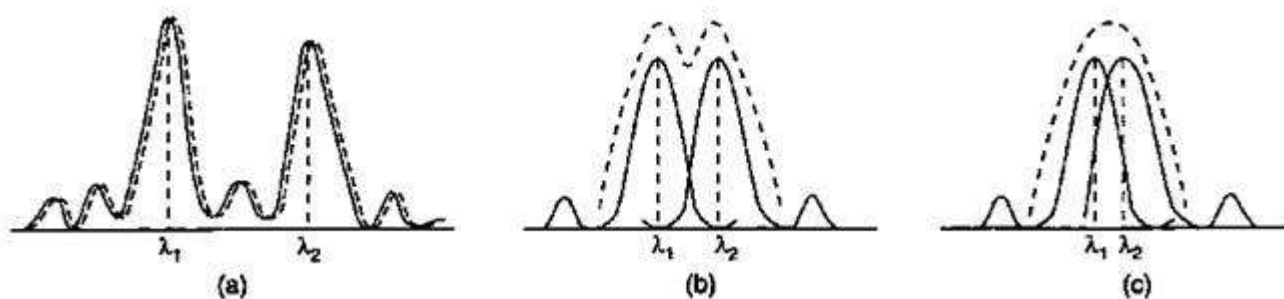

To illustrate this let us consider the diffraction patterns due to two wavelengths  $\lambda_1$  and  $\lambda_2$ . There may be three possibilities. First let the difference ( $\lambda_1 - \lambda_2$ ) is sufficiently large so that central maxima are quite separate, this situation is called well resolved. Secondly consider that ( $\lambda$ ) is such that central maximum due to one falls on the first minima of the other. The resultant intensity curve shows a distinct dip in the middle of two central maxima. This situation is called just resolved as the intensity of the dip can be resolved by our eyes.

$$I_{\text{dip}} = 0.81 I_{\text{max}} \quad \dots (1)$$

Thirdly let the ( $\lambda_1 - \lambda_2$ ) is very small such that they come still close as shown in Figure. The intensity curves have sufficient overlapping and two images cannot be distinguished separately. The resultant curve almost appears as one maxima. This case is known as unresolved. Thus the minimum limit of resolution is that when two patterns are just resolved.

#### 4.15.2 Resolving Power of Plane Diffraction Grating

We know that the diffraction grating has ability to produce spectrum i.e., to separate the lines of nearly equal wavelengths and therefore it has resolving capability. The resolving power of a grating may be defined as its ability to form separate diffraction maxima of two wavelengths which are very close to each other. If  $\lambda$  is the mean value of the two wavelengths and  $d\lambda$  is the difference between two then resolving power may be defined as resolving power =  $\lambda / d\lambda$

**Expression for resolving power:** Let a beam of light having two wavelengths  $\lambda_1$  and  $\lambda_2$  is falling normally on a grating AB which has  $(a + b)$  grating element and  $N$  number of slits as shown in Figure. After passing through grating rays form the diffraction patterns which can be seen through telescope. Now, if these patterns are very close together they overlap and cannot be seen separately. However, if they satisfy the Rayleigh criterion, that is the wavelengths can be just resolved when central maxima due to one falls on the first minima of the other.

Module-4-Wave Optics

CO4

Let the direction of nth principal maxima for wavelength  $\lambda_1$  is given by

$(a + b) \sin \theta_n = n\lambda_1$  Or  $N(a + b) \sin \theta_n = Nn\lambda_1$  and the first minima will be in the direction given by

$$N(a+b)\sin(\theta_n + d\theta_n) = m\lambda_1$$

where m is an integer except 0, N, 2N ... ,because at these values condition of maxima will be satisfied. The first minima adjacent to the nth maxima will be in the direction  $(\theta_n + d\theta_n)$  only when  $m = (nN + 1)$ . Thus

$$N(a + b) \sin(\theta_n + d\theta_n) = (nN + 1) \lambda_1$$

Therefore  $(a + b) \sin(\theta_n + d\theta_n) = n\lambda_2$  or  $N(a + b) \sin(\theta_n + d\theta_n) = Nn\lambda_2$

Now equating the two equations

$$(nN + 1) \lambda_1 = Nn \lambda_2 \quad \text{or} \quad (nN + 1) \lambda = Nn (\lambda + d\lambda)$$

$$\lambda = Nnd\lambda \quad \lambda_1 = \lambda, \lambda_2 - \lambda_1 = d\lambda, \lambda_2$$

$$= \lambda + d\lambda.$$

Thus resolving power of grating is found as

$$R.P. = \lambda/d\lambda = nN$$

Resolving power = order of spectrum x total number of lines on grating which can also be written as

$N(a + b) \sin \theta/\lambda = w \sin \theta_n/\lambda$  where,  $m = N(a + b)$  is the total width of lined space in grating.

$$R.P._{MAX} = N(a+b)/\lambda \quad \text{when } \theta_n = 90^\circ$$

**Relation between Resolving Power and Dispersive Power of a Grating**

We know that resolving power,  $R.P. = \lambda/d \lambda nN$  and dispersive power

$$D.p. = d\theta / D \lambda = n / (a+b) \cos \theta_n$$

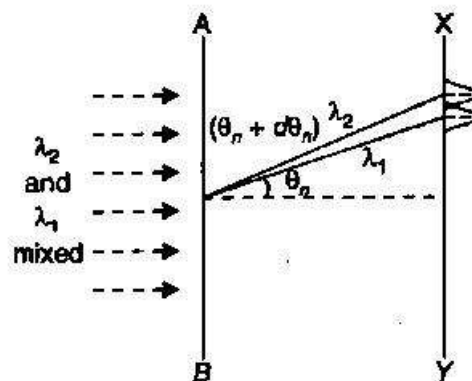

**Module-4-Wave Optics****CO4**

Therefore,  $\lambda/d \lambda = nN = N(a+b) \cos \theta_n / (a+b) \cos \theta_n \lambda$

$$d \lambda = A x d \theta / d \lambda$$

Resolving power = total aperture of telescope objective x dispersive power.

The resolving power of a grating can be increased by

- (i) Increasing the number of lines on the grating  $N$ .
- (ii) Increasing the sides of spectrum  $n$ .
- (iii) Increasing the total width of grating 'w', for which one has to make use of whole aperture of telescopes objective.





## 5.1 Introduction to fiber optics

An optical fiber is a hair thin cylindrical fiber made of glass or any transparent dielectric material. It is used for optical communication as a waveguide. It transmits signals in form of light. The optical fiber optical communication system is shown in Fig 5.1.

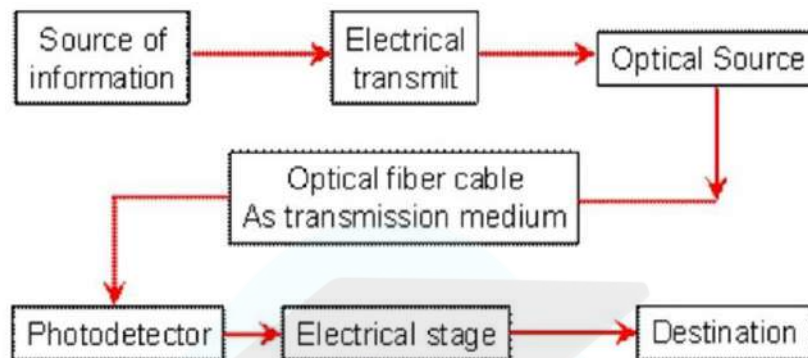

Fig.5.1 optical fiber optical communication system

Optical fiber is backbone of communication system it carry a signal with a speed up to 1Tbit/sec or 100 million conversation simultaneously.

### 5.1.1 Structure of optical fiber

**Core-** Central tube of very thin size made up of optically transparent dielectric medium and carries the light form transmitter to receiver.

**Cladding-** Outer optical material surrounding the core having refractive index lower than core. It helps to keep the light within the core throughout the phenomena of total internal reflection.

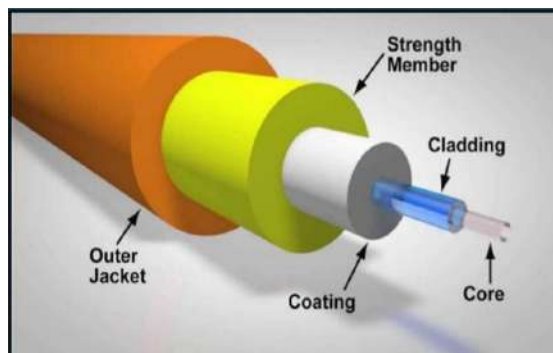

Fig. 5.1 Structure of optical fiber



**Jacket-** Plastic coating that protects the fiber from external interference is made of silicon rubber .

### 5.1.2 Propagation Mechanism and communication in optical fiber:

Optical fiber is a wave guide used for optical communication. It is made of transparent dielectric materials whose function is to guide the light wave. An optical fiber consists of an inner cylindrical portion of glass, called core. The function of core is to carry the light from one end to another end by the principle of total **internal reflection**. When an ray of light travels from a denser to a rarer medium such that the angle of incidence is greater than the critical angle, the ray reflects back into the same medium this phenomena is called TIR. The core is surrounded by another cylindrical covering called cladding. The refractive index of core is greater than the refractive index of cladding. Cladding helps to keep the light within the core. In the optical fiber the rays undergo repeated total number of reflections until it emerges out of the other end of the fiber, even if fiber is bending. The propagation of light inside the optical fiber is shown in Fig.5.2

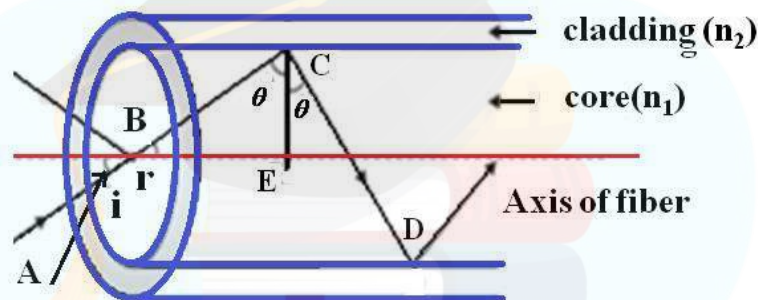

**Fig. 5.2 Propagation Mechanism in optical fiber**

Let  $i$  be the angle of incidence of the light ray with the axis and  $r$  the angle of refraction. If  $\theta$  be the angle at which the ray is incident on the fiber boundary, then  $\theta = (90 - r)$ .

Let  $n_1$  and  $n_2$  be the refractive index of the core and clad of fiber. If  $\theta \geq \theta_c$  critical angle

then the ray is totally internally reflected where  $\sin \theta_c = \frac{n_2}{n_1}$

## 5.2 Acceptance angle, acceptance cone and numerical aperture.

### 5.2.1 Acceptance angle

The acceptance angle is the maximum angle from the fiber axis at which light may enter the fiber so that it will propagate in the core by total internal reflection. If a ray is rotated around the fibre axis keeping  $i$  acceptance angle same, then it describes a conical surface called cone as shown in Fig.2. Now only those rays which are coming into the fiber within this cone having a full angle  $2i$  will only be totally internally reflected and this confined within the fiber for propagations. Therefore this cone is called as **acceptance cone**. Consider a cylindrical optical fiber wire which consists of inner core of refractive index  $n_1$  and an outer cladding of refractive index  $n_2$  where  $n_1 > n_2$ . The typical propagations of light in optical fiber are shown in figure 5.3.

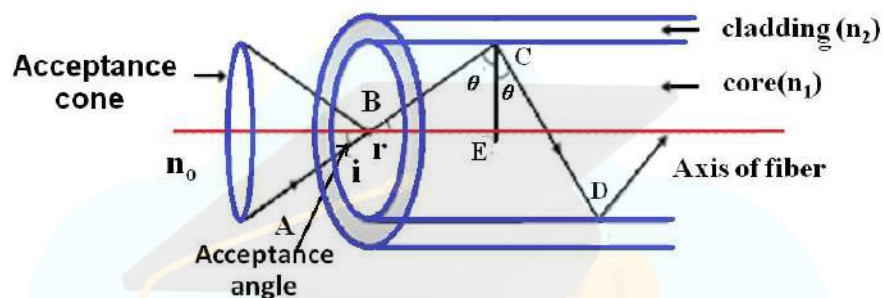

Fig. 5.3 Propagation Mechanism in optical fiber

Now we will calculate the angle of incidence  $i$  for which  $\theta > \theta_c$  (critical angle) so that the light rebounds within the fiber. Applying Snell's law of refraction at entry point of the ray AB.

$$n_0 \sin i = n_1 \sin r \quad \dots\dots\dots(1)$$

Where  $n_0$  is the refractive index of medium from which the light enters in the fiber. From triangle BCE,  $r = (90^\circ - \theta)$

$$\therefore \sin r = \sin(90^\circ - \theta)$$

$$\sin r = \cos \theta \quad \dots\dots\dots(2)$$

Substituting the value of  $\sin r$  from Equation (2) in Equation (1), We get,  $n_0$

$$\sin i = n_1 \cos \theta$$

$$\sin i = n_0 \sqrt{1 - \cos^2 \theta} \quad \dots\dots\dots(3)$$

Unit-V-Fiber Optics and Laser

CO5

If  $i$  is increased beyond a limit,  $\theta$  will drop below the critical value  $\theta_c$  and the ray will escape from the side walls of the fiber. The largest value of  $i$  which is  $i_{max}$  occurs when  $\theta = \theta_c$ . Applying this condition in

Equation (3),

$$n_1 \cos \theta_c = n_0 \sin i_{max} \tag{4}$$

$$\cos \theta_c = \sqrt{1 - \sin^2 \theta_c} = \frac{\sqrt{n_1^2 - n_2^2}}{n_1}$$

where

$$\sin \theta_c = \frac{c}{n_1}$$

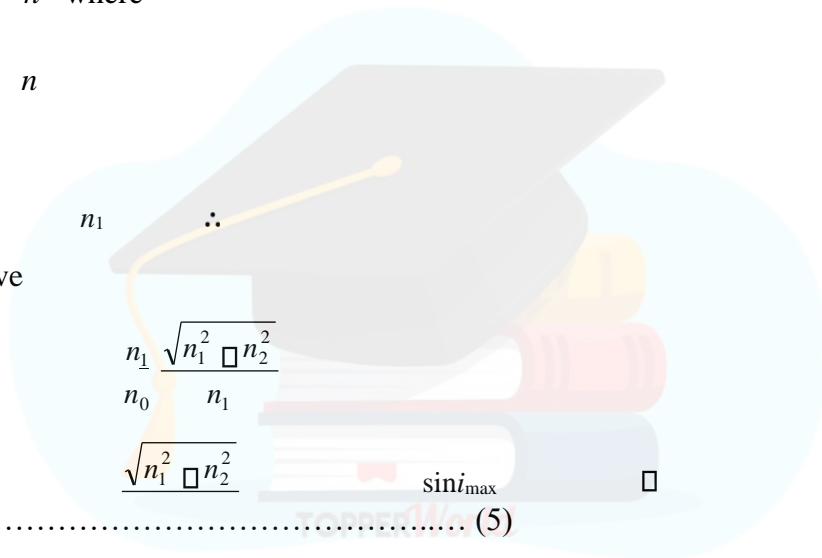

Equation (4), we have

$$\sin i_{max} = \frac{n_1 \sqrt{n_1^2 - n_2^2}}{n_0 n_1} = \frac{\sqrt{n_1^2 - n_2^2}}{n_0} \tag{5}$$

Almost all the time the ray is launched from air medium, then  $n_0 = 1$  and  $i_{max} = i$

$$\sin i = \sqrt{\left( \frac{n_1^2 - n_2^2}{n_0^2} \right)}$$

Where  $i$  is called acceptance angle of the fiber.

$\therefore i = \sin^{-1} \left( \sqrt{n_1^2 - n_2^2} \right)$ . Hence the acceptance angle is defined as the maximum angle from the fiber axis at

which light may enter the fiber so that it will propagate in the core by total internal reflection.

Now the light contained within the cone having a full angle  $2i$  are accepted and transmitted through fiber.

The cone associated with the angle  $2i$  is called acceptance cone as shown in Fig.5.2

**5.2.2 Numerical aperture:** Numerical aperture (NA) is a measure of the amount of light rays that can be accepted by the fiber and is more generally used term in optical fiber. Numerical aperture „NA“ determines the light gathering ability of the fiber. So it is a measure of the amount of light that can be accepted by the fiber. This is also defined as,

$$NA = \sin i$$

$$\therefore NA = n_1 \sqrt{n_2^2 - n_1^2} \dots\dots\dots (6)$$

The NA may also be derived in terms of relative refractive index difference  $\Delta$  as,

$$n_1 \sin i = n_2 \sin r$$

$$n_1^2 \sin^2 i = n_2^2 \sin^2 r$$

Hence  $\sin^2 r = \frac{n_1^2 \sin^2 i}{n_2^2}$  Now From Equation (6)

$$\therefore NA = n_1 \sqrt{1 - \frac{n_1^2 \sin^2 i}{n_2^2}}$$



substitute the value of  $\sin^2 r$  then after solving above equation will be Now

$$\therefore NA = n_1 \sqrt{1 - \frac{n_1^2 \sin^2 i}{n_2^2}}$$

Hence the numerical aperture is depends upon the relative refractive index

**5.2.3 Parameter/V-Number:**

The number of modes of multimode fiber cable depends on the wavelength of light, core diameter and material composition .This can be determined by the normalized frequency parameter (V) express as

$$V = \frac{2\pi a}{\lambda} \sqrt{n_1^2 - n_2^2} = \frac{2\pi a}{\lambda} (NA)$$

Where  $d$  is diameter of fiber core diameter and  $\lambda$  is wavelength of light and NA is numerical aperture. For a single mode fiber  $V$  less than 2.04 and for multimode it is greater than 2.04. Mathematically the numbers of modes are related to  $V$ -number (a) **For steps index optical fiber.**

$$N_{si} \approx \frac{V^2}{2}$$

(b) **Graded index optical fiber is**

$$N_{di} \approx \frac{V^2}{4}$$

### 5.3 Classification of optical fiber:

Optical fiber is classified into two categories: based on:- 1)

The number of modes-

- Single mode fiber(SMF) and
- Multi-mode fiber(MMF)

2) The refractive index-

- Step index optical fiber
- Graded- index optical fiber

#### 5.3.1 Types of optical fiber on basis of number of modes

##### i) Single mode fiber-

In single mode fiber only one mode can propagate through the fiber shown in fig.5.4. It has small core diameter (5 $\mu$ m) and cladding diameter is up to 70 $\mu$ m. The difference in refractive index between the core and clad are very small. Because of this, the number of light reflections created as the light passes through the core decreases, lowering attenuation and creating the ability for the signal to travel further. Due to negligible dispersion it is typically used in long distance, higher bandwidth applications.

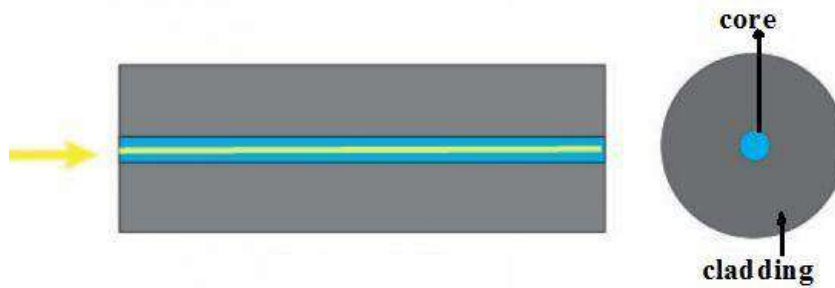

Fig. 5.4 Single mode optical fiber

**(ii) Multi-mode fiber**

It allows a large number of modes for light ray travelling through it. The **core** diameter is 40um and that of cladding is 70um. The relative refractive index difference is also large than single mode fiber shown in fig.5.5.

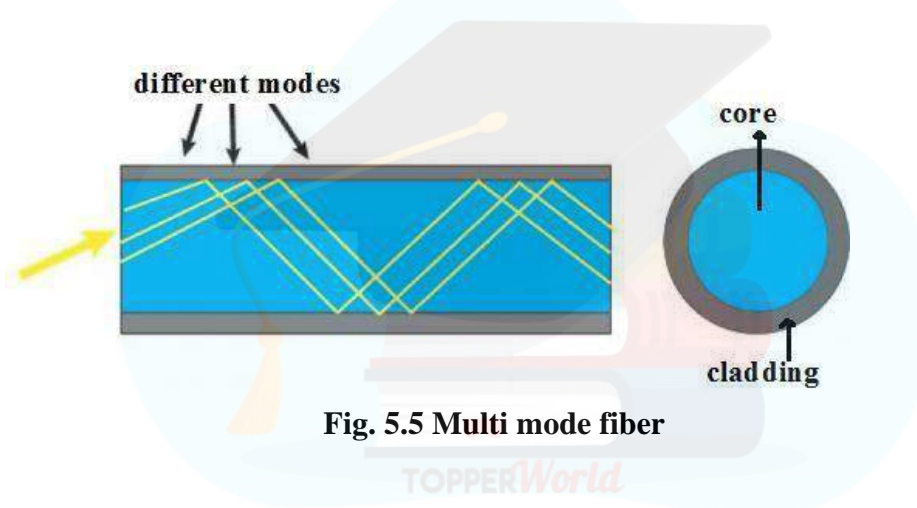

Fig. 5.5 Multi mode fiber

**5.3.2 Types of optical fiber on the basis of refractive index**

- There are two type of optical fiber:- 1) Step index optical fiber
- Single Mode
- Multi Mode

## 2) Graded- index optical fiber

**i) Step Index fiber:-** Step-index optical fiber-the refractive index of core and cladding are constant. These types of fibers have sharp boundaries between core and cladding with defined indices of refraction shown in fig.5.6 a. The entire core uses single index of refraction. The light ray propagates through it in the form of Zig Zag path .which cross the fiber axis during every reflection at the core cladding boundary.

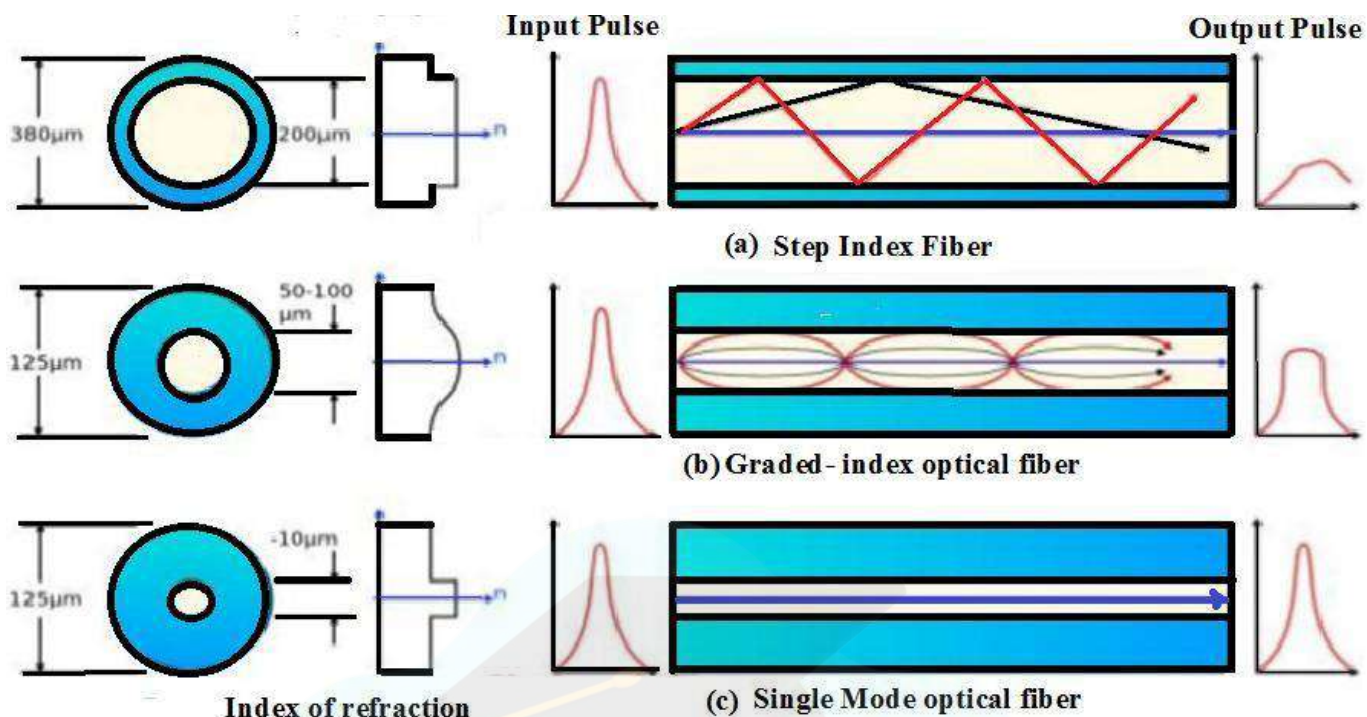

Fig. 5.6 (a) Multi mode step index fiber (b) graded index multimode optical fiber (c) single mode step index optical fiber.

**ii) Multimode graded Index Fiber:**

In this type of fiber core has a non uniform refractive index that gradually decrease from the center towards the core cladding interface. The cladding has a uniform refractive index. The light rays propagate through it in the form of helical rays. They never cross the fiber axis. In Graded-index fiber's refractive index decreases gradually away from its center, finally dropping to the same value as the cladding at the edge of the core the propagation mechanism are shown in Fig 5.6 b.

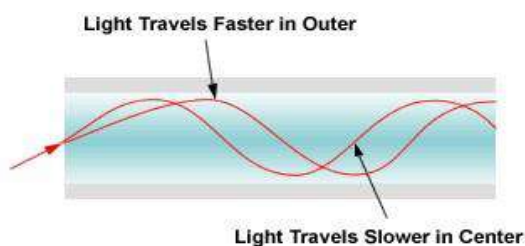

Fig. 5.6 Propagation in graded index multimode optical fiber



The rays in graded index light signals travels helical path instead of zigzag. The ray near to the core axis travels small distance with less velocity as compared to those who are far away from the core axis. The higher refractive index of core reduced the velocity of signal as compare to the other region away from the core. Therefore arrival timing at output end of different signals are almost equal. Hence the modal dispersion minimizes. **5.4 Losses in optical fiber**

The information carrying capacity of optical fiber are depends upon the losses in the optical fiber A beam of light carrying signals travels through the core of fiber optics and the strength of the light will become lower leads to signal strength becomes weaker. This loss of light power is generally called fiber optic loss. It is basically comes in the form of

- 1) Attenuation
- 2) Dispersion

**5.4.1 Attenuation**

The reduction in amplitude of signal as it is guided through the fiber known as attenuation. It is expressed in decibel (dB)

$$P_{out} \text{ dB} = 10 \log_{10} \frac{P_{in}}{P_{out}}$$

$$= \frac{10}{L} \log_{10} \frac{P_{in}}{P_{out}}$$

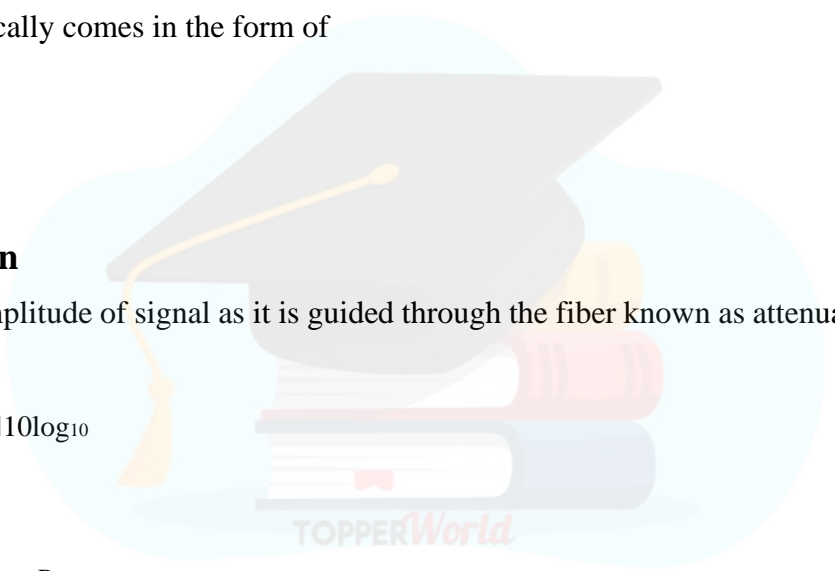

Where L=in Km

α=attenuation coefficients of fiber in dB/Km Since attenuation is loss,there for it is expressed as

$$P_{out} = P_{in} 10^{-\alpha L}$$

Attenuation in optical fiber communication is due to following way i)

**Absorption:**

Absorption is the most prominent factor causing the attenuation in optical fiber. The absorption of light may be because of interaction of light with one or more major components of glass or caused by impurities



within the glass. Following are the three main sources of absorption of light. **a) Impurities in fiber material:**

from transition metal ions & particularly from OH ions with absorption peaks at wavelengths 2700 nm, 400 nm, 950 nm & 725nm. **b) Intrinsic absorption:**

Electronic absorption band (UV region) & atomic bond vibration band (IR region) in basic SiO<sub>2</sub>.

Radiation defects **ii) Scattering Losses**

The variation in material density, chemical composition, and structural inhomogeneity scatter light in other directions and absorb energy from guided optical wave. The random variation of molecular position of glass create the random inhomogeneities of refractive index that act as a tiny center of scattering. The amplitude of scattering field is proportional to the square of frequency. The essential mechanism is the Rayleigh scattering.

**iii) Bending Loss (Macro bending & Micro bending)**

Bending losses occur due to imperfection and deformation present in the fiber structure. These are of two types

**a) Micro bending:** If microscopic bends of the fiber axis that can arise when the fibers are incorporated into cables. The power is dissipated through the micro bended fiber. There is repetitive coupling of energy between guided modes & the leaky or radiation modes in the fiber.

**b) Macrobending Loss:** These types of loss are due to excessive bending and crushing of fiber. The curvature of the bend is much larger than fiber diameter. Light wave suffers sever loss due to radiation of the evanescent field in the cladding region. As the radius of the curvature decreases, the loss increases exponentially until it reaches at a certain critical radius. For any radius a bit smaller than this point, the losses suddenly become extremely large. The higher order modes radiate away faster than lower order modes.

## 5.5 Dispersion

When an optical signal or pulse is sent into the fiber the pulse spreads /broadens as it propagates through the fiber called dispersion. It is also defined as the distortion of light wave or pulse as it travels from one end of the fiber to the other end of fiber. The data or information to be transmitted through fiber is first coded in the forms of pulse after these pulses are transmitted through the optical fiber. Finally, these pulses

are received at the receiver and decoded. The light pulses, entering at different angles at input of fiber take different times to reach at the output end. Consequently the pulses are broadening at the output end. The pulses at input end, output ends are shown in Fig 5.7. “The deformation in the pulse is called pulse dispersion.”

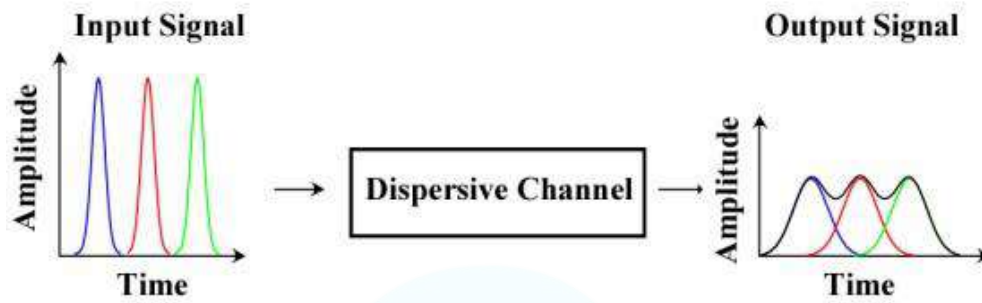

**Fig. 5.7 Dispersion in optical fiber**

In communication, dispersion is used to describe any process by which any electromagnetic signal propagating in a physical medium is degraded because the various wave characteristics (i.e., frequencies) of the signal have different propagation velocities within the physical medium. The pulse dispersion is of following types.

- (1) Intermodal dispersion or modal dispersion
- (2) Intermodal dispersion or chromatic dispersion

### **5.1.1 Intermodal dispersion or modal dispersion:**

Modal dispersion exists in multimode fibers. When a ray of light is launched into the fiber, the pulse is dispersed in all possible paths through the core, so called different modes. Each mode will be different wavelength and has different velocity as shown in the figure. Hence, they reach the end of the fiber at different time. This results in the elongation or stretching of data in the pulse. The higher order modes travel a long distance and arrive at the receiver end later than the lower order modes. In this way one mode travel more slowly than other mode shown in Fig 5.8 . Thus causes the distorted pulse. This is called intermodal dispersion. The mechanism of modal dispersion is, when light incident the fiber, it propagates in different mode.

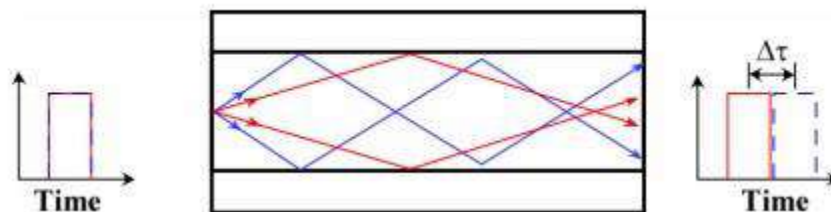

**Fig. 5.8 Intermodal dispersion or modal dispersion in optical fiber**

Hence in multi mode fiber many signals travel at same time. These signals enter the fiber with different angles to the fiber axis, these signals travels different distance with same velocity. A ray of light OA be incident at angle  $i$  on the entrance aperture of the fiber. The rays is refracted in to core along AB and makes an angle  $r$  with the axis of core and make an angle  $\theta$  with the axis of core. Now the ray is strike at the upper core cladding at B .After the ray is totally internally reflected back inside the core and strikes at C and D.Let  $t$  be the time taken by the light ray to cover the distance B to C and than C to D with velocity  $v$

$$t = \frac{BC + CD}{v}$$

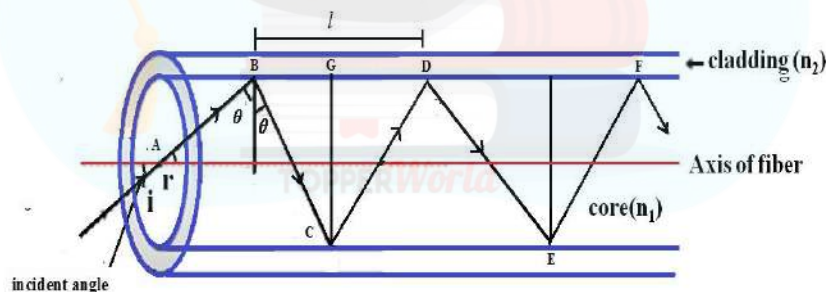

**Fig. 5.9 signal propagation in step index multimode optical fiber.**

If  $n_1$  be the core and  $c$  is the speed of light in vacuum

$$BC = \frac{BG}{\cos r}$$

$$CD = \frac{GD}{\cos r}$$

$$BC + CD = \frac{BG + GD}{\cos r} = \frac{l}{\cos r}$$

$$l \frac{n_1}{\cos r} = t_{\max} \frac{c}{n_2}$$

When the angle of incident in core clad interface is equal to the critical angle than the maximum time taken by the ray to reach is equal to the

$$r = \sin^{-1} \left( \frac{n_2}{n_1} \right)$$

$$t_{\max} = \frac{l}{c} \frac{n_1}{\cos r} \quad t_{\max} = \frac{l}{c} \frac{n_1}{\sin r}$$

The minimum time to reach the signal to come outside when the incident angle at the core air

$$r = 0$$

$$t_{\min} = \frac{n_1 l}{c}$$

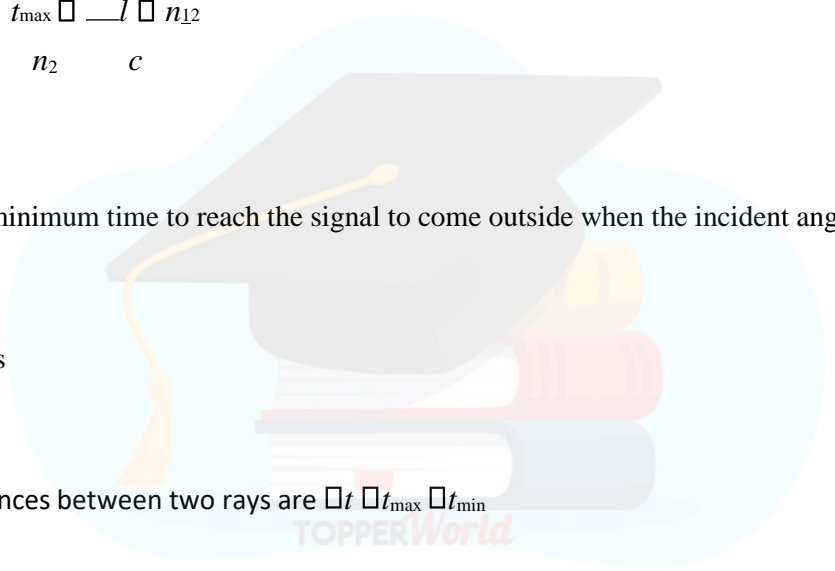

The total time differences between two rays are  $\Delta t = t_{\max} - t_{\min}$

$$\Delta t = \frac{l}{c} \left[ \frac{n_1^2}{\sin^2 r} - n_1 \right]$$

The relative refractive index between core and clad are related to numerical aperture are

$$NA = n_1 \sqrt{2} \sin \theta$$

$$\Delta t = \frac{l(NA)^2}{2n_1 c}$$

From Fig. The arrival timing are different for different signals. As a result output pulse broadens. The broadening of output pulse by travelling in multimode fiber is called modal dispersion. It is not suitable for long distance communication due to large dispersion

(2) **Material dispersion or spectral dispersion:** This is wavelength based effect. Also we know the refractive index of core depends upon wavelength or frequency of light when a input pulse with different components travels with different velocities inside the fiber, the pulse broadens. This is known as material dispersion shown in Fig.5.9

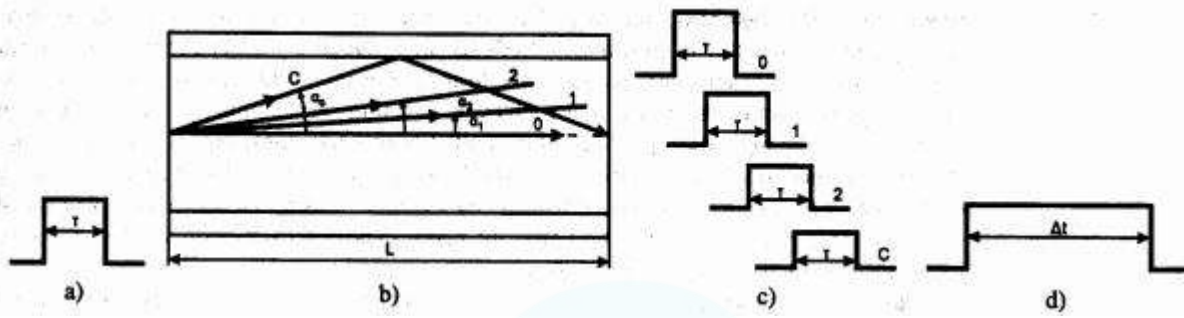

Fig. 5.9 Material dispersion in step index multimode optical fiber

(3) **Wave guide dispersion:** Due to wave guide structure the light rays in the fiber follow different paths. Therefore they take different time interval to travel these paths. This dispersion is called as waveguide dispersion.

### 5.6 Applications of optical fiber.

The important applications of optical fiber are,

- (1) Optical fibre communication has large bandwidth; it is capable of handling a number of channels. Hence it has wide applications in communication.
- (2) The optical fibre system is used in defence services because high security is maintained.
- (3) Optical fibre systems are particularly suitable for transmission of digital data generated by computers.
- (4) It is used for signaling purpose.
- (5) Optical fibres are used in medical endoscopy.

**5.7 LASER**

A laser is a device that emits light through a process of optical amplification based on the stimulated emission of electromagnetic radiation. Laser is "**light amplification by stimulated emission of radiation**".

**5.7.1 Laser Characteristics**

- The light emitted from a laser has a very high degree of coherence. whereas the light emitted from conventional light source is incoherent because the radiation emitted from different atoms do not bear any definite phase relationship with each other.
- The light emitted from a laser is highly monochromatic.
- Degree of non-monochromaticity is  $\frac{\Delta\lambda}{\lambda_0}$  —
- Lasers emit light that is highly directional, that is, laser light is emitted as a relatively narrow beam in a specific direction. Ordinary light, such as from a light bulb, is emitted in many directions away from the source.
- The intensity of Laser light is tremendously high as the energy is concentrated in a very narrow region and stays nearly constant with distance. The intensity of light from conventional source decreases rapidly with distance.

**5.7.2 Einstein's A,B Coefficients.**

In 1916, Einstein considered the various transition rates between molecular states (say, 1 & 2)

**a) Absorption:** When an atom encounters a photon of light, it can absorb the photon's energy and jump to an excited state. An atom in a lower level absorbs a photon of frequency  $h\nu$  and moves to an upper level.

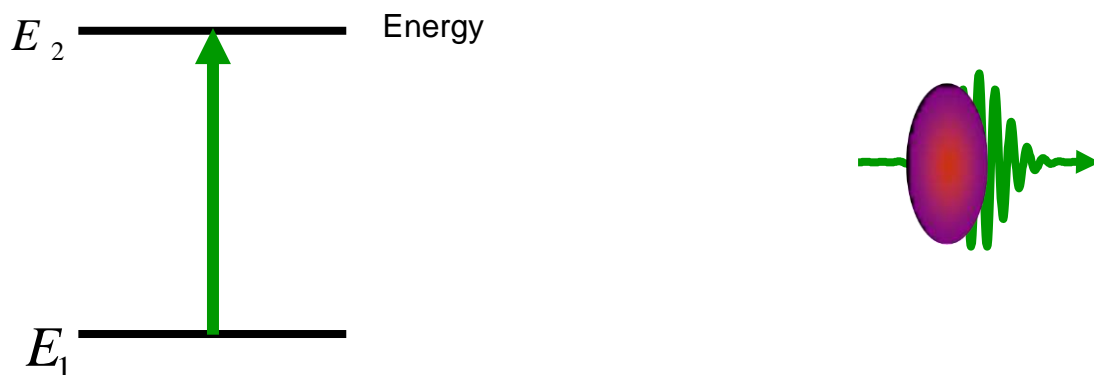

**Fig. 5.10 Stimulated Absorption**

Number of Absorption per unit time per unit volume is  $B_{12} N_1 u(\nu)$  where  $N_i$  is the number of atoms (per unit volume) in the  $i^{\text{th}}$  state,  $U(\nu) d\nu$  radiation energy per unit volume within frequency range  $\nu$  and  $\nu+d\nu$   $B_{12}$  the coefficient of proportionality and is a characteristic of the energy levels.

**b) Spontaneous emission:** Spontaneous emission is the process in which a quantum mechanical system (such as a molecule, an atom or a subatomic particle) transits from an excited energy state to a lower energy state (e.g., its ground state) and emits a quantized amount of energy in the form of a photon. An atom in an upper level can decay spontaneously to the lower level and emit a photon of frequency  $h\nu$ . if the transition between  $E_2$  and  $E_1$  is radiative. This photon has a random direction and phase. The rate of Spontaneous emission (per unit volume) =  $A_{21} N_2$  where  $A_{21}$  is the proportionality constant



**Fig. 5.11. Spontaneous emission Molecules**

typically remain excited for no longer than a few nanoseconds.

**c) Stimulated Emission**

When a photon encounters an atom in an excited state, the photon can induce the atom to emit its energy as another photon of light, resulting in two photons. An incident photon causes an upper level atom to decay, emitting a “stimulated” photon whose properties are identical to those of the incident photon. The term “stimulated” underlines the fact that this kind of radiation only occurs if an incident photon is present. The schematic diagram of process is shown in fig.5.12. The amplification arises due to the similarities between the incident and emitted photons.

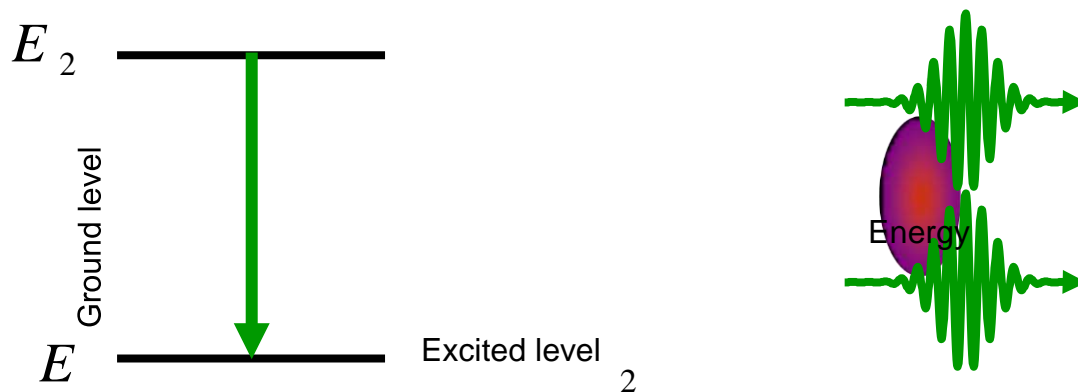

Fig. 5.12. Stimulated emission

The rate of stimulated emission are  $B_{21} N_2 u(\nu)$

**5.7.3 Relation between Einstein’s A, B Coefficient:** Einstein first proposed stimulated emission in 1916. In thermal equilibrium, the rate of upward transitions equals the rate of downward transitions:

$$B_{12} N_1 u(\nu) = A_{21} N_2 + B_{21} N_2 u(\nu)$$

$$u(\nu) \left[ \frac{N_2 A_{21}}{N_1 B_{12}} + \frac{A_{21} + B_{21} N_2}{B_{21} N_2} \right] = \dots\dots\dots(1)$$

In equilibrium, the ratio of the populations of two states is given by the Maxwell- Boltzman distribution .  $N_2 / N_1 = \exp(-\Delta E/kT)$ , where  $\Delta E = E_2 - E_1 = h\nu$ ,  $k$  is the Boltzmann Constant .As a result, higher energy states are always less populated than the ground state. Acc. to **Planck’s blackbody radiation formula**

$$\frac{8\pi h\nu^3}{c^3} \frac{1}{e^{\frac{h\nu}{kT}} - 1} u(\nu) = \dots\dots\dots(2)$$

Comparing equation 1 and (2)

$$B_{12} = B_{21} \dots\dots\dots(3)$$



$$8 \frac{h\nu^3}{c^3} B_{21}$$

$$A_{21} \dots \dots \dots (4)$$

The number of spontaneous emission to the number of stimulated emission can be written as.

$$\frac{A_{21}}{B_{21}u(\nu)}$$

$$B_{21}u(\nu)$$

Case 1 : If  $h\nu \gg KT$

$$\frac{h\nu}{KT}$$

The number of spontaneous emission to the number of stimulated emission  $\frac{h\nu}{KT}$

Case 2: If  $h\nu \ll KT$  .The number of spontaneous emission to the number of stimulated emission  $\frac{h\nu}{KT} \ll 1$

For normal source at  $T \sim 10^3 K$ ,  $\lambda \sim 6000 \text{ \AA}$ ,  $\frac{h\nu}{KT} \ll 1$

The number of spontaneous emission to the number of stimulated emission  $\sim 10^{10}$  .The spontaneous emission are dominant.

### 5.7.4 Components of Lasers

#### 1) Active Medium:

The active medium may be solid crystals such as ruby or Nd:YAG, liquid dyes, gases like CO<sub>2</sub> or Helium/Neon, or semiconductors such as GaAs. Active mediums contain atoms whose electrons may be excited to a metastable energy level by an energy source shown in Fig. 5.13

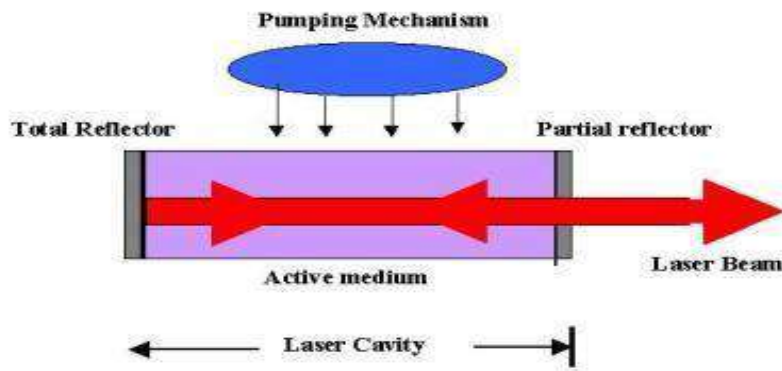

Fig. 5.13. Component of Laser

## 2 Excitation/Pumping Mechanism

Excitation of the lasing atoms or molecules by an external source of light (such as a lamp) or another laser. Excitation mechanisms pump energy into the active medium by one or more of three basic methods; optical, electrical or chemical.

## 3 Optical resonator/ cavity

### a) High Reflectance Mirror

A mirror which reflects essentially 100% of the laser light.

### b) Partially Transmissive Mirror

A mirror which reflects less than 100% of the laser light and transmits the remainder.

Gas lasers consist of a gas filled tube placed in the laser cavity. A voltage (the external pump source) is applied to the tube to excite the atoms in the gas to a **population inversion**. The number of atoms in any level at a given time is called the population of that level. Normally, when the material is not excited externally, the population of the lower level or ground state is greater than that of the upper level. When the population of the upper level exceeds that of the lower level, which is a reversal of the normal occupancy, the process is called **population inversion**. The light emitted from this type of laser is normally continuous wave (CW).

## **Lasing Action**

1. Energy is applied to a medium raising electrons to an unstable energy level.
2. These atoms spontaneously decay to a relatively long-lived, lower energy, metastable state.
3. A population inversion is achieved when the majority of atoms have reached this metastable state.

4. Lasing action occurs when an electron spontaneously returns to its ground state and produces a photon.

### 5.8 Population Inversion

In physics the redistribution of atomic energy levels that takes place in a system so that Laser action can occur. Normally, a system of atoms is in temperature equilibrium and there are always more atoms in low energy states ( $E_1$ ) than in higher ones ( $E_2$ ). Although absorption and emission of energy is a continuous process, the statistical distribution (population) of atoms in the various energy states is constant. When this distribution is disturbed by pumping energy into the system, a population inversion will take place in which more atoms will exist in the higher energy states than in the lower. Normally, when the material is not excited externally, the population of the lower level or ground state ( $N_1$ ) is greater than that of the upper level ( $N_2$ ). When the population of the upper level exceeds that of the lower level, which is a reversal of the normal occupancy, the process is called Population inversion shown in Fig 5.13.



Fig. 5.13. Population Inversion

To understand the concept of a population inversion, it is necessary to understand some thermodynamics and the way that light interacts with matter. To do so, it is useful to consider a very simple assembly of atoms forming a laser medium. Assume there are a group of  $N$  atoms, each of which is capable of being in one of two energy state: either

1. The ground state, with energy  $E_1$ ; or
2. The excited state, with energy  $E_2$ , with  $E_2 > E_1$ .
3. The number of these atoms which are in the ground state is given by  $N_1$ , and the number in the excited  $N_2$ . Since there are  $N$  atoms in total i.e.  $N = N_1 + N_2$
4. The energy difference between the two states, given by  $\Delta E_{12} = E_2 - E_1$

5. which determines the characteristic frequency  $\nu_{12}$  of light which will interact with the atoms; This is given by the relation  $E_2 - E_1 = h\nu_{12}$  where  $h$  being Planck's constant. If the group of atoms is in thermal equilibrium, the ratio of the number of atoms in each state is given by Maxwell Boltzman

$$\frac{N_2}{N_1} = \exp\left(\frac{E_2 - E_1}{KT}\right)$$

where  $T$  is the thermodynamic temperature of the group of atoms, and  $k$  is Boltzmann's constant.

### 5.9 Three-level Laser

In a three-level system, the **laser transition** ends on the ground state. The unpumped gain medium exhibits strong absorption on the laser transition. A **population inversion** and consequently net laser **gain** result only when more than half of the ions (or atoms) are **pumped** into the upper laser level. the threshold pump power is thus fairly high. The schematic diagram of three levels laser are shown as Fig. 5.14.

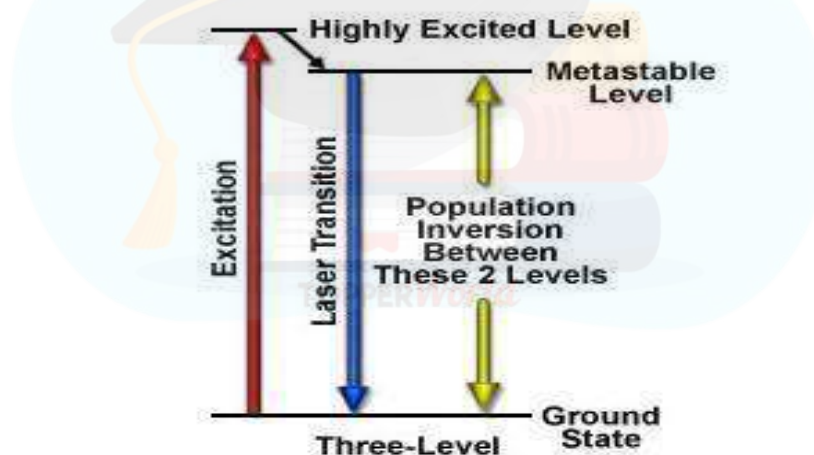

Fig. 5.14. Diagram of Three Level Laser

- The population inversion can be achieved only by pumping into a higher-lying level, followed by a rapid radiative or non-radiative transfer into the upper laser level,
- Avoids stimulated emission caused by the pump wave. (For transitions between only two levels, simultaneous pump absorption and signal amplification cannot occur.) hence we can say in three level laser
- Initially excited to a short-lived high-energy state.

- Then quickly decay to the intermediate metastable level.

Population inversion is created between lower ground state and a higher-energy metastable state. An example of a three-level laser medium is **ruby** ( $\text{Cr}^{3+}:\text{Al}_2\text{O}_3$ ), as used by Maiman for the first laser

### 5.10 Four-level laser

A lower threshold pump power can be achieved with a four-level laser medium, where the lower laser level is well above the ground state and is quickly depopulated e.g. by multi-phonon transitions. Ideally, no appreciable population density in the lower laser level can occur even during laser operation. Reabsorption of the laser radiation is avoided (provided that there is no absorption on other transitions). This means that there is no absorption of the gain medium in the unpumped state, and the gain usually rises linearly with the absorbed pump power.

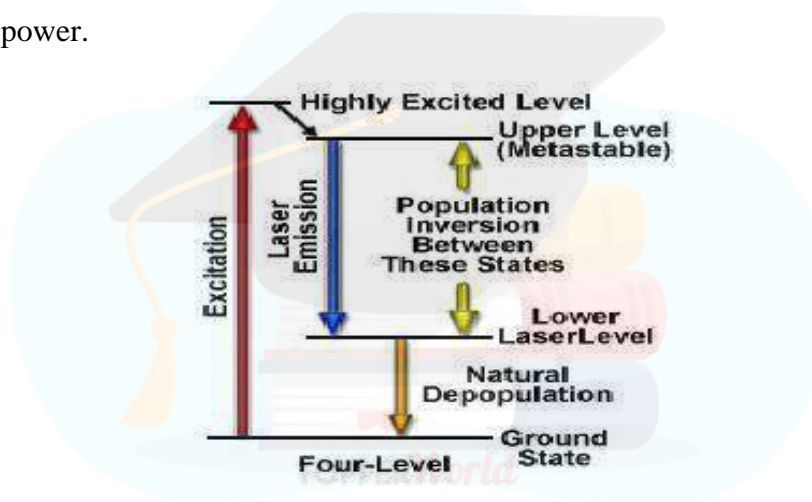

Fig. 5.15. Diagram of Four Level Laser

The most popular four-level solid-state gain medium is Nd:YAG. All lasers based on neodymium-doped gain media, except those operated on the ground-state transition around 0.9–0.95  $\mu\text{m}$ , are four-level lasers. Neodymium ions can also be directly pumped into the upper laser level, e.g. with pump light around 880 nm for Nd:YAG. Even though effectively only three levels are involved, the term three-level system would not be used here

### 5.11 Types of Laser

The Laser are classified

- According to the state of laser medium: solid, liquid or gas.

- According to the wavelength: Infra-red, visible, ultra-violet (UV) or x-ray lasers.
- According to the nature of output: Pulsed or Continuous (direct) wave lasers.
- According to the energy level system: Two level lasers(e.g., semi-conductor lasers), three level lasers(e.g., Ruby laser), four level lasers(Nd: YAG, He-Ne, CO2 lasers).
- According to the manner of pumping: e.g., electric discharge , optical pumping, chemical reaction, direct conversion

### 5.11.1 Ruby laser

- First laser to be operated successfully
- Lasing medium: Matrix of Aluminum oxide doped with chromium ions
- Energy levels of the chromium ions take part in lasing action
- A three level laser system

The construction of ruby Laser is shown in Fig. 5.16.

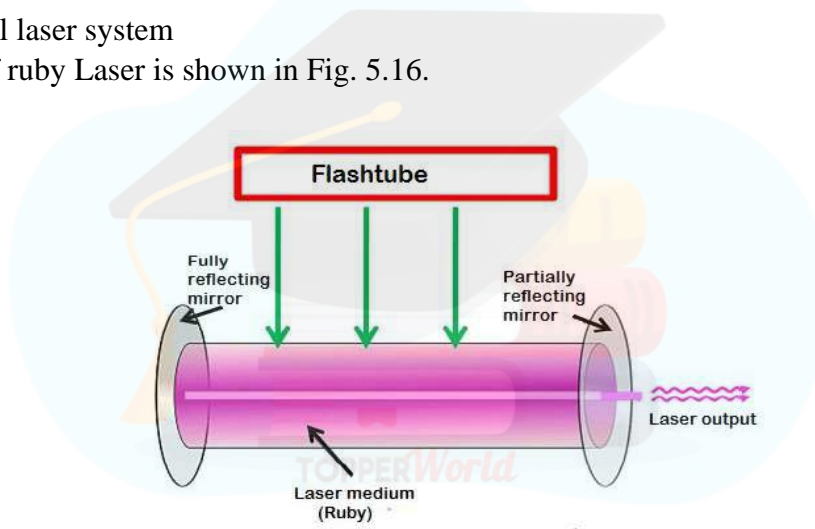

**Fig. 5.16. Construction of Ruby Laser**

**Working:** Ruby is pumped optically by an intense flash lamp. This causes Chromium ions to be excited by absorption of radiation around  $0.55\ \mu\text{m}$  and  $0.40\ \mu\text{m}$ .

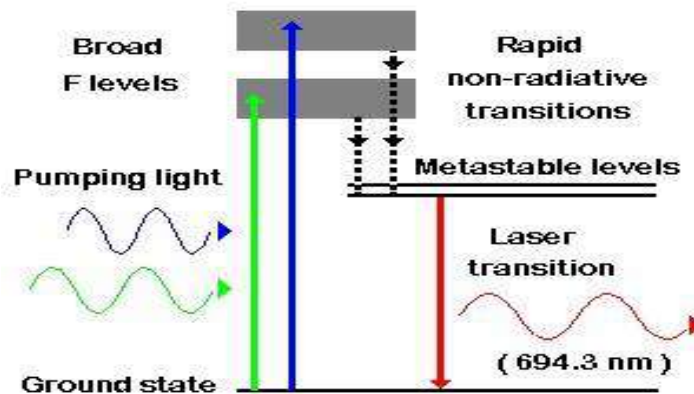

**Fig. 5.17. Energy level Diagram of chromium ions in Ruby Laser**

Chromium ions are excited from ground levels to energy levels  $E_1$  and  $E_2$  shown in Fig.5.17. Then the excited ions decay non-radiatively to the level M – upper lasing level M- metastable level with a lifetime of  $\sim 3$ ms. The Laser emission occurs between level M and ground state G at an output wavelength of 694.3 nm. Ruby laser is one of the important practical lasers which has long lifetime and narrow linewidth (Linewidth – width of the optical spectrum or width of the power Spectral density) The output lies in the visible region, where photographic emulsions and photodetectors are much more sensitive than they are in infrared region. It has applications in holography and laser ranging. Due to flash lamp operation leads to a pulsed output of the laser. In between flashes, the lasing action stops then the output is highly irregular function of time leads to Laser spiking. The Intensity of Ruby Laser has random amplitude fluctuations of varying duration.

### 5.11.2 He-Ne laser

A helium–neon laser or HeNe laser, is a type of gas laser whose gain medium consists of a mixture of helium and neon(10:1) inside of a small bore capillary tube, usually excited by a DC electrical discharge. It is four level laser give the continuous laser output. The construction of He-Ne Laser is shown in Fig.5.18. The best-known and most widely used He-Ne laser operates at a wavelength of 632.8 nm in the red part of the visible spectrum. The first He-Ne lasers emitted light at  $1.15 \mu\text{m}$ , in the infrared spectrum, and were the first gas lasers.

#### Schematic diagram of a Helium–Neon laser



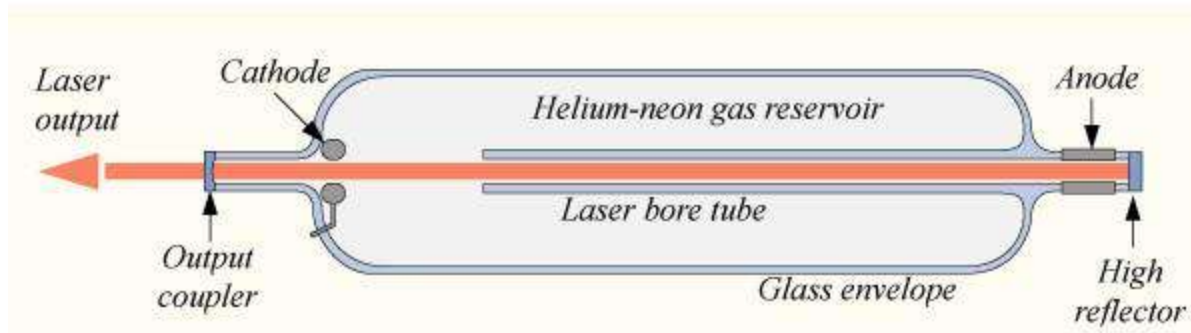

**Fig. 5.18. Construction of He-Ne Laser**

The gain medium of the laser, is a mixture of helium and neon gases, in approximately a 10:1 ratio, contained at low pressure in a glass envelope. The gas mixture is mostly helium, so that helium atoms can be excited. The excited helium atoms collide with neon atoms, exciting some of them to the state that radiates 632.8 nm. Without helium, the neon atoms would be excited mostly to lower excited states responsible for non-laser lines. A neon laser with no helium can be constructed but it is much more difficult without this means of energy coupling. Therefore, a HeNe laser that has lost enough of its helium (e.g., due to diffusion through the seals or glass) will lose its laser functionality since the pumping efficiency will be too low. The energy or pump source of the laser is provided by a high voltage electrical discharge passed through the gas between electrodes (anode and cathode) within the tube. A DC current of 3 to 20 mA is typically required for CW operation. The optical cavity of the laser usually consists of two concave mirrors or one plane and one concave mirror, one having very high (typically 99.9%) reflectance and the output coupler mirror allowing approximately 1% transmission.

Commercial HeNe lasers are relatively small devices, among gas lasers, having cavity lengths usually ranging from 15 cm to 50 cm (but sometimes up to about 1 metre to achieve the highest powers), and optical output power levels ranging from 0.5 to 50 mW.



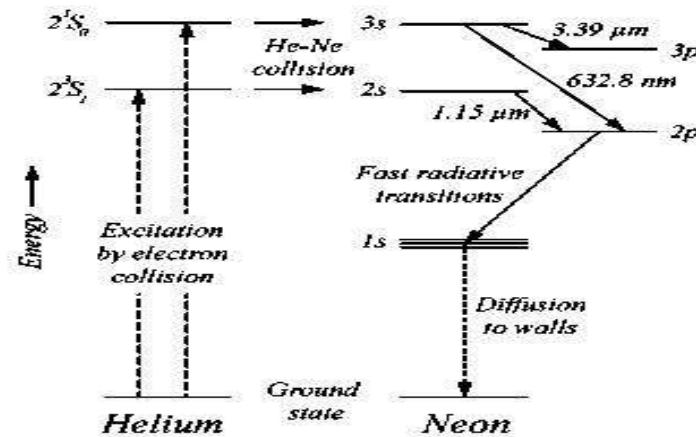

Fig. 5.19. Energy level Diagram of He-Ne Laser

The mechanism producing population inversion and light amplification in a He-Ne laser plasma originates with inelastic collision of energetic electrons with ground state helium atoms in the gas mixture. As shown in the accompanying energy level diagram in Fig.5.19, these collisions excite helium atoms from the ground state to higher energy excited states, among them the  $2^3S_1$  and  $2^1S_0$  long-lived metastable states. Because of a fortuitous near coincidence between the energy levels of the two He metastable states, and the  $3s^2$  and  $2s^2$  (Paschen notation) levels of neon, collisions between these helium metastable atoms and ground state neon atoms results in a selective and efficient transfer of excitation energy from the helium to neon.

### Applications of laser

#### 1. Scientific

a. Spectroscopy

b. Lunar laser ranging

c. Photochemistry

d. Laser cooling

e. Nuclear fusion

#### 2. Military

a. Death ray

b. Defensive applications

c. Strategic defense initiative

d. Laser sight

e. Illuminator

f. Target designator

