



BASIC ELECTRICAL ENGINEERING

B.Tech (1st yr.)

Notes

Prepared By:



Module 1: DC Circuits

Contents: Electrical circuit elements (R, L and C), Concept of active and passive elements, voltage and current sources, concept of linearity and linear network, unilateral and bilateral elements, Kirchhoff's laws, Loop and nodal methods of analysis, Star-delta transformation, Superposition theorem, Thevenin's theorem, Norton's theorem.

1. Electrical circuit elements (R, L and C): The interconnection of various electric elements in a prescribed manner comprises as an electric circuit in order to perform a desired function. The electric elements include controlled and uncontrolled source of energy, resistors, capacitors, inductors, etc. Analysis of electric circuits refers to computations required to determine the unknown quantities such as voltage, current and power associated with one or more elements in the circuit. To contribute to the solution of engineering problems one must acquire the basic knowledge of electric circuit analysis and laws. We shall discuss briefly some of the basic circuit elements and the laws that will help us to develop the background of subject.

a) Resistor: Resistor is a dissipative element, which converts electrical energy into heat when the current flows through it in any direction. The law governing the current into and voltage across a resistor is:

$$V = IR \quad \text{(i)}$$

The relationship is known as Ohm's law.

But resistor can be regarded as linear only within the specified limits, outside which the behavior becomes non-linear. The resistance of a resistor is temperature dependent and rises with temperature.

Mathematically it can be represented as:

$$R = R_0 (1 + \alpha \theta) \quad \text{(ii)}$$

Where R_0 = Resistance at 0°C and R = Resistance at $^\circ\text{C}$

α = Temperature coefficient and it may be positive and negative both

θ = Temperature in $^\circ\text{C}$

And power dissipated by resistor is $P = I^2 R$.

$$P = \frac{v^2}{R} \text{ Watts}$$

Resistor is represented by the symbol Unit of Resistance is ohm (Ω)



b) Capacitor (C): It is a two terminal element that has the capability of energy storage in electric field. The law governing the Q – relationship of capacitor is:

$$Q = CV \quad \text{(iii)}$$

After integrating equation (iii), we get

$$Q = -\int i dt + Q(0) \quad \text{(iv)}$$

Where $Q(0)$ = Capacitor voltage at $t = 0$, for initially uncharged capacitor

$$Q(0) = 0$$

Hence,
$$v = -\int i dt \tag{v}$$

The above expressions show that the voltage of a capacitor cannot change instantaneously.

Energy stored in capacitor can be represented by

$$W = \int v i dt = \int v dq = \int v \cdot C dv = \frac{1}{2} C v^2 \tag{ix}$$

Capacitor is represented by the symbol
Unit of Capacitance is Farad (F)



c) Inductor (L): It is a two-terminal storage element in which energy is stored in the magnetic field. The – relation of an inductance is:

$$v = L \frac{di}{dt} \tag{vi}$$

After integrating expression (vi), we get

$$v dt = L di + (0) \tag{vii}$$

Where (0) = Inductor current at $t = 0$, for initially if current through inductor $i(0) = 0$

Hence,
$$i = \frac{1}{L} \int v dt \tag{viii}$$

The above expressions show that the current through an inductor cannot change instantaneously.

Energy stored in inductor can be represented by

$$W = \int v i dt = \int i L di = \frac{1}{2} L i^2 \tag{ix}$$

Inductor is represented by the symbol
Unit of Inductance is Henry (H)

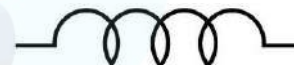

2. Concept of active and passive elements:

Electrical Network: Any possible combination of various electric elements (Resistor, Inductor, Capacitor, Voltage source, Current source) connected in any manner what so ever is called an electrical network. We may classify circuit elements in two categories, passive and active elements.

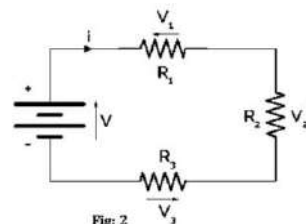
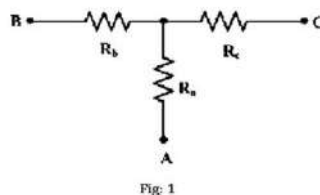

Electrical Circuit: An electric circuit is a closed energized electric network. It means circuit must have closed path with energy sources. From the above example, we can say that fig 1 and fig 2 are electric networks but only fig 2 is electric circuit.

It means, electric circuit is always an electric network but electric network may or may not be an electric circuit.

Passive Element: The element which receives energy (or absorbs energy) and then either converts it into heat (R) or stored it in an electric (C) or magnetic (L) field is called passive element, and the network containing these elements without energy sources are known as passive network. Examples are resistor, inductor, capacitor, transformer etc.

Active Element: The elements that supply energy to the circuit is called active element and the network containing these sources together with other circuit elements are known as active network. Examples of active elements include voltage and current sources, generators, and electronic devices that require power supplies. A transistor is an active circuit element, meaning that it can amplify power of a signal.

3. Energy Sources (Voltage and Current Sources): There are two types of energy sources namely Voltage Sources and Current Sources.

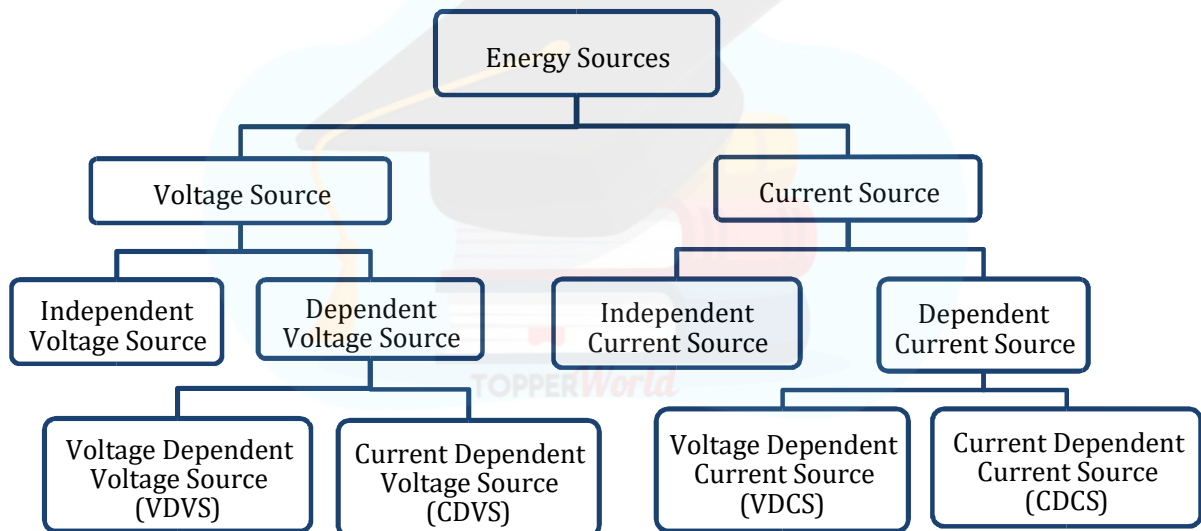

Here, we shall study only about independent voltage source and independent current source.

a) Independent Voltage Source: A hypothetical generator which maintains its value of voltage independent of the output current. It can be represented as:

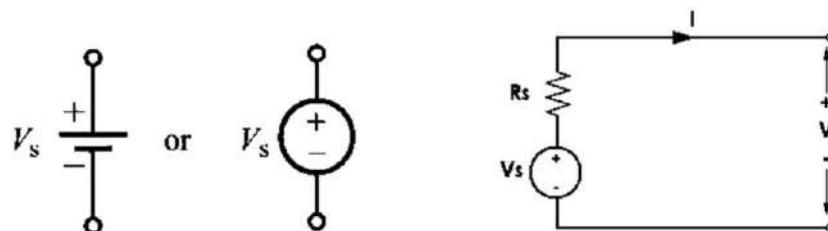

Fig: Ideal DC Voltage Source

Fig: Practical DC Voltage Source

If the value of internal resistance will be zero, then the voltage source is called as ideal voltage source. The V-I characteristics for ideal and practical voltage source is given below:

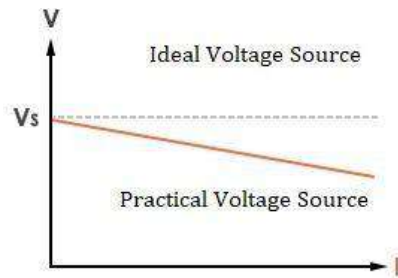

Fig: V-I Characteristic of Voltage Source

b) Independent Current Source: A generator which maintains its output current independent of the voltage across its terminals. It can be represented as:

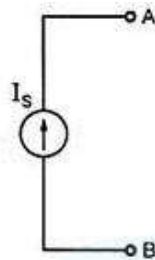

Fig: Ideal DC Current Source

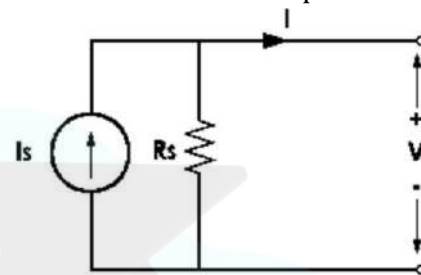

Fig: Practical DC Current Source if the

value of internal resistance will be infinity, then the current source is called as ideal current source. The V-I characteristics for ideal and practical current source is given below:

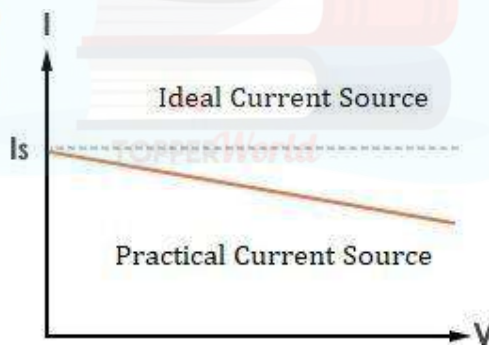

Fig: V-I Characteristic of Current Source

4. Concept of Linearity and Linear Network: For a network to be linear, it should have to follow the principle of superposition and homogeneity both.

Principle of Superposition: An element or circuit obeys the principle of superposition if the net effect of the sum of causes equals the sum of their individual effects.

Mathematically, let cause x and effect y be related as:

$$y = kx \quad (i)$$

Let the cause be scaled by a factor α . Then the functional relationship obeys homogeneity, if

$$y(\alpha x) = \alpha y(x) \quad (ii)$$

Consider two causes , then () = () =

Let the combined effect of these two causes be scaled by and respectively. The principle of superposition then yields if:

$$(+) = () + () \quad \text{(iii)}$$

If homogeneity is also satisfied, then

$$(+) = () + () = + \quad \text{(iv)}$$

A functional relationship is said to be linear if it obeys both superposition and homogeneity. Any element governed by such a functional relationship is linear. A circuit composed of such elements would also be linear.

5. Unilateral and Bilateral Elements:

Bilateral Elements: If by reversing the terminal connections of an element in a circuit, the circuit response remains same. Such elements are known as bilateral

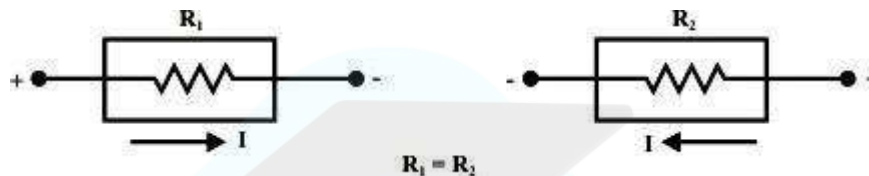

elements. Examples are Resistor, Inductor, Capacitor etc.

Unilateral Elements: If by reversing the terminal connections of an element in a

circuit, the circuit response gets change. Such elements are called as unilateral elements. Examples are Voltage Source, Current Source, Diode etc.

6. Kirchhoff's laws: There are two types of Kirchhoff's Law.

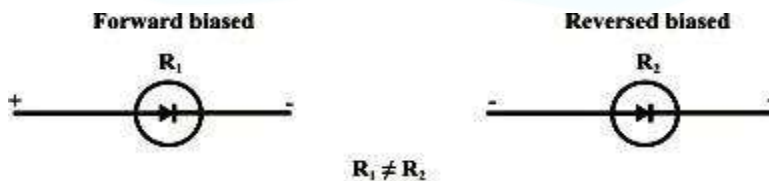

1. Kirchhoff's First Law or Kirchhoff's Current Law (KCL)
2. Kirchhoff's Second Law or Kirchhoff's Voltage Law (KVL)

1. Kirchhoff's First Law or Kirchhoff's Current Law (KCL): Kirchhoff's current law states that, in a given electric circuit, algebraic sum of all the currents meeting at a junction is always zero. In another way we can say that, the total current flowing towards a junction is equal to the total current flowing away from that junction. This law works on the principle of conservation of charge.

Sign Convention: If we take direction of current towards the junction as positive (+) sign then direction of current away from the junction will be taken as negative (-) sign or vice-versa.

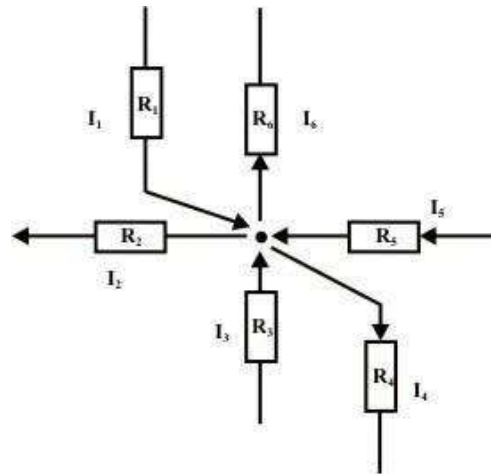

According to Kirchhoff's Current Law in the above circuit diagram:

$$- + - + - = 0$$

$$= 0$$

2. Kirchhoff's Second Law or Kirchhoff's Voltage Law (KVL): Kirchhoff's voltage law states that, "In any electric circuit, the algebraic sum of the voltage drops across the circuit elements of any closed path (or loop or mesh) is equal to the algebraic sum of the EMFs in the path".

In other words, "The algebraic sum of all the branch voltages around any closed path or closed loop is always zero". This law works on the principle of conservation of energy. Limitation of this law is that it can only be applied to **planner network**.

Sign Convention: If we take voltage rise with positive (+) sign then voltage drop will be taken with negative (-) sign or vice-versa. When current direction will be from negative terminal to positive terminal, voltage will rise and vice-versa. In all the passive elements current entering terminal is taken as positive and current leaving terminal is taken as negative.

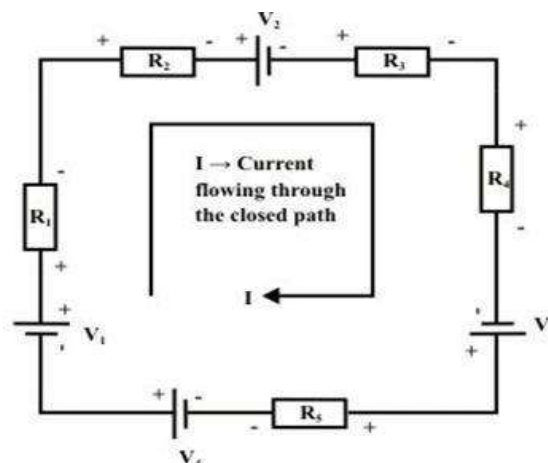

According to KVL in the above circuit diagram:

$$1 - 1 - 2 - 2 - 3 - 4 + 3 - 5 + 4 = 0$$

7. **Loop and Nodal Methods of Analysis:** For study of Loop and Nodal Methods of Analysis, knowledge of basic fundamentals are essential.

Some Basic Definitions:

1. **Node:** A node of a network is an equipotential surface at which two or more circuit elements are joined.
2. **Junction:** A junction is that point in an electric circuit where three or more elements are joined.

So, we can say that junction is always a node but node may or may not be a junction.

3. **Loop:** A loop is any closed path of the electric network.
4. **Mesh:** A mesh is the most elementary form of loop, and it cannot be further subdivided into other loops.

So, we can say that mesh is always a loop but loop may or may not be a mesh.

5. **Lumped Network:** A network in which physically separate resistors, capacitors and inductors can be represented.
6. **Distributed Network:** One in which resistors, capacitors, and inductors cannot be physically separated and individually isolated as separate elements. For example, Transmission Line.

Loop or Mesh Analysis Method: Mesh analysis is also known as loop analysis method. Mesh analysis is used to find the currents and voltages in a particular circuit.

Suppose in a particular electrical circuit, total number of branches are b , total number of nodes are n and total number of junctions are j , then total number of meshes ' m ' can be calculated by using the following expression:

$$m = b - (n - 1) \quad (i)$$

$$\text{Also, } m = b - (j - 1) \quad (ii)$$

Note: One thing make sure, when we consider nodes in the given electric circuit then branches will be counted according to the number of nodes, and equation (i) is used to calculate the total number of meshes. When we consider junction in that electrical circuit then branches will be counted according to junctions, and equation (ii) is used to calculate the total number of meshes. Using both the methods same number of meshes will be found for a particular circuit.

The independent mesh equations can be obtained by applying KVL to each independent mesh.

Mesh current is that current which flows around the perimeter of a mesh. Mesh currents may or may not have a direct identification with branch currents.

Mesh currents on the other hand, are fictitious quantity which are introduced because they allow us to solve problems in terms of a minimum number of unknowns.

Procedure of Mesh Analysis Method:

Step 1: Draw the circuit in which mesh currents or branch currents have to find. Calculate number of independent mesh equations by using the formula given below:

$$= - (- 1) \quad (i)$$

$$\text{Also, } = - (- 1) \quad (ii)$$

Step 2: Assume independent mesh currents for each mesh. You can choose any direction of the mesh current, but once you have chosen the direction of current, it should remain same throughout the question.

Step 3: Apply KVL for each mesh and write the expressions in terms of unknown mesh currents.

Step 4: Now, solve the equations by any method, either by simultaneous equation method or Cramer's Rule and find the unknown values.

Example 1: Find the current through 'ab-branch' () and voltage () across the current source using Mesh-current method in the given circuit diagram.

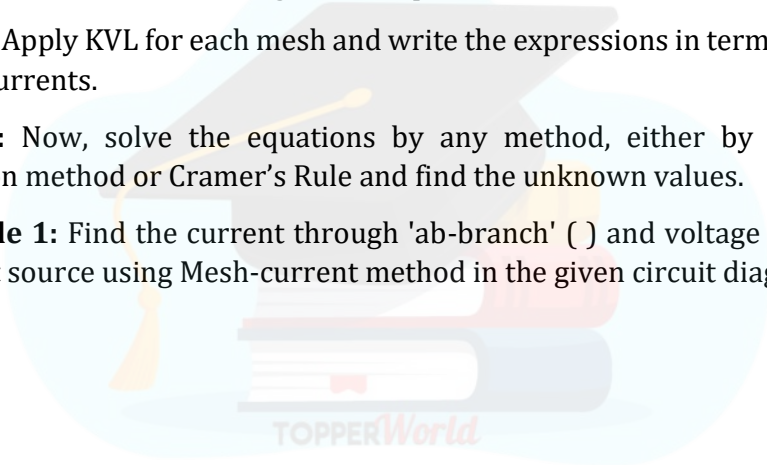

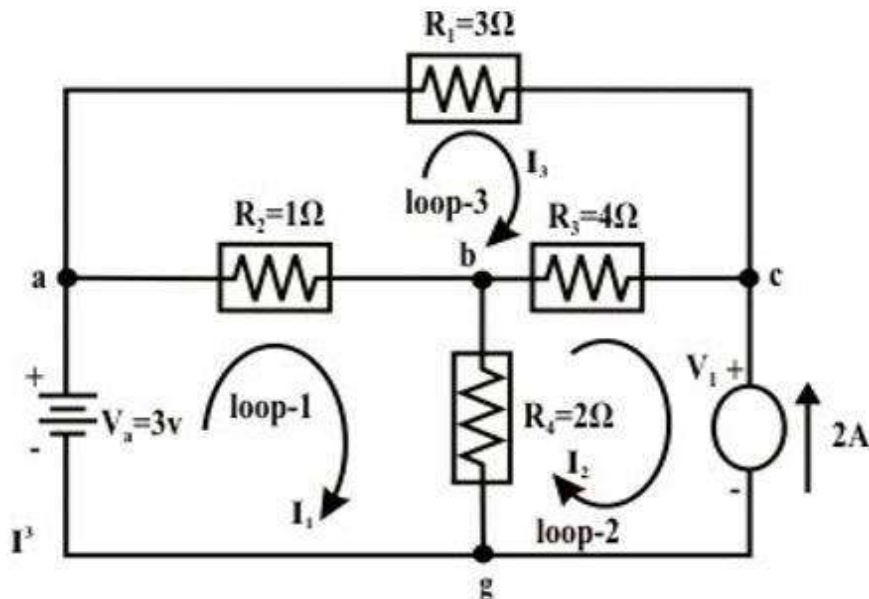

Solution: Assume voltage across the current source is v_1 ('c' is higher potential than 'g' (ground potential and assumed as zero potential) and note $I_2 = -2A$ (since assigned current direction (I_2) is opposite to the source current)

Loop - 1: (Applying KVL)

$$V_a - (I_1 - I_3)R_2 - (I_1 - I_2)R_4 = 0 \Rightarrow 3 = 3I_1 - 2I_2 - I_3$$

$$3I_1 - I_3 = -1 \quad (1)$$

Loop - 2: (Applying KVL)

Let us assume the voltage across the current source is v_1 and its top end is assigned with a positive sign.

$$-v_1 - (I_2 - I_1)R_4 - (I_2 - I_3)R_3 = 0 \Rightarrow -v_1 = -2I_1 + 6I_2 - 4I_3$$

$$2I_1 + 12 + 4I_3 = v_1 \quad (\text{note: } I_2 = -2A) \quad (2)$$

Loop - 3: (Applying KVL)

$$-I_3 R_1 - (I_3 - I_2)R_3 - (I_3 - I_1)R_2 = 0 \Rightarrow -I_1 - 4I_2 + 8I_3 = 0$$

$$I_1 - 8I_3 = 8 \quad (\text{Note, } I_2 = -2A) \quad (3)$$

Solving equations (4.4) and (4.6), we get $I_1 = -\frac{48}{69} = -0.6956A$ and

$$I_3 = -\frac{25}{23} = -1.0869A, \quad I_{ab} = I_1 - I_3 = 0.39A, \quad I_{bc} = I_2 - I_3 = -0.913A \quad \text{and}$$

$$I_{bg} = I_1 - I_2 = 1.304A$$

-ve sign of current means that the current flows in reverse direction (in our case, the current flows through 4Ω resistor from 'c' to 'b' point). From equation (2), one can get $v_1 = 6.27 \text{ volt}$.

Another way: $-v_1 + v_{bg} + v_{bc} = 0 \Rightarrow v_1 = v_{cg} = 6.27 \text{ volt}$.

Nodal Methods of Analysis: Circuit analysis by this methods are solved by using the KCL at the junction of a particular given circuit.

Suppose, total number of junctions are j in a particular electrical circuit, then total number of node equations N can be calculated by using the following formula:

$$\text{Total number of Node Equations} = (j - 1) \quad \text{(i) Procedure}$$

of Nodal Methods of Analysis:

Step 1: Draw the electrical circuit in which node voltage or branch currents has to find using this method and calculate the total number of Node equations using the formula: $= (j - 1)$ (i)

Step 2: Assume independent node voltages for each junction except reference, because at reference junction voltage will always be zero.

Step 3: Apply KCL for each junction except reference.

Step 4: Finally solve the equations using different methods.

Example 2: Find the value of the current I flowing through the battery using 'Node voltage' method in the given circuit.

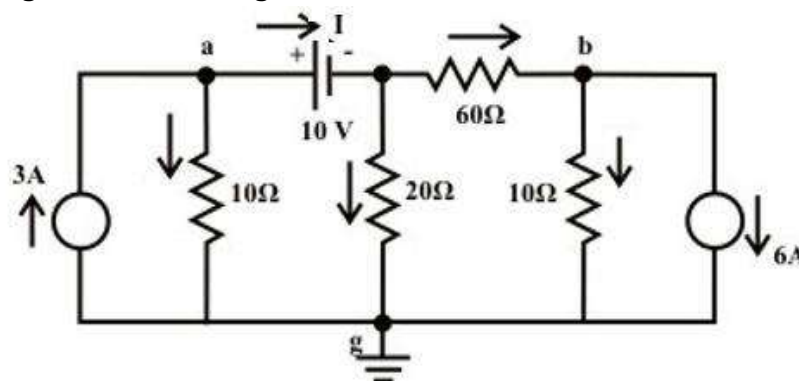

Solution: All nodes are indicated in fig. and 'Node-g' is selected as reference voltage. If a voltage source is connected directly between the two nodes, the current flowing through the voltage source cannot be determined directly since the source voltage V_S is independent of current. Further to note that the source voltage V_S fixes the voltage between the nodes only. For the present example, the voltage of the central node is known since it is equal to $(V_a - 10)$ volt.

KCL equation at node-a:

$$3 = \frac{V_a - 0}{10} + I \rightarrow 10I + V_a = 30 \quad (1)$$

KCL equation at node-b:

$$\frac{(V_a - 10) - V_b}{60} = 6 + \frac{V_b - 0}{10} \rightarrow V_a - 7V_b = 370 \quad (2)$$

To solve the equations (1)-(4), we need one more equation which can be obtained by applying KCL at the central node (note central node voltage is $(V_a - 10)$).

$$I = \frac{V_a - 10}{20} + \frac{(V_a - 10) - V_b}{60} \rightarrow 60I = 4V_a - V_b - 40 \rightarrow I = \frac{(4V_a - V_b - 40)}{60} \quad (3)$$

Substituting the current expression (3) in equation (1) we get,

$$\frac{(4V_a - V_b - 40)}{6} + V_a = 30 \rightarrow 10V_a - V_b = 220 \quad (4)$$

Equations (2) and (4) can be solved to find $V_b = -50.43V$ and $V_a = 16.99V$.

We can now refer to original circuit (fig.) to find directly the voltage across every element and the current through every element. The value of current flowing through the voltage source can be computed using the equation (3) and it is given by $I = 1.307A$.

Note that the current I (+ve) is entering through the positive terminal of the voltage source and this indicates that the voltage source is absorbing the power, in other words this situation is observed when charging a battery or source.

8. **Star-Delta transformation:** Certain network configurations cannot be resolved by using series-parallel combinations alone. Such configurations are handled by star-Delta transformations.

Delta to Star Transformation:

If we want to transform delta connected network into star connected network, so we will have to calculate the values of star connected resistances in terms of delta connected resistances.

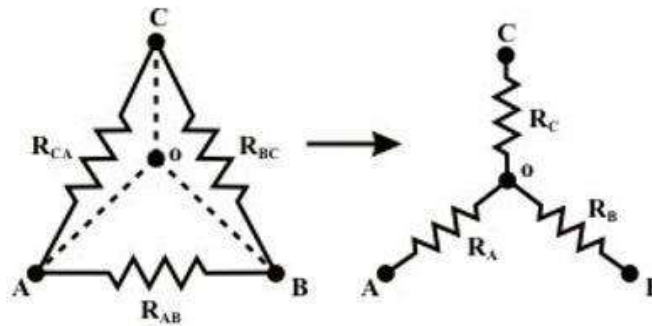

Let us consider the network shown in fig given above and assumed the resistances (R_{AB} , R_{BC} , and R_{CA}) in Δ network are known. Our problem is to find the values of R_A , R_B , and R_C in Wye (Y) network shown above that will produce the same resistance when measured between similar pairs of terminals. We can write the equivalence resistance between any two terminals in the following form.

Between A & C terminals:

$$R_A + R_C = \frac{R_{CA}(R_{AB} + R_{BC})}{R_{AB} + R_{BC} + R_{CA}} \quad (1)$$

Between C & B terminals:

$$R_C + R_B = \frac{R_{BA}(R_{AB} + R_{CA})}{R_{AB} + R_{BC} + R_{CA}} \quad (2)$$

Between B & A terminals:

$$R_B + R_A = \frac{R_{AB}(R_{CA} + R_{BC})}{R_{AB} + R_{BC} + R_{CA}} \quad (3)$$

By combining above three equations, one can write an expression as given below.

$$R_A + R_B + R_C = \frac{R_{AB}R_{BC} + R_{BC}R_{CA} + R_{CA}R_{AB}}{R_{AB} + R_{BC} + R_{CA}} \quad (4)$$

Subtracting equations (2), (1), and (3) from (4) equations, we can write the express for unknown resistances of Wye (Y) network as

$$R_A = \frac{R_{AB}R_{CA}}{R_{AB} + R_{BC} + R_{CA}} \quad (5)$$

$$R_B = \frac{R_{AB}R_{BC}}{R_{AB} + R_{BC} + R_{CA}} \quad (6)$$

$$R_C = \frac{R_{BC}R_{CA}}{R_{AB} + R_{BC} + R_{CA}} \quad (7)$$

Star to Delta Transformation:

If we want to transform star connected network into delta connected network, so we will have to calculate the values of delta connected resistances in terms of star connected resistances.

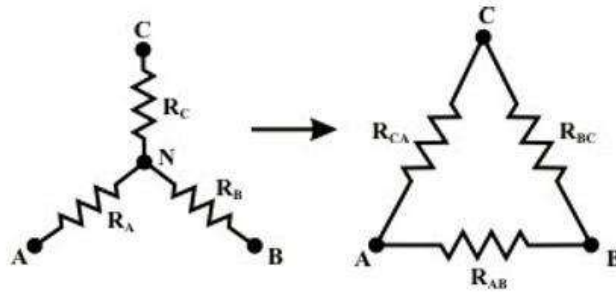

To convert a **Wye (Y)** to a **Delta (Δ)**, the relationships R_{AB} , R_{BC} , and R_{CA} must be obtained in terms of the **Wye (Y)** resistances R_A , R_B , and R_C shown in the above figure

Considering the **Y** connected network, we can write the current expression through R_A resistor as

$$I_A = \frac{(V_A - V_N)}{R_A} \quad (\text{for } Y \text{ network}) \quad (1)$$

Applying KCL at 'N' for **Y** connected network (assume A, B, C terminals having higher potential than the terminal N) we have,

$$\frac{(V_A - V_N)}{R_A} + \frac{(V_B - V_N)}{R_B} + \frac{(V_C - V_N)}{R_C} = 0 \Rightarrow V_N \left(\frac{1}{R_A} + \frac{1}{R_B} + \frac{1}{R_C} \right) = \left(\frac{V_A}{R_A} + \frac{V_B}{R_B} + \frac{V_C}{R_C} \right)$$

$$\text{or, } \Rightarrow V_N = \frac{\left(\frac{V_A}{R_A} + \frac{V_B}{R_B} + \frac{V_C}{R_C} \right)}{\left(\frac{1}{R_A} + \frac{1}{R_B} + \frac{1}{R_C} \right)} \quad (2)$$

For Δ -network

Current entering at terminal A = Current leaving the terminal 'A'

$$I_A = \frac{V_{AB}}{R_{AB}} + \frac{V_{AC}}{R_{AC}} \quad (\text{for } \Delta \text{ network}) \quad (3)$$

From equations (1) and (3),

$$\frac{(V_A - V_N)}{R_A} = \frac{V_{AB}}{R_{AB}} + \frac{V_{AC}}{R_{AC}}$$

Using the V_N expression in the above equation, we get

$$\frac{\left(V_A - \frac{\left(\frac{V_A}{R_A} + \frac{V_B}{R_B} + \frac{V_C}{R_C} \right)}{\left(\frac{1}{R_A} + \frac{1}{R_B} + \frac{1}{R_C} \right)} \right)}{R_A} = \frac{V_{AB}}{R_{AB}} + \frac{V_{AC}}{R_{AC}} \Rightarrow \frac{\left(\frac{V_A - V_B}{R_B} + \frac{V_A - V_C}{R_C} \right)}{\left(\frac{1}{R_A} + \frac{1}{R_B} + \frac{1}{R_C} \right)} = \frac{V_{AB}}{R_{AB}} + \frac{V_{AC}}{R_{AC}}$$

$$\text{or } \frac{\left(\frac{V_{AB} + V_{AC}}{R_B + R_C} \right)}{\left(\frac{1}{R_A} + \frac{1}{R_B} + \frac{1}{R_C} \right)} = \frac{V_{AB} + V_{AC}}{R_{AB} + R_{AC}} \quad (4)$$

Equating the coefficients of V_{AB} and V_{AC} in both sides of eq.(4), we obtained the following relationship.

$$\frac{1}{R_{AB}} = \frac{1}{R_A R_B \left(\frac{1}{R_A} + \frac{1}{R_B} + \frac{1}{R_C} \right)} \Rightarrow R_{AB} = R_A + R_B + \frac{R_A R_B}{R_C} \quad (5)$$

$$\frac{1}{R_{AC}} = \frac{1}{R_A R_C \left(\frac{1}{R_A} + \frac{1}{R_B} + \frac{1}{R_C} \right)} \Rightarrow R_{AC} = R_A + R_C + \frac{R_A R_C}{R_B} \quad (6)$$

Similarly, I_B for both the networks are given by

$$I_B = \frac{(V_B - V_N)}{R_B} \quad (\text{for } Y \text{ network})$$

$$I_B = \frac{V_{BC}}{R_{BC}} + \frac{V_{BA}}{R_{BA}} \quad (\text{for } \Delta \text{ network})$$

Equating the above two equations and using the value of V_N (see eq.(2)), we get the final expression as

$$\frac{\left(\frac{V_{BC} + V_{BA}}{R_C + R_A} \right)}{\left(\frac{1}{R_A} + \frac{1}{R_B} + \frac{1}{R_C} \right)} = \frac{V_{BC} + V_{BA}}{R_{BC} + R_{BA}}$$

Equating the coefficient of V_{BC} in both sides of the above equations we obtain the following relation

$$\frac{1}{R_{BC}} = \frac{1}{R_B R_C \left(\frac{1}{R_A} + \frac{1}{R_B} + \frac{1}{R_C} \right)} \Rightarrow R_{BC} = R_B + R_C + \frac{R_B R_C}{R_A} \quad (7)$$

9. Network Theorems: Network theorems are used to solve the electrical circuit problems. There are several types of network theorems, but only three theorems are in this course. These theorems are as follows:

1. Superposition Theorem
2. Thevenin's Theorem
3. Norton's Theorem

1. Superposition Theorem: The theorem states that, " In any multisource complex network consisting of linear, bilateral elements, the voltage across or current through any given element of the network is equal to the algebraic sum of the individual voltage or currents produced independently across or in that element

by each source acting independently, when all the remaining sources are replaced by their internal resistances.

Procedure: Consider for an electrical network having several independent energy sources are present, so to find the current through a particular branch or voltage across that branch, following steps are used:

Step 1: Consider one source at a time and eliminate other sources from the circuit (voltage and current sources are replaced by their respective internal resistances respectively)

Step 2: Calculate the current through or voltage across the particular element.

Step 3: Repeat the same procedure for all the other energy sources.

Step 4: Take the algebraic sum of individual effects produced by individual sources to obtain the total current in or voltage across the element.

Example 3: Consider the network shown in given fig. Calculate current () and voltage () using superposition theorem.

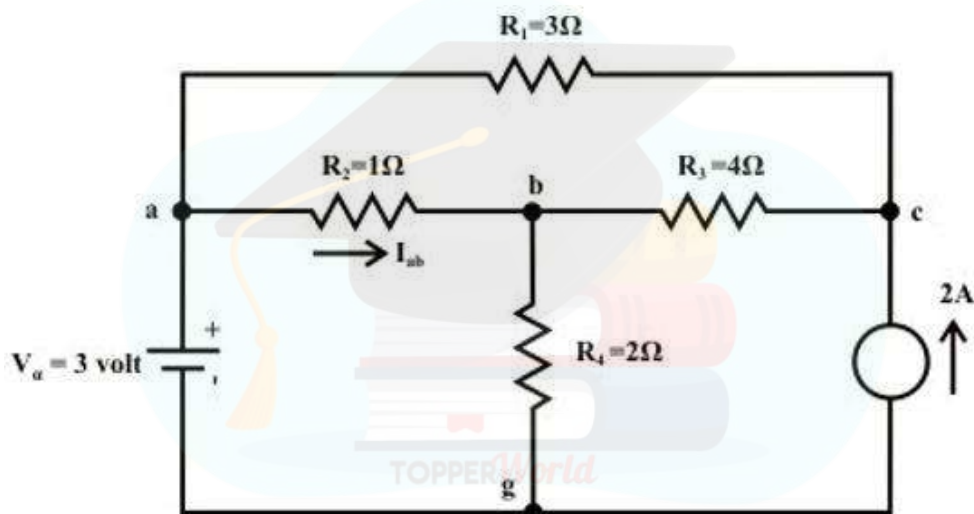

Solution: Voltage Source Only (retain one source at a time):

First consider the voltage source V_a that acts only in the circuit and the current source is replaced by its internal resistance (in this case internal resistance is infinite (∞)). The corresponding circuit diagram is shown in fig. and calculate the current flowing through the 'a-b' branch.

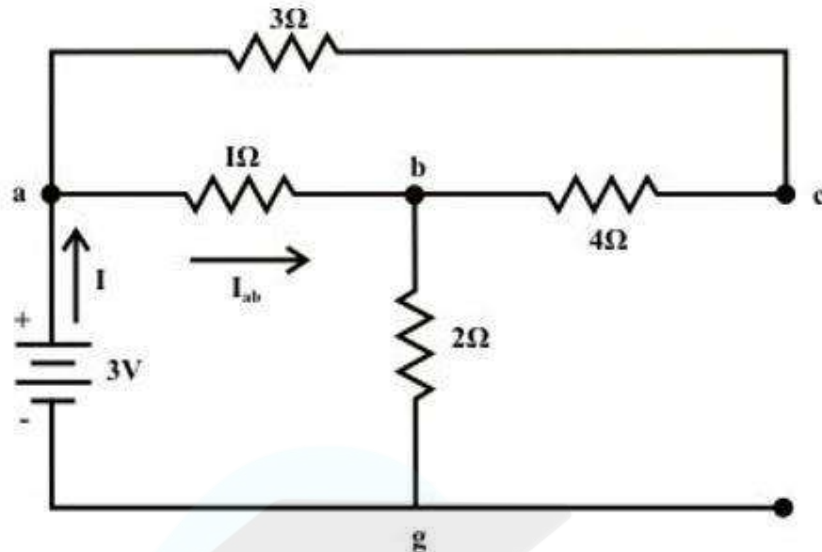

$$R_{eq} = [(R_{ac} + R_{cb}) \parallel R_{ab}] + R_{bg} = \frac{7}{8} + 2 = \frac{23}{8} \Omega$$

$$I = \frac{3}{\frac{23}{8}} A = 1.043A; \quad \text{Now current through a to b, is given by}$$

$$I_{ab} = \frac{7}{8} \times \frac{24}{23} = 0.913A \quad (\text{a to b})$$

$$I_{acb} = 1.043 - 0.913 = 0.13A$$

Voltage across c-g terminal :

$V_{cg} = V_{bg} + V_{cb} = 2 \times 1.043 + 4 \times 0.13 = 2.61 \text{volts}$ (Note: we are moving opposite to the direction of current flow and this indicates there is rise in potential). Note 'c' is higher potential than 'g'.

Current source only (retain one source at a time):

Now consider the current source $I_s = 2A$ only and the voltage source V_a is replaced by its internal resistance which is zero in the present case. The corresponding the simplified circuit diagram is shown below

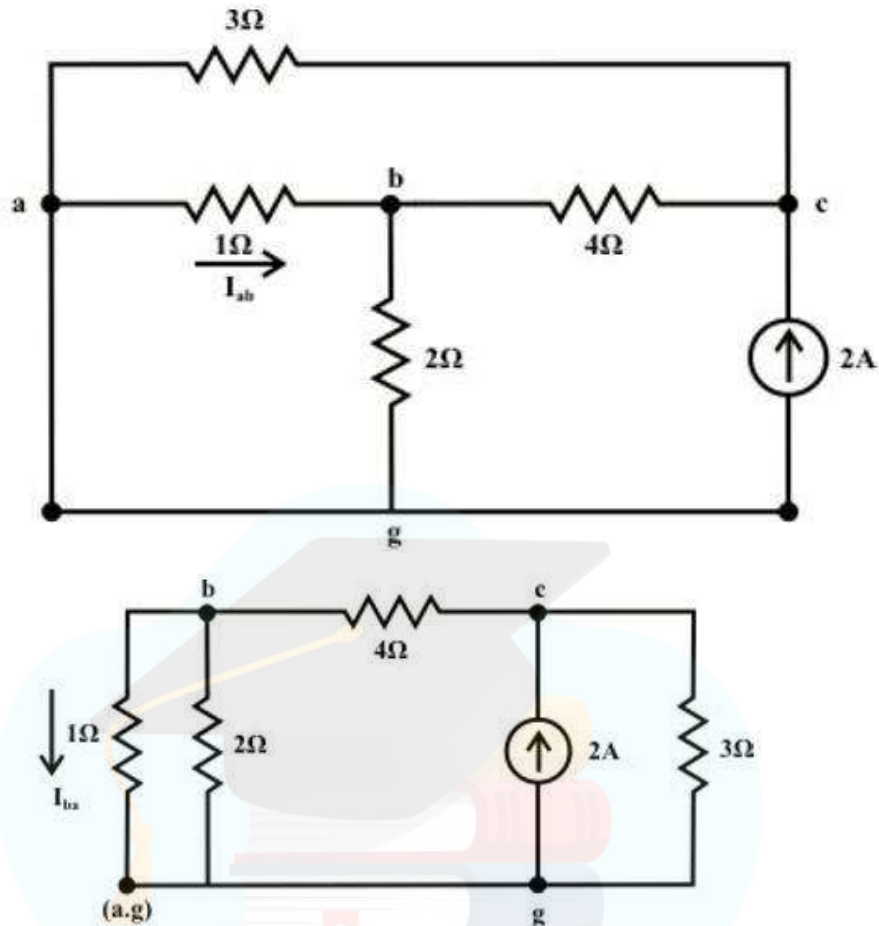

Current in the following branches:

$$3\Omega \text{ resistor} = \frac{(14/3) \times 2}{(14/3) + 3} = 1.217A; \quad 4\Omega \text{ resistor} = 2 - 1.217 = 0.783A$$

$$1\Omega \text{ resistor} = \left(\frac{2}{3}\right) \times 0.783 = 0.522A \text{ (b to a)}$$

$$\text{Voltage across } 3\Omega \text{ resistor (c \& g terminals)} V_{cg} = 1.217 \times 3 = 3.651 \text{ volts}$$

The total current flowing through 1Ω resistor (due to the both sources) from a to b = 0.913 (due to voltage source only; current flowing from 'a' to 'b') - 0.522 (due to current source only; current flowing from 'b' to 'a') = $0.391A$.

Total voltage across the current source $V_{cg} = 2.61 \text{ volt}$ (due to voltage source; 'c' is higher potential than 'g') + 3.651 volt (due to current source only; 'c' is higher potential than 'g') = 6.26 volt .

2. Thevenin's Theorem: This theorem states that, "The current flowing through a load resistance connected across any two terminals A and B of a linear, active and bilateral network is given by $I = \frac{V}{R + r}$ where V is the open circuit voltage (i.e. voltage across the two terminals when load is removed) and r is the internal resistance of the

network as viewed back into the open circuited network from terminals A and B with all energy sources are replaced by their internal resistances”.

Procedure: Consider an electrical circuit in which we have to find the current through its branch. So, step wise procedure is as follows:

Step 1: Remove the branch through which current or across which voltage has to find and redraw the circuit.

Step 2: Calculation of Thevenin’s Resistance () – Remove all the energy sources from the circuit (All energy sources are replaced by their internal resistances) drawn in step 1 and calculate the equivalent resistance of the circuit as viewed back into the open circuited network from terminals A and B.

Step 3: Calculation of Thevenin’s Voltage () – Redraw the circuit of step 1 and find the open circuit voltage by using mesh analysis or any other suitable method.

Step 4: Draw Thevenin’s equivalent circuit and connect the load resistance across A and B terminals of Thevenin’s equivalent circuit.

Step 5: Calculate the current flowing through the load resistance using the following formula:
$$I = \frac{V_{th}}{R_{th} + R_L} \quad (i)$$

Example 4: For the circuit shown in given fig., find the current through 6 Ω resistor using Thevenin’s theorem.

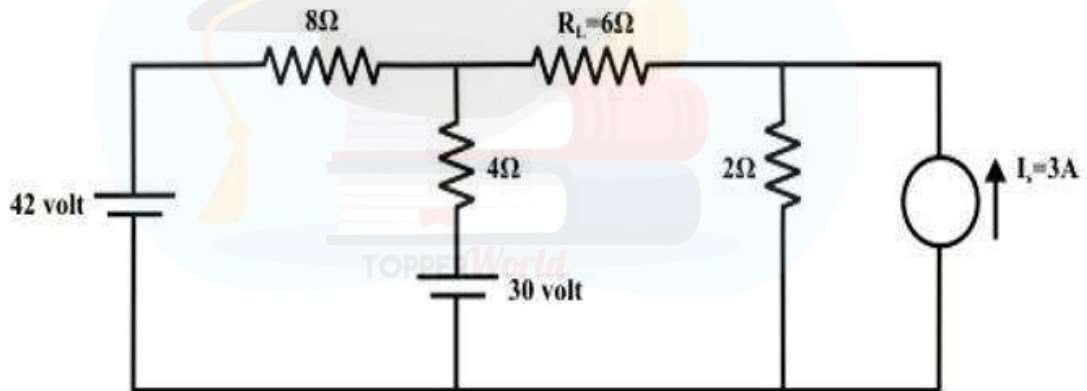

Solution:

Step-1: Disconnect 6Ω from the terminals ‘a’ and ‘b’ and the corresponding circuit diagram is shown in fig.below . Consider point ‘g’ as ground potential and other voltages are measured with respect to this point.

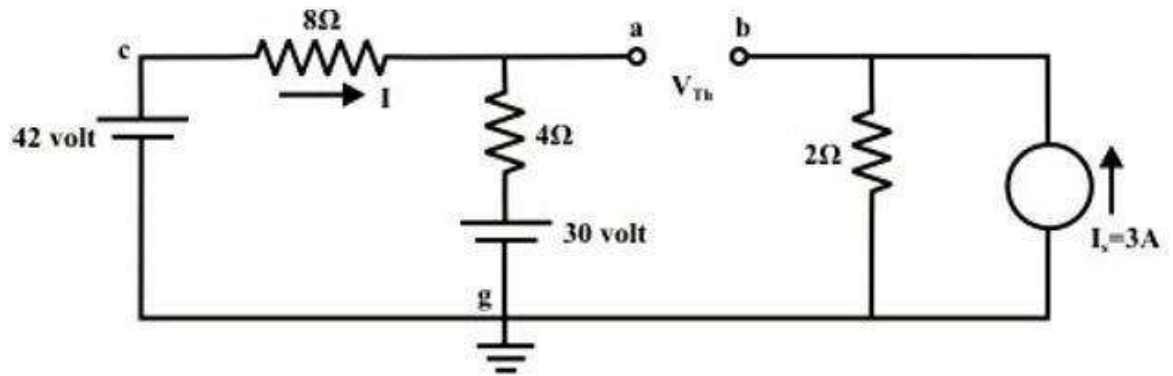

Step-2: Apply any suitable method to find the Thevenin's voltage (V_{Th}) (or potential between the terminals 'a' and 'b'). KVL is applied around the closed path 'gcag' to compute Thevenin's voltage.

$$42 - 8I - 4I - 30 = 0 \Rightarrow I = 1A$$

$$\text{Now, } V_{ag} = 30 + 4 = 34 \text{ volt; } V_{bg} = 2 \times 3 = 6 \text{ volt.}$$

$$V_{Th} = V_{ab} = V_{ag} - V_{bg} = 34 - 6 = 28 \text{ volt (note 'a' is higher potential than 'b')}$$

Step-3: Thevenin's resistance R_{Th} can be found by replacing all sources by their internal resistances (all voltage sources are short-circuited and current sources are just removed or open circuited) as shown in fig. below.

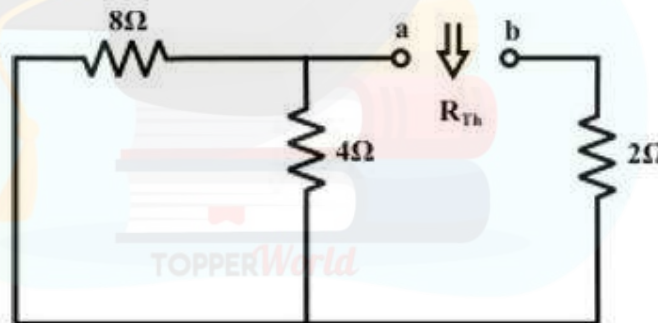

$$R_{Th} = (8 \parallel 4) + 2 = \frac{8 \times 4}{12} + 2 = \frac{14}{3} = 4.666 \Omega$$

Step-4: Thevenin's equivalent circuit as shown in fig. below is now equivalently represents the original circuit

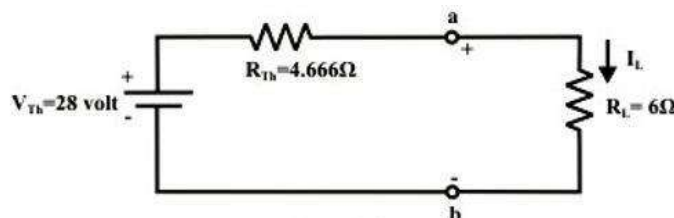

$$I_L = \frac{V_{Th}}{R_{Th} + R_L} = \frac{28}{4.666 + 6} = 2.625 A$$

3. Norton's Theorem: This theorem states that, " Any two terminal active network containing energy sources and resistance when viewed from its output terminals, is equivalent to a constant current source and a parallel resistance. The constant current is equal to the current which would flow in a short circuit placed across the terminals and parallel resistance is the resistance of the network when viewed from these open circuited terminals after all energy sources have been removed and replaced by their internal resistances".

Procedure: Consider an electrical circuit in which we have to find the current through its branch. So, step wise procedure is as follows:

Step 1: Remove the branch through which current or across which voltage has to find and redraw the circuit.

Step 2: Calculation of Norton's Resistance () – Remove all the energy sources from the circuit (All energy sources are replaced by their internal resistances)

drawn in step 1 and calculate the equivalent resistance of the circuit as viewed back into the open circuited network from terminals A and B.

Step 3: Calculation of Norton's Current () – Redraw the circuit of step 1 and find the short circuit current by using mesh analysis or any other suitable method.

Step 4: Draw Norton's equivalent circuit and connect the load resistance across A and B terminals of Norton's equivalent circuit.

Step 5: Calculate the current flowing through the load resistance using the following formula:
$$I = \frac{V_N}{R_N + R_L} \quad (i)$$

Example 5: For the circuit shown in the given fig., find the current through $R_L = 2\Omega$ resistor (branch) using Norton's theorem & hence calculate the voltage across the current source ().

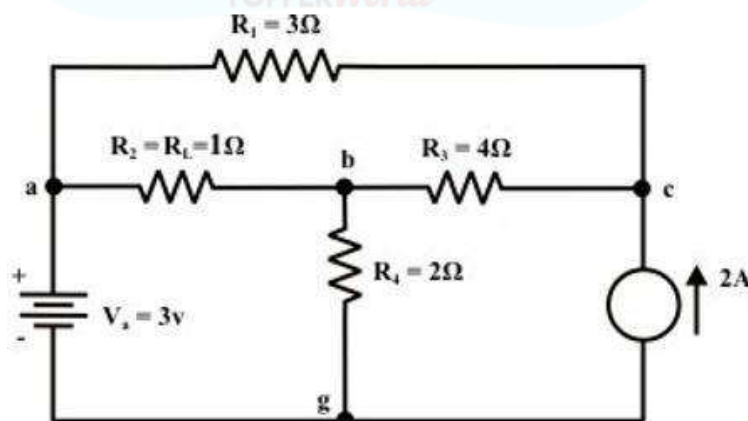

Solution:

Step-1: Remove the resistor through which the current is to be found and short the terminals 'a' and 'b'

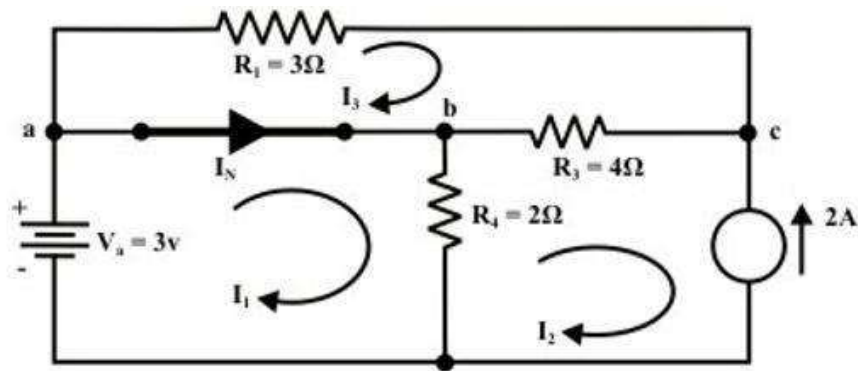

Step-2: Any method can be adopted to compute the current flowing through the a-b branch. Here, we apply 'mesh - current' method.

Loop-1

$$3 - R_4(I_1 - I_2) = 0, \text{ where } I_2 = -2A$$

$$R_4 I_1 = 3 + R_4 I_2 = 3 - 2 \times 2 = -1 \quad \therefore I_1 = -0.5A$$

Loop-3

$$-R_1 I_3 - R_3(I_3 - I_2) = 0$$

$$-3I_3 - 4(I_3 + 2) = 0$$

$$-7I_3 - 8 = 0$$

$$I_3 = -\frac{8}{7}$$

$$\begin{aligned} \therefore I_N &= (I_1 - I_3) = \left(-0.5 + \frac{8}{7}\right) = \frac{-7+16}{14} \\ &= \frac{9}{14} \text{ A (current is flowing from 'a' to 'b')} \end{aligned}$$

Step-3: To compute R_N , all sources are replaced with their internal resistances. The equivalent resistance between 'a' and 'b' terminals is same as the value of Thevenin's resistance of the circuit shown in fig. below.

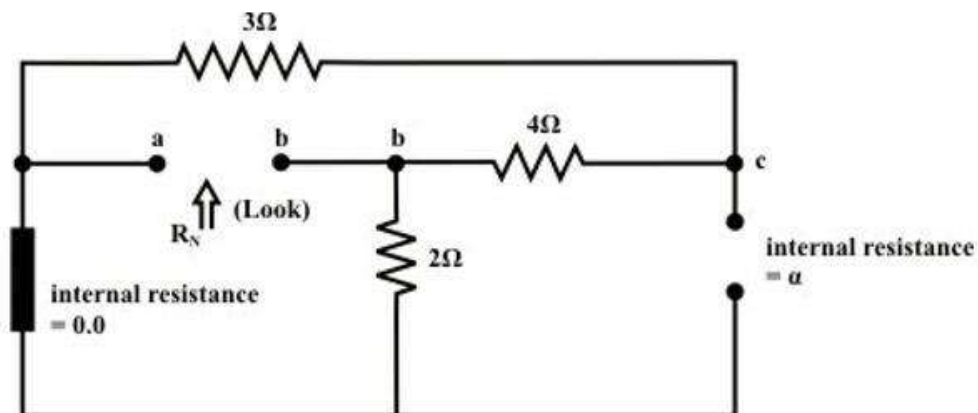

Step-4: Replace the original circuit with an equivalent Norton's circuit as shown in fig.

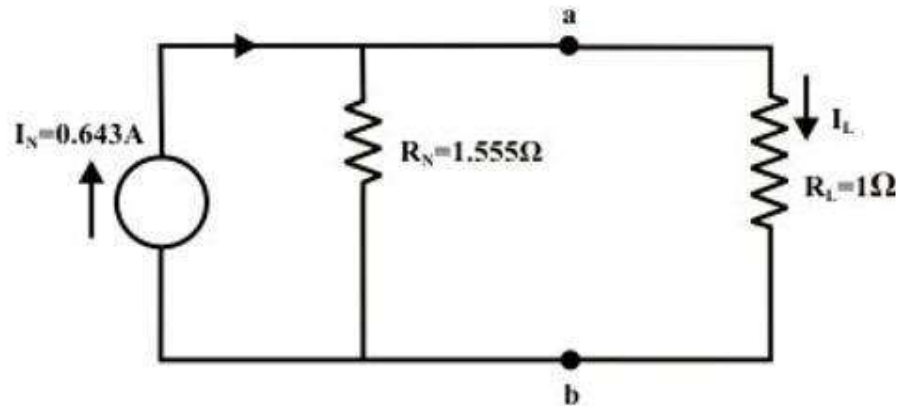

$$I_L = \frac{R_N}{R_N + R_L} \times I_N = \frac{1.555}{1.555 + 1} \times 0.643 = 0.39\text{A (a to b)}$$



Module - 2: Steady- State Analysis of Single Phase AC Circuits:

Contents: Representation of Sinusoidal waveforms – Average and effective values, Form and peak factors, Concept of phasors, phasor representation of sinusoidally varying voltage and current. Analysis of single phase AC Circuits consisting of R, L, C, RL, RC, RLC combinations (Series and Parallel), Apparent, active & reactive power, Power factor, power factor improvement. Concept of Resonance in series & parallel circuits, bandwidth and quality factor. Three phase balanced circuits, voltage and current relations in star and delta connections.

UNIT 2

Representation of Sinusoidal Waveform :

A sinusoidal quantity of current represented by $i(t) = I_{\max}\sin\omega t$ is taken up as an example. The length, OP, along the x-axis, represents the maximum value of the current, on a certain scale. It is being rotated in the anti-clockwise direction at an angular speed, ω , and takes up a position, OA after a time t (or angle, $\omega t = \theta$, with the x-axis). The vertical projection of OA is plotted in the right hand side of the above figure with respect to the angle θ . It will generate a sine wave, as OA at an angle, θ with the x-axis, as stated earlier. The vertical projection of OA along y-axis is $OC = AB$.

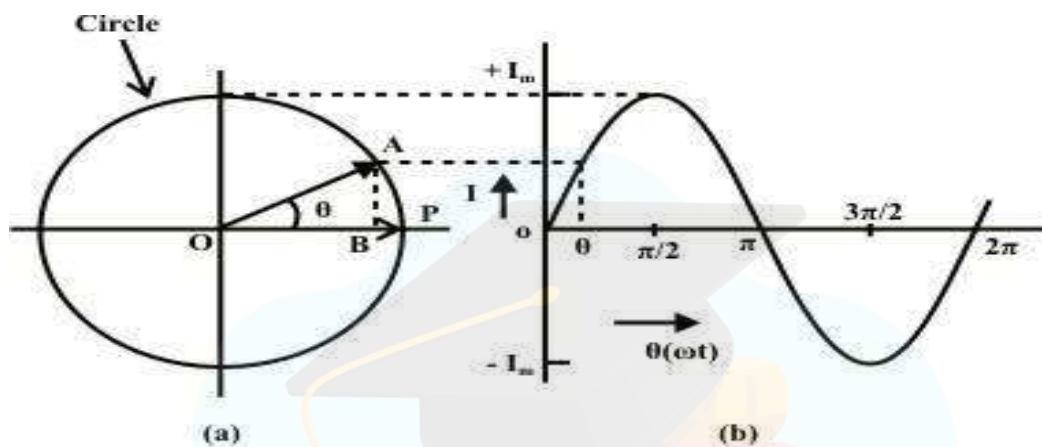

Figure 1

The value of current $i = I_{\max}\sin\theta$ which is the instantaneous value of the current at any time t or angle θ . The angle θ is in rad., i.e. $t\omega = \theta$. The angular speed, ω is in rad/s, i.e. $\omega = 2\pi f$, where f is the frequency in Hz or cycles/sec. Thus, $i = I_{\max}\sin\omega t = I_{\max}\sin(2\pi f)t$

So, OP represents the phasor with respect to the above current, i .

The line, OP can be taken as the rms value, $I_{RMS} = I_{MAX} / \sqrt{2}$.

Then the vertical projection of OA, in magnitude equal to OP, does not represent exactly the instantaneous value of I , but represents it with the scale factor of $1/\sqrt{2} = 0.707$.

The movement of phasor in anticlockwise direction with respect to ω traces the sinusoidal waveform as shown in the figure above.

AVERAGE VALUE

The voltage waveform shown here is periodic in nature with the time period, T . It is positive for first half and negative for second half. The average value of the waveform $v(t) = V_{\max}\sin\omega t$ is defined as

$$V_{av} = \frac{\text{Area over half cycle}}{\text{Time period of half cycle}} = \frac{1}{T/2} \int_0^{T/2} v(t) dt = 0.637V_{\max}$$

Here, average is taken out only for one alternation because average for a complete cycle in an AC system will be equal to zero. This can be shown in the figure below: $V_{av} =$

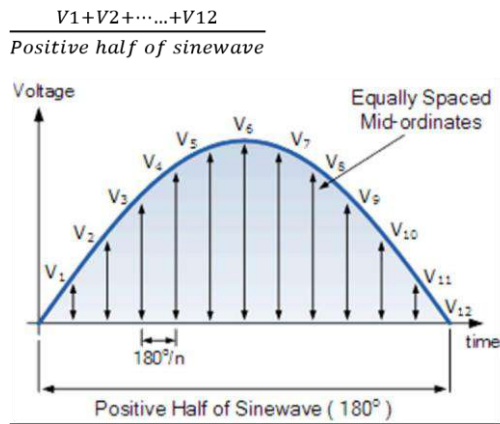

Figure 2

ROOT MEAN SQUARE VALUE (RMS):

RMS stands for Root Mean Square, and is a way of expressing an AC quantity of voltage or current in terms functionally equivalent to DC. Also known as the “equivalent” or “DC equivalent” value of an AC voltage or current. For a sine wave, the RMS value is approximately 0.707 of its peak value.

$$V_{rms} = \frac{\text{Area over half cycle}}{\text{Time period of half cycle}} = \frac{1}{T/2} \sqrt{\int_0^{T/2} v(t)^2 dt}$$

when calculated for a voltage equation of $v = V_{max} \sin \omega t$, where $\omega = 2\pi f$. When frequency, $f = 50\text{Hz}$, ω becomes $100\pi = 314\text{rad/sec}$.

Using values of v , ω in V_{rms} . We get $V_{rms} = V_{max}/\text{sqrt}(2)$.

The final conclusion about Average value, RMS value can be illustrated in the figure below:

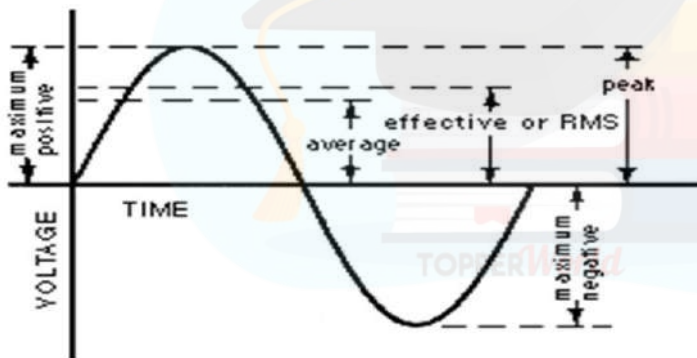

Figure 3

FORM FACTOR: Form factor is the ratio between RMS value and Average value. It can be represented as: Form factor =

For a sinusoidal signal, form factor is $FF = \frac{V_{rms}}{V_{avg}} = 1.11$

PEAK FACTOR: Peak factor is the ratio between Maximum value and Average value. It can be represented as: Peak $\frac{\text{MAX VALUE}}{\text{AVERAGE VALUE}}$ factor = For a sinusoidal signal, peak factor is $PF = \frac{V_{max}}{V_{avg}} = 1.14$

CONCEPT OF PHASOR

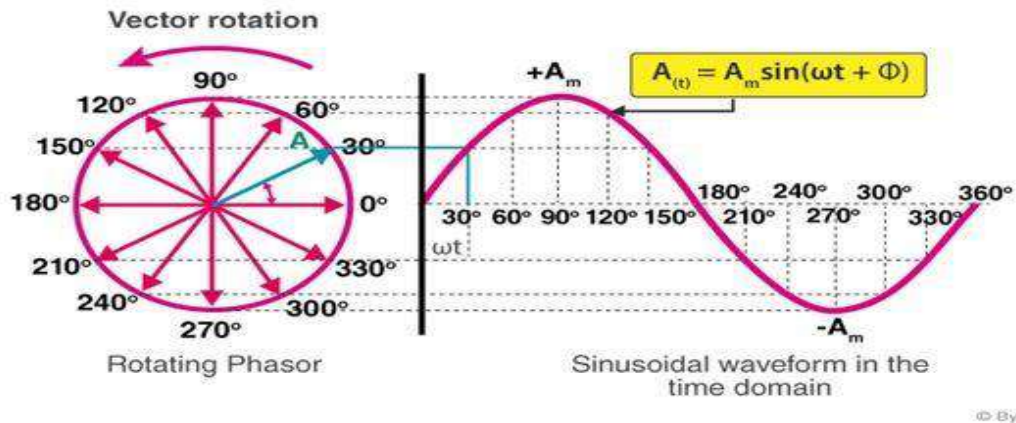

Figure 4

Phasor is a rotating vector. If it is rotating in anti clockwise direction then the angle is considered positive. If vector is rotating in clockwise direction then the angle is considered negative. As shown in figure above, Phasor A indicated by blue color will be denoted by $A = A \angle 30^\circ$. Every phasor consist of magnitude $|A|$ and angle.

We check for lagging and leading condition by comparing with reference or zero degree. In the figure shown above, phasor A is leading from reference by 30° .

PHASOR REPRESENTATION OF SINUSOIDALLY VARYING VOLTAGE AND CURRENT

The frequency with which any vector is rotating is taken as frequency, f . From frequency, f we get angular frequency, ω which is equal to $2\pi f$. For representing voltage and current we should check the nature of waveform whether it is sinusoidal or cosinusoidal or any other type of waveform.

If we have a general case of sinusoidal waveform then voltage waveform will be represented as $v = V_{\max} \sin(\omega t \pm \theta)$

Here \pm indicates whether angle is in positive quadrant or negative quadrant or in other words whether it is lagging or leading with respect to reference. Similarly current will be represented as $i = I_{\max} \sin(\omega t \pm \theta)$. Angle, θ represents the voltage or current.

PHASOR ALGEBRA

Before discussing the mathematical operations, like addition/subtraction and multiplication/division, involving phasors and also complex quantities, let us take a look at the several forms by which a phasor or complex quantity

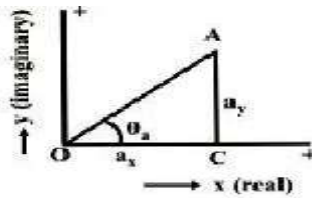

is represented.

Figure 5

Any phasor can be represented in four forms: (a) Rectangular form or symbolic form (b) Polar form (c) Trigonometric form (d) Exponential form

- a) Rectangular form: Phasor is represented in two components of x-axis and y-axis. Since the angle between x-axis and y-axis is 90° , we represent it by 'j'. In Figure 5, phasor $OA = a_x + ja_y$.
- b) Polar form: Phasor is represented by resolving it on x-axis and y-axis with trigonometric function like

$$a_x = OA \cos \theta_a \text{ and } a_y = OA \sin \theta_a. \text{ Phasor } OA = \sqrt{a_x^2 + a_y^2} \angle \tan^{-1}\left(\frac{a_y}{a_x}\right) = OA \angle \tan^{-1}\left(\frac{a_y}{a_x}\right) = OA \angle \phi$$

- c) Trigonometric form: Here, rectangular form and polar form are utilized for representing OA,

$$OA = OA \cos \theta_a + jOA \sin \theta_a = OA(\cos \theta_a + j \sin \theta_a)$$

- d) Exponential form: Using Euler's form, $e^{jx} = \cos x + j \sin x$. Phasor OA is represented as

$$OA = |OA| e^{j\phi}$$

PHASOR ADDITION

Addition of two phasors is done easily in rectangular form or symbolic form.

$$\text{For phasors: } OA = a_x + ja_y \text{ and } OB = b_x + jb_y$$

$$OC = OA + OB = (a_x + b_x) + j(a_y + b_y)$$

PHASOR SUBTRACTION

Subtraction of two phasors is done easily in rectangular form or symbolic form.

$$\text{For phasors: } OA = a_x + ja_y \text{ and } OB = b_x + jb_y$$

$$OC = OA - OB = (a_x - b_x) + j(a_y - b_y)$$

PHASOR PRODUCT

Multiplication of two phasors is done easily in polar form.

$$\text{For phasors: } OA = OA \angle \phi \text{ and } OB = OB \angle \phi'$$

$$OC = (OA * OB) \angle (\phi + \phi')$$

PHASOR DIVISION

Division of two phasors is done easily in polar form

For phasors: $OA = OA \angle \phi$ and $OB = OB \angle \phi'$
 $OC = (OA/OB) \angle (\phi - \phi')$

ANALYSIS OF SINGLE PHASE AC CIRCUITS

1) Purely R Circuit

The instantaneous value of the current through the circuit is

$$i = v/R = V_{\max} \sin(\theta)/R = I_{\max} \sin(\theta) \quad \text{where,}$$

I_{\max} and V_{\max} are the maximum values of current and voltage respectively.

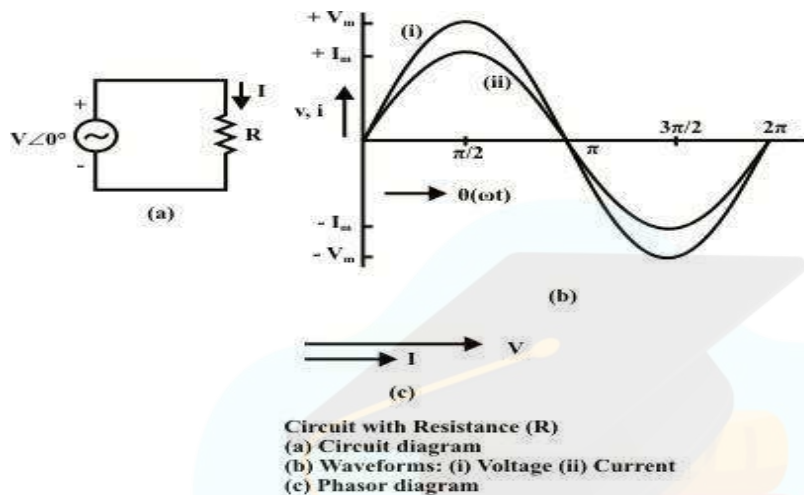

The RMS value of current is given by:

$$I_{\text{RMS}} = I_{\max}/\sqrt{2} = (V_{\max}/\sqrt{2})/R = V_{\text{RMS}}/R$$

The impedance or resistance of the circuit is obtained as,

$$V_{\text{RMS}}/I_{\text{RMS}} = R + j0$$

Please note that the voltage and the current are in phase ($\phi = 0^\circ$), which can be observed from phasor diagram with two (voltage and current) phasors, and also from the two waveforms.

In ac circuit, the term, Impedance is defined as voltage/current, as is the resistance in dc circuit, following Ohm's law. The impedance, Z is a complex quantity. It consists of real part as resistance R , and imaginary part as reactance X , which is zero, as there is no inductance/capacitance. All the components are taken as constant, having linear V-I characteristics. In the three cases being considered, including this one, the power consumed and also power factor in the circuits.

2) Purely L Circuit

The instantaneous value of the current and voltage through L circuit is

$$v = L di/dt = V_{\max} \sin \omega t = \sqrt{2} V_{\text{RMS}} \sin \omega t \quad (i)$$

$$di = \sqrt{2} V_{\text{RMS}} \sin \omega t dt / L \quad (ii)$$

Integrating (ii) we have, $i = -\left(\frac{V_{RMS}\sqrt{2}}{\omega L}\right)\text{Cos}\omega t = \left(\frac{\sqrt{2}V_{RMS}}{\omega L}\right)\text{Sin}(\omega t - 90^\circ) = I_{max}\text{Sin}(\omega t - 90^\circ)$ (iii)

Comparing (i) and (iii) gives the phase difference of 90° .

When we draw phasor diagram between voltage and current then we find that voltage is at 0° and current is at -90° . In case of inductor, current is lagging voltage by 90° .

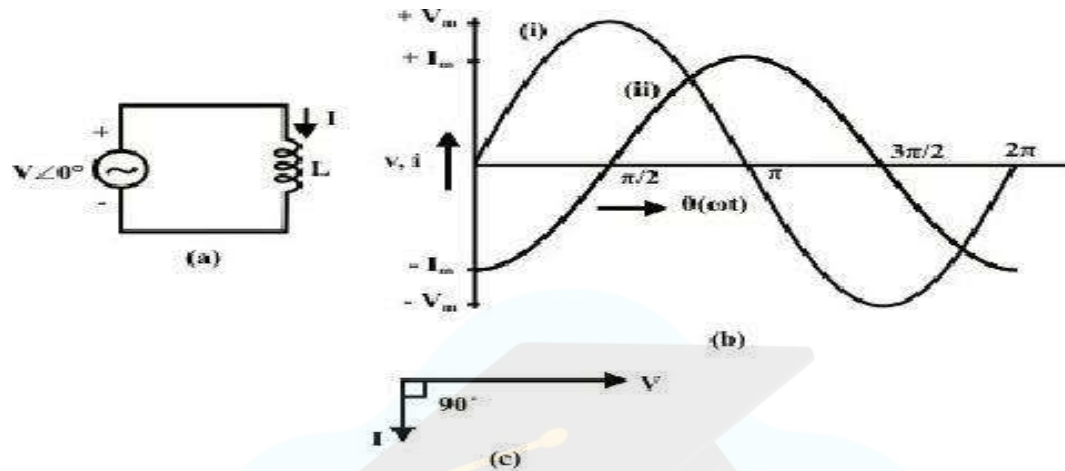

Circuit with Inductance (L)
 (a) Circuit diagram
 (b) Waveforms: (i) Voltage (ii) Current
 (c) Phasor diagram

3) Purely C Circuit

The instantaneous value of the current and voltage through C circuit is

$$i = Cdv/dt = CV_{max} d(\text{Sin}\omega t)/dt = \sqrt{2}\omega V_{RMS} d(\text{Sin}\omega t) / dt \quad (i)$$

$$i = \sqrt{2}\omega CV_{RMS}\text{Cos}\omega t \quad (ii)$$

Integrating (ii) we have, $i = \left(\frac{V_{RMS}\sqrt{2}}{1}\right) C\omega\text{Cos}\omega t = \left(\frac{V_{RMS}\sqrt{2}}{1}\right) C\omega\text{Sin}(\omega t + 90^\circ) = I_{max}\text{Sin}(\omega t + 90^\circ)$

(iii)

Comparing (i) and (iii) gives the phase difference of 90° .

When we draw phasor diagram between voltage and current then we find that voltage is at 0° and current is at $+90^\circ$. In case of capacitor, current is leading voltage by 90° .

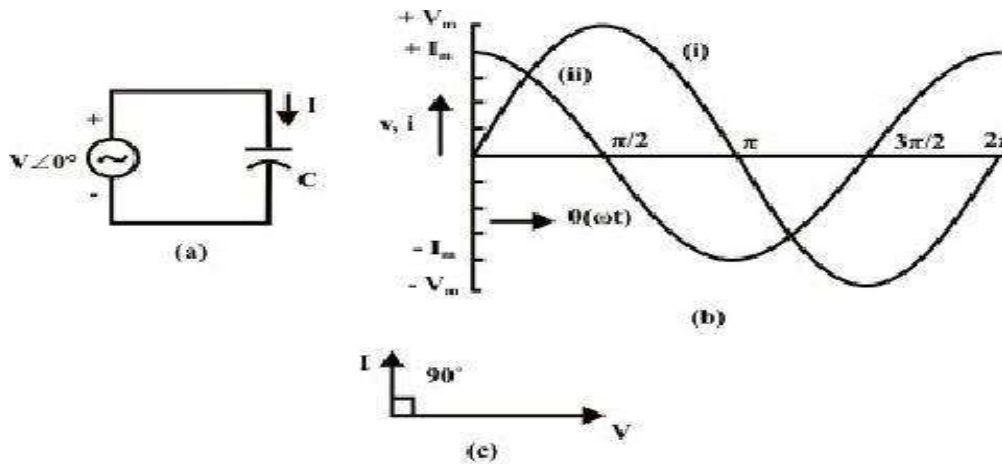

Circuit with Capacitance (C)
 (a) Circuit diagram
 (b) Waveforms: (i) Voltage (ii) Current
 (c) Phasor diagram

4) RLC Circuit (Series circuit)

The voltage balance equation is given by $v = iR + L \frac{di}{dt} + \int i dt$ (a)

As it is a series circuit, same current will be flowing through all the passive elements.

Equation (a) can be written as $v = V_R + V_L + V_C$

As discussed earlier current and voltage relationship in case of V_R i.e. resistor will be in phase. For V_L , current will lag behind voltage for inductor by 90° and current will lead voltage by 90° in case of capacitor.

The current involved will be of form, $i = I_{max} \sin(\omega t \pm \phi)$. This $\pm \phi$ will depend on the values of inductor and capacitor. $I = v/Z$. Here, Z represents Impedance of series AC circuit, Z is a phasor with magnitude and angle. Magnitude of $Z = \sqrt{R^2 + (X_L - X_C)^2}$

And angle of Z is = _____

Its SI unit is ohm.

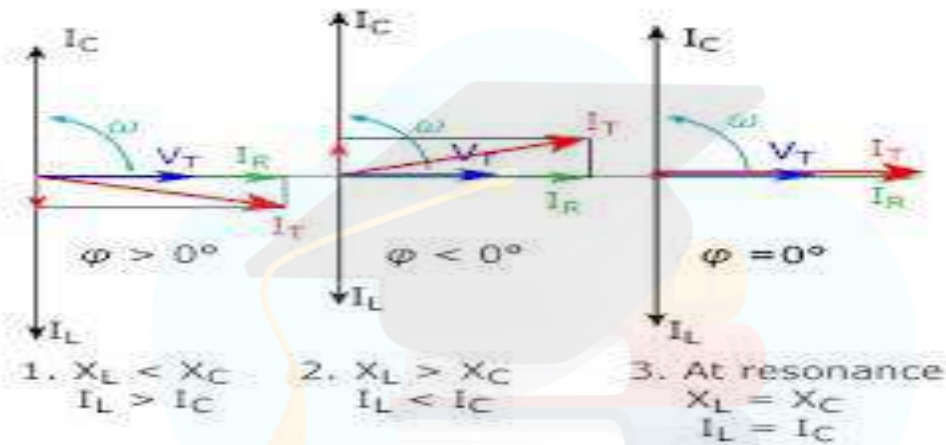
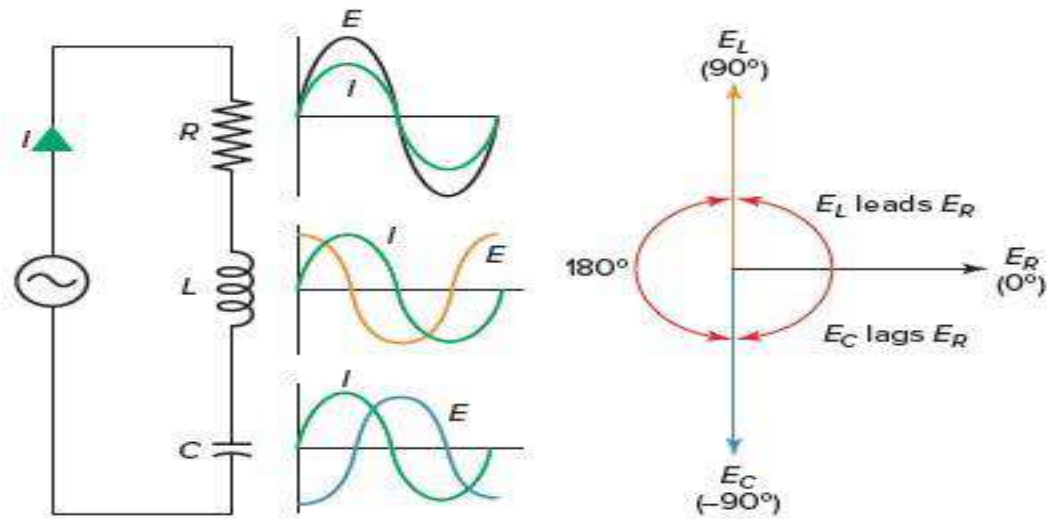

POWER FACTOR ANGLE : It is the angle between supply voltage and current. In the figure shown above it is denoted by ϕ .

POWER FACTOR : The cosine of the angle between voltage and current is called power factor. Mathematically, $\cos \phi$ is the power factor. As shown in the figure below, ϕ is also the angle between Z and R .

Impedance Triangle

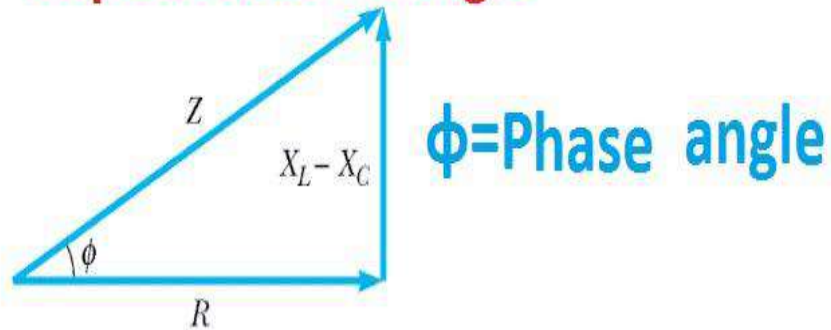

Z=Impedance

X_L =Inductive Reactance

R=Resistance

X_C = Capacitive Reactance

There will be three cases:

- a) $X_L > X_C$: Here Inductive reactance is greater than Capacitive reactance. In this case current will be lagging voltage. Equation of current will be, $i = I_{\max} \sin(\omega t - \phi)$. The main supply voltage, V_s will be inclined towards V_L instead of V_C . All the additions shown in the figure below will be phasor addition only.
- b) $X_C > X_L$: Here Capacitive reactance is greater than Inductive reactance. In this case current will be leading voltage. Equation of current will be, $i = I_{\max} \sin(\omega t + \phi)$. The main supply voltage, V_s will be inclined towards V_C instead of V_L .
- c) $X_L = X_C$ (**SERIES RESONANCE**): Here Inductive reactance is equal to Capacitive reactance. This is condition of **series or voltage resonance**. This is called voltage resonance because imaginary component of voltage will cancel out each other, i.e. $V_L = V_C$. Under this condition circuit will exhibit following properties:
 - (i) Impedance, $Z = \text{Resistance}, R$.
 - (ii) $I X_L = I X_C$
 - (iii) Power factor = 1 as power factor angle, $\phi = 0^\circ$
 - (iv) $\tan \phi = 0^\circ$
 - (v) Current will be maximum because impedance is equal to resistance.
 - (vi) Impedance will be minimum.

(vii) Resonant Frequency = $f_r = \frac{1}{2\pi\sqrt{LC}}$

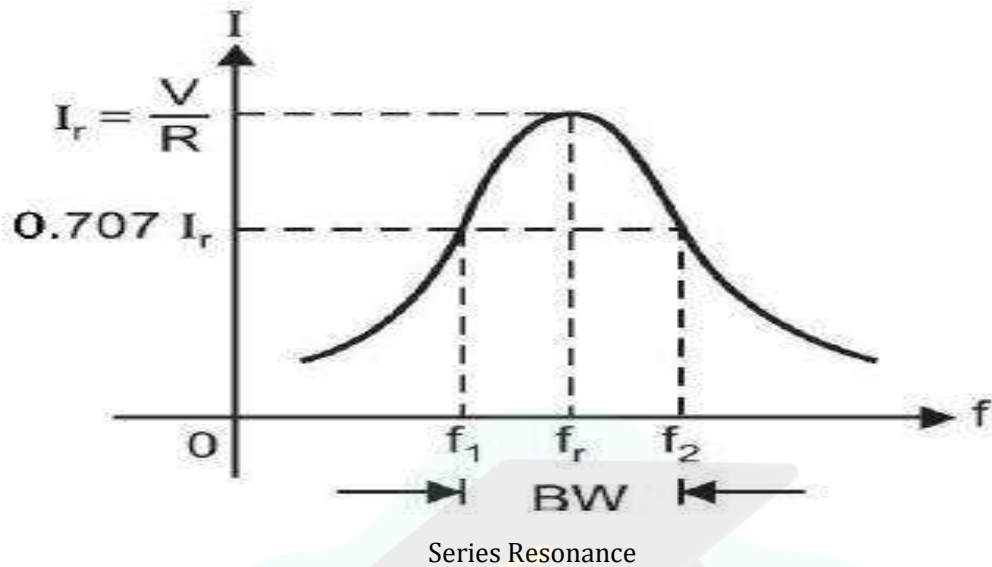

POWER TRIANGLE

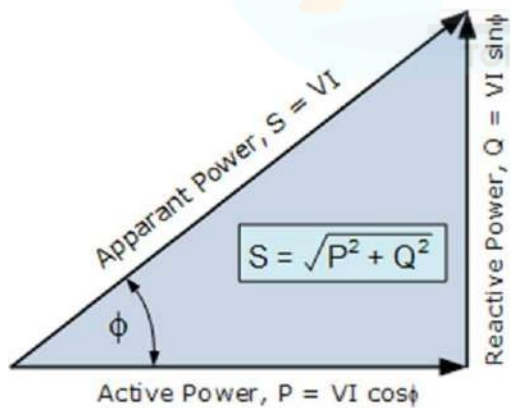

There are three types of power:

- 1) Active Power - It is also referred as real power . It acts along the resistive component of the circuit. It is denoted by Power $P = VI \cos \phi$ expressed in KW (kilo watt)

- 2) Reactive Power – It is also referred as imaginary power . It acts along the inductive and capacitive component of the circuit. It is denoted by Power $Q = VI \sin \phi$ expressed in KVAR (kilo volt ampere reactive).
- 3) Apparent Power – It is also referred as Total power . It is denoted by Power $S = VI$ expressed in KVA (kilo volt ampere).

POWER FACTOR IMPROVEMENT

The main cause of low Power factor is Inductive Load. As in pure inductive circuit, Current lags 90° from Voltage, this large difference of phase angle between current and voltage causes zero power factor. Basically, all those circuit having Capacitance and inductance (except resonance circuit (or Tune Circuit) where inductive reactance = capacitive reactance ($X_L = X_C$), so the circuit becomes a resistive circuit), power factor would be exist over there because Capacitance and inductance causes in difference of phase angle (θ) between current and voltage.

CAUSES OF LOW POWER FACTOR

1. Single phase and three phase induction Motors.

Usually, Induction motor works at poor power factor i.e. at: Full load, $Pf = 0.8 - 0.9$, Small load, $Pf = 0.2 - 0.3$, No Load, Pf may come to Zero (0).

2. Varying Load in Power System

As we know that load on power system is varying. During low load period, supply voltage is increased which increase the magnetizing current which cause the decreased power factor.

3. Industrial heating furnaces.
4. Electrical discharge lamps (High intensity discharge lighting) Arc lamps (operate at very low power factor)
5. Transformers
6. Harmonic Currents

Power factor play an important role in AC circuits and power dissipation depends on this factor. For instant, we know that; Power in a Three Phase AC Circuit = $P = \sqrt{3} V \times I \cos\Phi$

And Current in a Three Phase AC Circuits = $I = P / (\sqrt{3} V \times \cos\Phi)$

$$I \propto 1 / \cos\Phi \dots\dots (1)$$

Power in a Single Phase AC Circuits = $P = V \times I \cos\Phi$

And Current in a Three phase AC Circuits = $I = P / (V \times \cos\Phi)$

$$I \propto 1 / \cos\Phi \dots\dots (2)$$

It is clear from both equations (1) an (2) that Current "I" is inversely proportional to $\cos\Phi$ i.e. Power Factor. In other words, when power factor increases, Current Decreases, and when Power Factor decreases, Current Increases.

Now, In case of Low Power Factor, Current will be increased, and this high current will cause to the following disadvantages.

1.) Large Line Losses (Copper Losses):

We know that Line Losses is directly proportional to the square of Current " I^2 "

Power Loss = $I^2 \times R$ i.e., the larger the current, the greater the line losses i.e. $I \gg$ Line Losses.

Power Loss = $I^2 \times R = 1/\cos^2 \Phi$ Refer to Equation " $I \propto 1/\cos \Phi$ " (1)

Thus, if Power factor = 0.8, then losses on this power factor = $1/\cos^2 \Phi = 1/0.8^2 = 1.56$ times will be greater than losses on Unity power factor.

2.) Large kVA rating and Size of Electrical Equipments:

As we know that almost all Electrical Machinery (Transformer, Alternator, Switchgears etc) rated in kVA. But, it is clear from the following formula that Power factor is inversely proportional to the kVA i.e.

$$\cos \Phi = kW / kVA$$

Therefore, The Lower the Power factor, the larger the kVA rating of Machines also, the larger the kVA rating of Machines, The larger the Size of Machines and The Larger the size of Machines, The Larger the Cost of machines.

3.) Greater Conductor Size and Cost:

In case of low power factor, current will be increased, thus, to transmit this high current, we need the larger size of conductor. Also, the cost of large size of conductor will be increased.

4.) Poor Voltage Regulation and Large Voltage Drop:

Voltage Drop = $V = IZ$.

Now in case of Low Power factor, Current will be increased. So the Larger the current, the Larger the Voltage Drop.

Also Voltage Regulation = $V.R = (V_{No\ Load} - V_{Full\ Load}) / V_{Full\ Load}$

In case of Low Power Factor (lagging Power factor) there would be large voltage drop which cause low voltage regulation.

5.) Low Efficiency:

In case of low Power Factor, there would be large voltage drop and large line losses and this will cause the system or equipments efficiency too low. For instant, due to low power factor, there would be large line losses; therefore, alternator needs high excitation, thus, generation efficiency would be low.

POWER FACTOR IMPROVEMENT

The following devices and equipment are used for Power Factor Improvement.

1. Static Capacitor
2. Synchronous Condenser
3. Phase Advancer

1. Static Capacitor

For Power factor improvement purpose, Static capacitors are connected in parallel with those devices which work on low power factor. These static capacitors provides leading current

which neutralize (totally or approximately) the lagging inductive component of load current (i.e. leading component neutralize or eliminate the lagging component of load current) thus power factor of the load circuit is improved. These capacitors are installed in Vicinity of large inductive load e.g Induction motors and transformers etc, and improve the load circuit power factor to improve the system or devices efficiency.

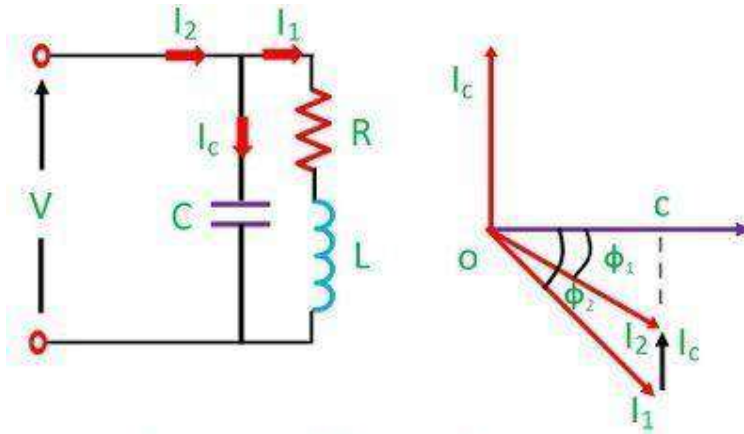

Circuit and Phasor diagram

Figure 1

Suppose, here is a single phase circuit where load is taking lagging current I_1 and the load power factor is $\cos\theta_1$ as shown in Fig-1.

When a Capacitor, C has been connected in parallel with load. Now a current I_c is flowing through Capacitor which lead 90° from the supply voltage. Note that Capacitor provides leading Current i.e. In a pure capacitive circuit, Current leading 90° from the supply Voltage, in other words, Voltage are 90° lagging from Current. The load current is I_1 . The Vectors combination of I_1 and I_c is I_2 .

It can be seen from figure that angle of $\Phi_2 > \Phi_1$ i.e. angle of Φ_2 is more than angle of Φ_1 . Therefore $\cos \Phi_2$ is less than from $\cos \Phi_1$ ($\cos \Phi_2 < \cos \Phi_1$). Hence the load power factor is improved by capacitor.

Also note that after the power factor improvement, the circuit current would be less than from the low power factor circuit current. Also, before and after the power factor improvement, the active component of current would be same in that circuit because capacitor eliminates only the reactive component of current. Also, the Active power (in Watts) would be same after and before power factor improvement.

2. Synchronous Condenser

When a Synchronous motor operates at No-Load and over-excited then it's called a synchronous Condenser. Whenever a Synchronous motor is over-excited then it provides leading current and works like a capacitor.

When a synchronous condenser is connected across supply voltage (in parallel) then it draws leading current and partially eliminates the re-active component and this way, power factor is improved. Generally, synchronous condenser is used to improve the power factor in large industries.

3. Phase Advancer

Phase advancer is a simple AC exciter which is connected on the main shaft of the motor and operates with the motor's rotor circuit for power factor improvement. Phase advancer is used to improve the power factor of induction motor in industries.

As the stator windings of induction motor takes lagging current 90° out of phase with voltage, therefore the power factor of induction motor is low. If the exciting ampere-turns are excited by external AC source, then there would be no effect of exciting current on stator windings. Therefore the power factor of induction motor will be improved. This process is done by Phase advancer.

PARALLEL RESONANCE IN PARALLEL CIRCUIT

Parallel resonance occur in parallel RLC circuit. This resonance is also referred to as antiresonance.

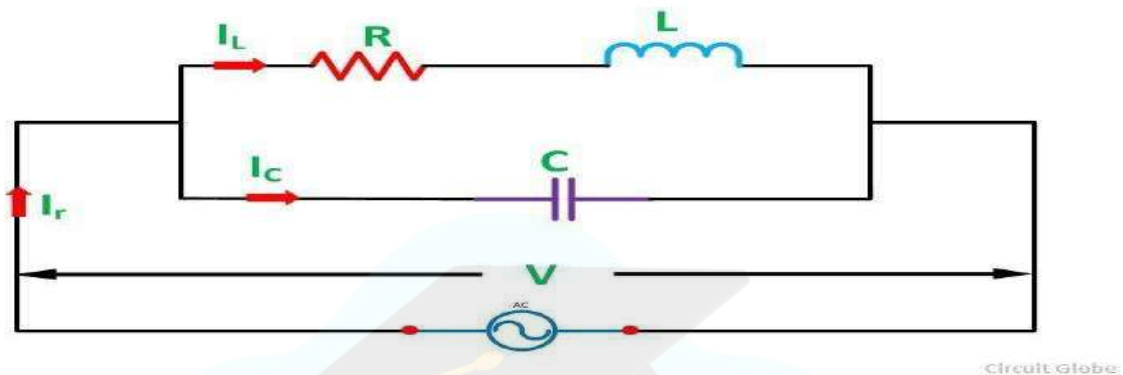

In parallel condition,

Admittance, $Y = 1/\text{Impedance}, Z.$

Susceptance, $B = 1/\text{Reactance}, X$ (Inductive Susceptance, $B_L = 1/\omega L$; Capacitive Susceptance, $B_C = \omega C$)

Conductance, $G = 1/\text{Resistance}, R$

So, $I_r = VY$ $V = \text{Supply Voltage}$ $\text{Current, } I_r = \text{Total Current}$ Admittance,

$Y = G + j(B_C - B_L)$ measured in Siemens or ohm^{-1} .

In parallel resonance , net susceptance should be equal to zero. (like in series resonance net reactance should be zero). From, the parallel circuit shown above, we have

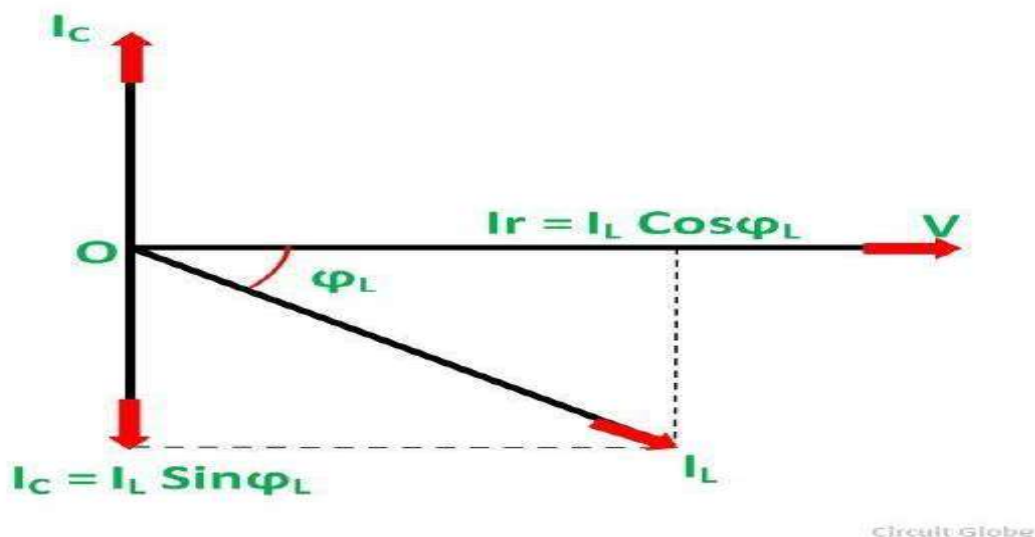

$$I_c = I_L \sin \Phi_L$$

At the Resonance condition, the circuit draws the minimum current as under this (resonance) condition the reactive component of current is suppressed.

The value of inductive reactance $X_L = 2\pi fL$ and capacitive reactance $X_C = 1/2\pi fC$ can be changed by changing the supply frequency. As the frequency increases, the value of X_L and consequently the value of Z_L increases. As a result, there is a decrease in the magnitude of current I_2 and this I_2 current lags behind the voltage V .

$$I_L = V/Z_L$$

$$\sin \Phi_L = X_L/Z_L \text{ and } I_c = V/X_C$$

$$\text{Or, } = \text{---}$$

$$X_L X_C = \text{---} \text{ or } \omega L / \omega C = \text{---} = (R^2 + \text{---})$$

$$L/C = R^2 + (2\pi f_r L)^2$$

$$2\pi f_r L = \sqrt{\frac{L}{C} - R^2}$$

$$f_r = \frac{1}{2\pi L} \sqrt{\frac{L}{C} - R^2} = \frac{1}{2\pi} \sqrt{\frac{1}{LC} - \frac{R^2}{L^2}}$$

If R is very small as compared to L , then resonant frequency will be

$$f_r = \frac{1}{2\pi\sqrt{LC}}$$

EFFECT OF PARALLEL RESONANCE

At parallel resonance line current $I_r = I_L \cos \phi$
 $\text{---} = \text{---}$ which gives circuit impedance as,

$$= \text{---}$$

Condition for parallel resonance:

- The circuit impedance is purely resistive because there is no frequency term present in it. If the value of inductance, capacitance and resistance is in Henry, Farads and Ohm then the value of circuit impedance Z_r will be in Ohms.
- The value of Z_r will be very high because the ratio L/C is very large at parallel resonance.
- The value of circuit current, $I_r = V/Z_r$ is very small because the value of Z_r is very high.
- The current flowing through the capacitor and the coil is much greater than the line current because the impedance of each branch is quite lower than that of circuit impedance Z_r .

Since the parallel resonant circuit can draw a very small current and power from the mains, therefore, it is also called as **Rejector Circuit**.

BANDWIDTH

The bandwidth (BW) of a resonant circuit is defined as the total number of cycles below and above the resonant frequency for which the current is equal to or greater than 70.7% of its

resonant value. The two frequencies in the curve that are at 0.707 of the maximum current are called band, or half-power frequencies. These frequencies are identified on the curve as f_1 and f_2 , and are often referred to as the critical frequencies, or cutoff frequencies, of a resonant circuit.

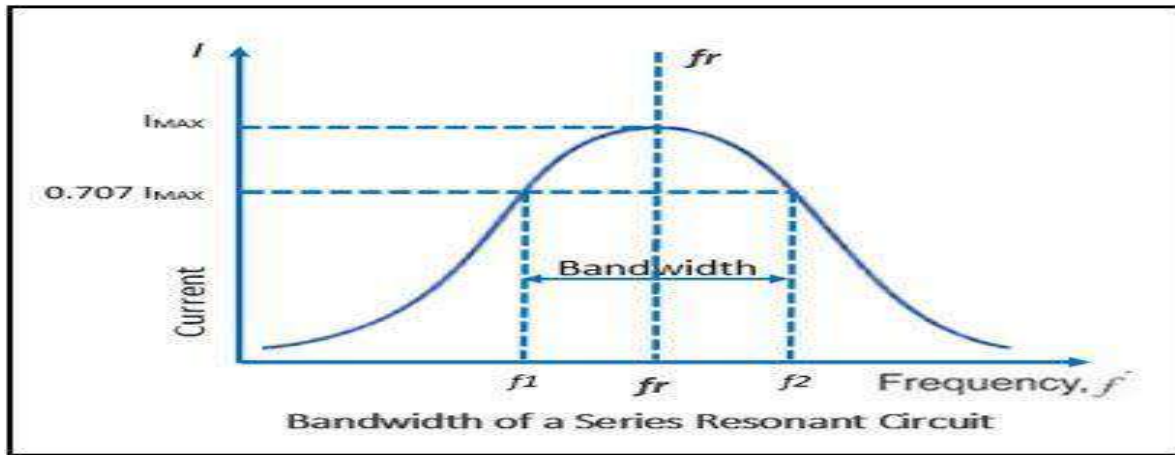

The resonant frequency can be determined from the critical frequencies by the following equation:

$$f_r = \sqrt{f_1 * f_2} \quad \text{or, } f_r = \frac{1}{2\pi\sqrt{LC}}$$

Bandwidth can be expressed mathematically as: $BW = f_2 - f_1$

Other formula used to calculate bandwidth is: $BW = f_r / Q$, where the **Q factor** is a measure of the quality of a resonance circuit represented by the letter **Q**.

Q factor is calculated using the formula: $Q = XL/R$

For example, when we are tuning in to a radio station what we're doing is adjusting the resonant frequency of a circuit to match the frequency of the carrier signal from the radio station. At the same time, we're matching the bandwidth to the music and audio that is riding on the carrier signal from the radio station.

The **quality factor** relates the maximum or peak energy stored in the circuit (the reactance) to the energy dissipated (the resistance) during each cycle of oscillation meaning that it is a ratio of resonant frequency to bandwidth and the higher the circuit Q, the smaller the bandwidth, $Q =$

$$f_r / BW = \omega_r L / R = \omega_r RC =$$

THREE PHASE BALANCED CIRCUITS

The system which has three phases, i.e., the current will pass through the three wires, and there will be one neutral wire for passing the fault current to the earth is known as the three phase system.

The sum of the line currents in the 3-phase system is equal to zero, and their phases are differentiated at an angle of 120° .

The three-phase system has several advantages:

- a) It requires fewer conductors as compared to the single phase system.

- b) It also gives the continuous supply to the load.
- c) The three-phase system has higher efficiency and minimum losses.
- d) The three phase system induces in the generator which gives the three phase voltage of equal magnitude and frequency. It provides an uninterruptible power, i.e., if one phase of the system is disturbed, then the remaining two phases of the system continue supplies the power.
- e) The magnitude of the current in one phase is equal to the sum of the current in the other two phases of the system.

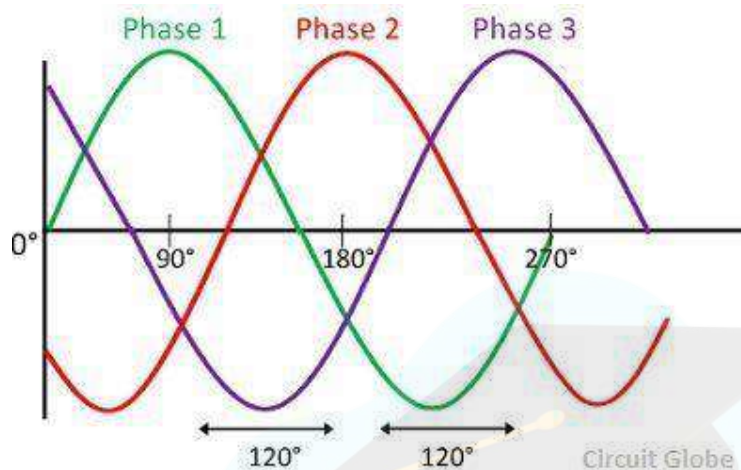

Three Phase System

Types of Connections in Three-Phase System

The three-phase systems are connected in two ways, i.e., the star connection and the delta connection.

Star Connection

The star connection requires four wires in which there are three phase conductors and one neutral conductor. Such type of connection is mainly used for long distance transmission because it has a neutral point. The neutral point passes the unbalanced current to the earth and hence make the system balance.

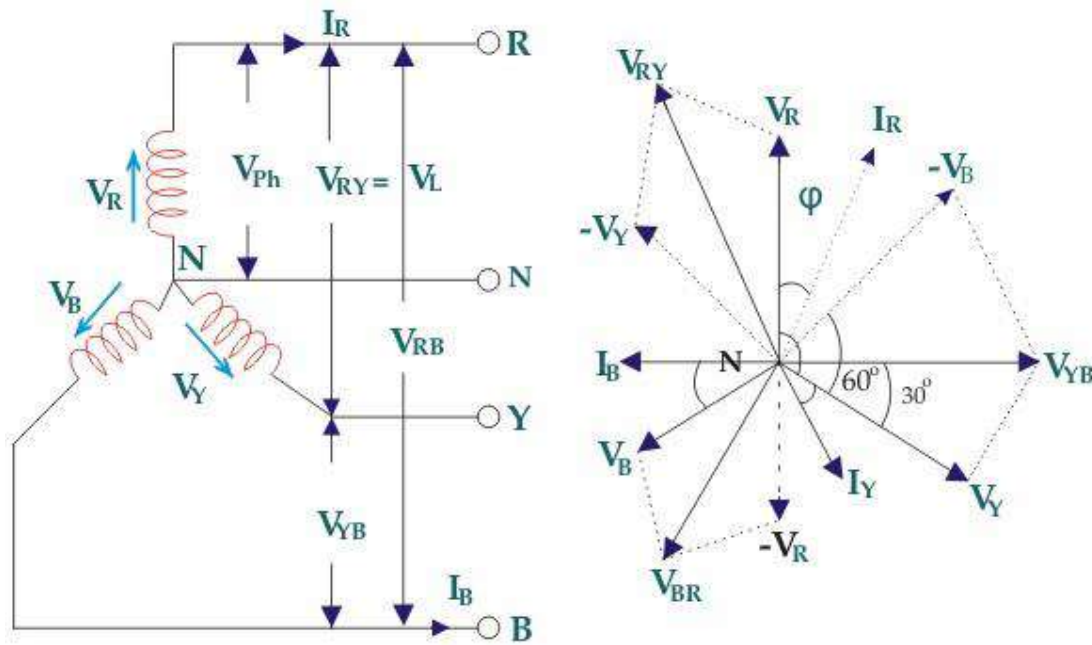

In the balanced star system, magnitude of phase voltage in each phase is V_{ph} .

$$\therefore V_R = V_Y = V_B = V_{ph}$$

line current is same as phase current. The magnitude of this current is same in all three phases and let it be I_L .

$\therefore I_R = I_Y = I_B = I_L$, Where, I_R is line current of R phase, I_Y is line current of Y phase and I_B is line current of B phase. Again, phase current, I_{ph} of each phase is same as line current I_L in star connected system.

$$\therefore I_R = I_Y = I_B = I_L = I_{ph}$$

Now, let the voltage across R and Y terminal of the star connected circuit is V_{RY} .

The voltage across Y and B terminal of the star connected circuit is V_{YB} .

From the diagram, it is found that

$$V_{RY} = V_R + (-V_Y)$$

$$\text{Similarly, } V_{YB} = V_Y + (-V_B)$$

$$\text{And, } V_{BR} = V_B + (-V_R)$$

Now, as angle between V_R and V_Y is 120° (electrical), the angle between V_R and $-V_Y$ is $180^\circ - 120^\circ = 60^\circ$ (electrical).

$$V_L = |V_{RY}| = \sqrt{V_R^2 + (-V_Y)^2 + 2 V_R (-V_Y) \cos 60^\circ}$$

$$= \sqrt{V_{ph}^2 + V_{ph}^2 - 2 V_{ph} V_{ph} \cos 60^\circ}$$

$$= \sqrt{3} V_{ph}$$

IMPORTANT POINTS:

$$V_L = \sqrt{3} V_{ph}$$

$$I_L = I_{Phase}$$

Thus, for the star-connected system line voltage = $\sqrt{3} \times$ phase voltage.

Line current = Phase current

As, the angle between voltage and current per phase is ϕ , the electric power per phase is

$$V_{ph} I_{ph} \cos \Phi = V_L I_L \cos \Phi / \sqrt{3}$$

So the total power of three phase system is

$$3 * V_L I_L \cos \Phi / \sqrt{3} = \sqrt{3} V_L I_L \cos \Phi$$

Delta Connection

The delta connection has three wires, and there is a no neutral point. The delta connection is shown in the figure below. The line voltage of the delta connection is equal to the phase voltage.

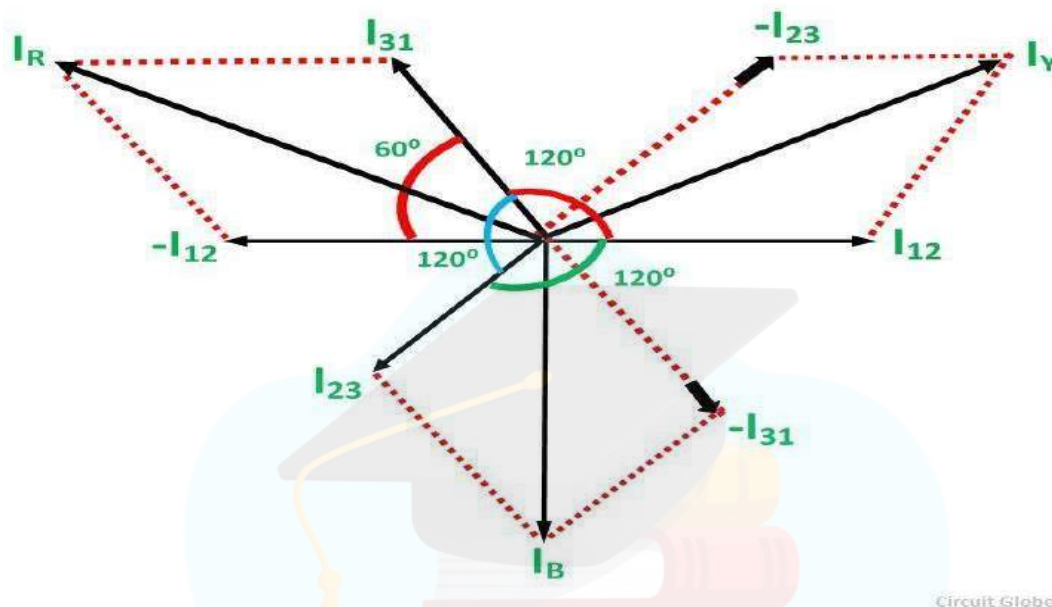

As in the balanced system the three-phase current I_{12} , I_{23} and I_{31} are equal in magnitude but are displaced from one another by 120° electrical.

$$I_{12}, I_{23} \text{ and } I_{31} = I_{ph}$$

If we look at figure A, it is seen that the current is divided at every junction 1, 2 and 3.

Applying Kirchhoff's Law at junction 1,

The Incoming currents are equal to outgoing currents. $I_{31} = I_R + I_{12}$

The vector I_{12} is reversed and is added in the vector I_{31} to get the vector sum of I_{31} and $-I_{12}$ as shown above in the phasor diagram. Therefore,

$$I_R = \sqrt{I_{31}^2 + I_{12}^2 + 2 I_{31} I_{12} \cos 60}$$

$$I_L = \sqrt{I_{31}^2 + I_{12}^2 + 2 I_{31} I_{12} \cos 60}$$

$$= \sqrt{3} I_{ph}$$

IMPORTANT POINTS:

$$I_{\text{Line}} = \sqrt{3}I_{\text{ph}}$$

$$V_{\text{line}} = V_{\text{phase}}$$

Module - 3 : Transformers

Contents: Magnetic materials, BH characteristics, ideal and practical transformer, equivalent circuit, losses in transformers, regulation and efficiency. Auto-transformer and three-phase transformer connections.

Classification of Magnetic Materials:

All materials can be classified in terms of their magnetic behavior falling into one of five categories depending on their bulk magnetic susceptibility. The two most common types of magnetism are diamagnetism and paramagnetism, which account for the magnetic properties of most of the periodic table of elements at room temperature.

Diamagnetism: In a diamagnetic material the atoms have no net magnetic moment when there is no applied field. Under the influence of an applied field (H) the spinning electrons precess and this motion, which is a type of electric current, produces a magnetisation (M) in the opposite direction to that of the applied field. All materials have a diamagnetic effect, however, it is often the case that the diamagnetic effect is masked by the larger paramagnetic or ferromagnetic term. The value of susceptibility is independent of temperature.

Paramagnetism: There are several theories of paramagnetism, which are valid for specific types of material. The Langevin model, which is true for materials with non-interacting localised electrons, states that each atom has a magnetic moment which is randomly oriented as a result of thermal agitation. The application of a magnetic field creates a slight alignment of these moments and hence a low magnetisation in the same direction as the applied field. As the temperature increases, then the thermal agitation will increase and it will become harder to align the atomic magnetic moments and hence the susceptibility will decrease. This behaviour is known as the Curie law.

Ferromagnetism: Ferromagnetism is only possible when atoms are arranged in a lattice and the atomic magnetic moments can interact to align parallel to each other. This effect is explained in classical theory by the presence of a molecular field within the ferromagnetic material, which was first postulated by Weiss in 1907. This field is sufficient to magnetise the material to saturation. In quantum mechanics, the Heisenberg model of ferromagnetism describes the parallel alignment of magnetic moments in terms of an exchange interaction between neighbouring moments. Weiss postulated the presence of magnetic domains within the material, which are regions where the atomic magnetic moments are aligned. The movement of these domains determines how the material responds to a magnetic field and as a consequence the susceptibility is a function of applied magnetic field. Therefore, ferromagnetic materials are usually compared in terms of saturation magnetisation (magnetisation when all domains are aligned) rather than susceptibility. In the periodic table of elements only Fe, Co and Ni are ferromagnetic at and above room temperature. As ferromagnetic materials are heated then the thermal agitation of the atoms means that the degree of alignment of the atomic magnetic moments decreases and hence the saturation magnetisation also decreases.

Anti-ferromagnetism: In the periodic table the only element exhibiting antiferromagnetism at room temperature is chromium. Antiferromagnetic materials are very similar to ferromagnetic materials but the exchange interaction between neighbouring atoms leads to the anti-parallel

alignment of the atomic magnetic moments. Therefore, the magnetic field cancels out and the material appears to behave in the same way as a paramagnetic material. Like ferromagnetic materials these materials become paramagnetic above a transition temperature, known as the Néel temperature, T_N . (Cr: $T_N=37^\circ\text{C}$).

Ferrimagnetism: Ferrimagnetism is only observed in compounds, which have more complex crystal structures than pure elements. Within these materials the exchange interactions lead to parallel alignment of atoms in some of the crystal sites and anti-parallel alignment of others. The material breaks down into magnetic domains, just like a ferromagnetic material and the magnetic behaviour is also very similar, although ferrimagnetic materials usually have lower saturation magnetisations. For example in Barium ferrite ($\text{Ba}_0.6\text{Fe}_2\text{O}_3$).

Type	Example	Atomic/Magnetic Behaviour		
Diamagnetism	Inert gases; many metals eg Au, Cu, Hg; non-metallic elements e.g. B, Si, P, S; many ions e.g. Na^+ , Cl^- & their salts; diatomic molecules e.g. H_2 , N_2 ; H_2O ; most organic compounds	Atoms have no magnetic moment. Susceptibility is small & negative, -10^{-6} to -10^{-5}		
Paramagnetism	Some metals, e.g. Al; some diatomic gases, e.g. O_2 , NO; ions of transition metals and rare earth metals, and their salts; rare earth oxides.	Atoms have randomly oriented magnetic moments. Susceptibility is small & positive, $+10^{-5}$ to $+10^{-3}$		
Ferromagnetism	Transition metals Fe, H, Co, Ni; rare earths with $64 \leq Z \leq 69$; alloys of ferromagnetic elements; some alloys of Mn, e.g. MnBi, Cu_2MnAl .	Atoms have parallel aligned magnetic moments. Susceptibility is large (below T_c)		
Antiferromagnetism	Transition metals Mn, Cr & many of their compound, e.g. MnO, CoO, NiO, Cr_2O_3 , MnS, MnSe, CuC_2O_4 .	Atoms have anti-parallel aligned magnetic moments. Susceptibility is small & positive, $+10^{-5}$ to $+10^{-3}$		
Ferrimagnetism	Fe_3O_4 (magnetite); $\gamma\text{-Fe}_2\text{O}_3$ (maghemite); mixed oxides of iron and other elements such as Sr ferrite.	Atoms have mixed parallel and anti-parallel aligned magnetic moments. Susceptibility is large (below T_c)		

Table 2: A summary of the different types of magnetic behaviour.

Magnetic hysteresis:

1. Once magnetic saturation has been achieved, a decrease in the applied field back to zero results in a macroscopically permanent or residual magnetization, known as remanance, M_r . The corresponding induction, B_r , is called retentivity or remanent induction of the magnetic material. This effect of retardation by material is called hysteresis.

2. The magnetic field strength needed to bring the induced magnetization to zero is termed as coercivity, H_c . This must be applied anti-parallel to the original field.
3. A further increase in the field in the opposite direction results in a maximum induction in the opposite direction. The field can once again be reversed, and the field-magnetization loop can be closed, this loop is known as hysteresis loop or B-H plot or M- H plot.

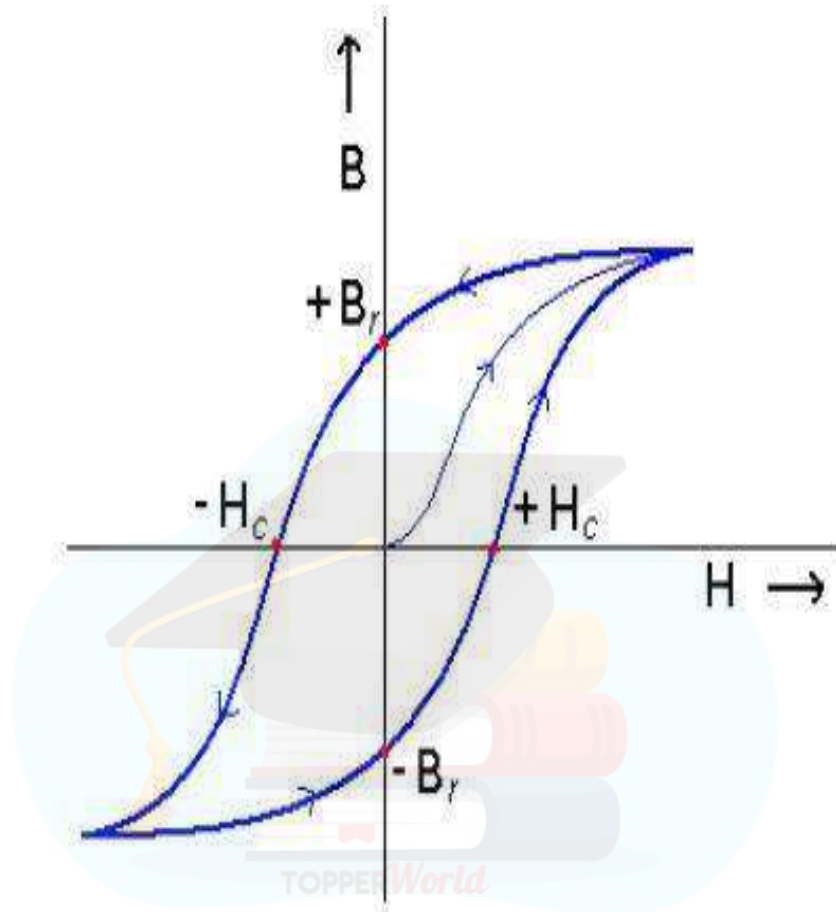

Semi-hard magnets:

- The area within the hysteresis loop represents the energy loss per unit volume of material for one cycle.
- The coercivity of the material is a micro-structure sensitive property. This dependence is known as magnetic shape anisotropy.
- The coercivity of recording materials needs to be smaller than that for others since data written onto a data storage medium should be erasable. On the other hand, the coercivity values should be higher since the data need to be retained. Thus such materials are called magnetically semi-hard.
- Ex.: Hard ferrites based on Ba, CrO_2 , $\gamma\text{-Fe}_2\text{O}_3$; alloys based on Co-Pt-Ta-Cr, Fe-Pt and Fe-Pd, etc.

Soft magnets:

1. Soft magnets are characterized by low coercive forces and high magnetic permeabilities; and are easily magnetized and de-magnetized.
2. They generally exhibit small hysteresis losses.

3. Application of soft magnets include: cores for electro-magnets, electric motors, transformers, generators, and other electrical equipment.

4.Ex.: ingot iron, low-carbon steel, Silicon iron, superalloy (80% Ni-5% Mo-Fe), 45 Permalloy (55%Fe-45%Ni), 2-79 Permalloy (79% Ni-4% Mo-Fe), MnZn ferrite / Ferroxcube A (48% MnFe₂O₄-52%ZnFe₂O₄), NiZn ferrite / Ferroxcube B (36% NiFe₂O₄-64% ZnFe₂O₄), etc.

Hard magnets:

1. Hard magnets are characterized by high remanent inductions and high coercivities. •These are also called permanent magnets or hard magnets.
2. These are found useful in many applications including fractional horse-power motors, automobiles, audio- and video- recorders, earphones, computer peripherals, and clocks.
3. They generally exhibit large hysteresis losses.
4. Ex.: Co-steel, Tungsten steel, SmCo₅, Nd₂Fe₁₄B, ferrite Bao.6Fe₂O₃, Cunife (60% Cu 20% Ni20% Fe), Alnico (alloy of Al, Ni, Co and Fe), etc

TRANSFORMER:

Working principle of transformer:

A Transformer is a static electrical device that transfers electrical energy between two or more circuits through electromagnetic induction. A varying current in one coil of the transformer produces a varying magnetic field, which in turn induces a varying electromotive force (e.m.f) or "voltage" in a second coil. Power can be transferred between the two coils through the magnetic field, without a metallic connection between the two circuits. Faraday's law of induction discovered in 1831 described this effect. Transformers are used to increase or decrease the alternating voltages in electric power applications.

Since the invention of the first constant-potential transformer in 1885, transformers have become essential for the transmission, distribution, and utilization of alternating current electrical energy. A wide range of transformer design is encountered in electronic and electric power applications.

E.M.F Equation of Transformer:

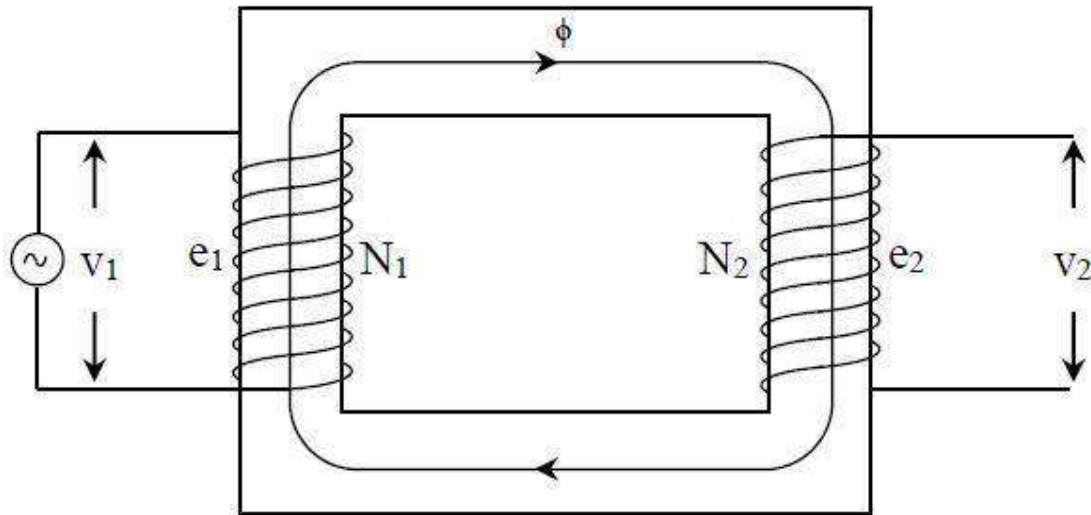

Core type single phase transformer

The primary winding draws a current when it is connected to an alternating voltage source this sinusoidal current produces a sinusoidal flux Φ that can be expressed as:

$$\Phi = \Phi_m \sin \omega t \quad (1)$$

Instantaneous emf induced in the primary windings is:

$$e_1 = -N_1 \frac{d\Phi}{dt} \quad (2)$$

Similarly, instantaneous emf induced in the secondary windings is:

$$e_2 = -N_2 \frac{d\Phi}{dt} \quad (3)$$

Put the value of Φ in equation 1.

$$e_1 = -N_1 \frac{d(\Phi_m \sin \omega t)}{dt} \quad (4)$$

$$= -N_1 \omega \Phi_m \cos \omega t \quad (5) = -$$

$$\Phi_m \cos \omega t \quad (6)$$

$$= N_1 \omega \Phi_m \sin(\omega t - \frac{\pi}{2}) \quad (7)$$

$$= N_1 \omega \Phi_m \sin(\omega t - \frac{\pi}{2}) \quad (7)$$

$$= N_1 \omega \Phi_m \sin \omega t$$

So its RMS value

$$\begin{aligned} E_{m1} &= \frac{N_1 \omega \Phi_m}{\sqrt{2}} = \frac{N_1 \omega \Phi_m}{\sqrt{2}} = \frac{N_1 \Phi_m 2\pi f}{\sqrt{2}} = 4.44 f \Phi_m \\ &= 4.44 \Phi_m \end{aligned} \quad (8)$$

Similarly RMS values of secondary induced emf

$$= 4.44 \phi \quad (9)$$

For ideal transformer :

Induced emf in primary (E1) = Applied Voltage (V1)

Induced emf in secondary (E2) = Terminal Voltage (V2)

From equations (8) & (9)

$$\frac{V_1}{N_1} = \frac{V_2}{N_2} = 4.44 \phi$$

Hence ϕ = constant

Voltage and current transformation ratio:

Again from equations (8) & (9)

$$\frac{V_1}{N_1} = \frac{V_2}{N_2} = \frac{I_1 N_1}{I_2 N_2}$$

K= Voltage (Current) transformation ratio

For ideal transformer

Input VA = Output VA

Hence

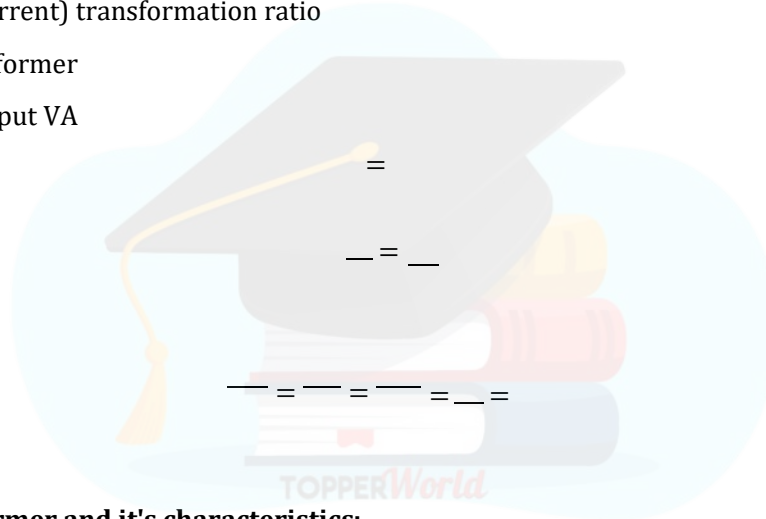

Ideal transformer and it's characteristics:

An **ideal transformer** is an imaginary transformer which has

- no copper losses (no winding resistance)
- no iron loss in core
- no leakage flux

In other words, an ideal transformer gives output power exactly equal to the input power. The **efficiency of an idea transformer** is 100%. Actually, it is impossible to have such a [transformer](#) in practice, but **ideal transformer model** makes problems easier.

Characteristics of ideal transformer:

- **Zero winding resistance:** It is assumed that, resistance of primary as well as secondary winding of an ideal transformer is zero. That is, both the coils are purely inductive in nature.
- **Infinite permeability of the core:** Higher the permeability, lesser the mmf required for flux establishment. That means, if permeability is high, less magnetizing current is required to magnetize the transformer core.

X_1 and X_2 = **leakage reactance** of primary and secondary winding resp.

Z_1 and Z_2 = Primary impedance and secondary impedance resp.

$Z_1 = R_1 + jX_1$...and $Z_2 = R_2 + jX_2$.

The impedance in each winding lead to some voltage drop in each winding. Considering this voltage drop the **voltage equation of transformer** can be given as -

$V_1 = E_1 + I_1(R_1 + jX_1)$ -----primary side

$V_2 = E_2 - I_2(R_2 + jX_2)$ -----secondary side

where, V_1 = supply voltage of primary winding

V_2 = terminal voltage of secondary winding

E_1 and E_2 = induced emf in primary and secondary winding respectively. (EMF equation of a transformer.)

Equivalent circuit of transformer:

In a practical [transformer](#) -

(a) Some [leakage flux](#) is present at both primary and secondary sides. This leakage gives rise to leakage reactances at both sides, which are denoted as X_1 and X_2 respectively. (b) Both the primary and secondary winding possesses resistance, denoted as R_1 and R_2 respectively.

These resistances causes voltage drop as, I_1R_1 and I_2R_2 and also [copper loss](#) $I_1^2R_1$ and $I_2^2R_2$.

(c) Permeability of the core can not be infinite, hence some magnetizing current is needed.

Mutual flux also causes [core loss](#) in iron parts of the transformer.

We need to consider all the above things to derive **equivalent circuit of a transformer**.

[Resistances and reactances of transformer](#), which are described above, can be imagined separately from the windings (as shown in the figure below). Hence, the function of windings, thereafter, will only be the transforming the voltage.

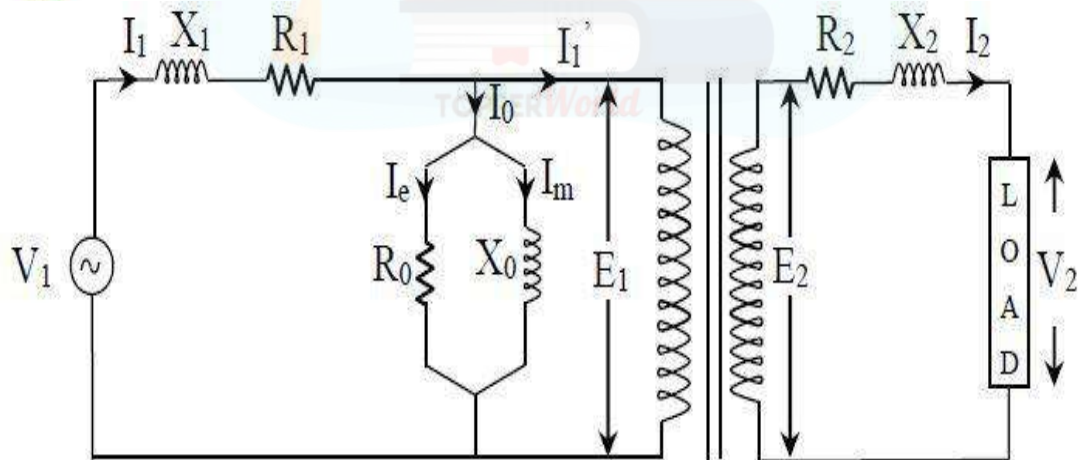

The no load current I_0 is divided into, pure inductance X_0 (taking magnetizing components I_μ) and non induction resistance R_0 (taking working component I_w) which are connected into parallel across the primary. The value of E_1 can be obtained by subtracting I_1Z_1 from V_1 . The value of R_0 and X_0 can be calculated as, $R_0 = E_1 / I_w$ and $X_0 = E_1 / I_\mu$.

But, using this equivalent circuit does not simplifies the calculations. To make calculations simpler, it is preferable to transfer current, voltage and impedance either to primary side or to

the secondary side. In that case, we would have to work with only one winding which is more convenient.

From the voltage transformation ratio, it is clear that,
 $E_1 / E_2 = N_1 / N_2 = K$
Now, let's refer the parameters of secondary side to primary.
 Z_2 can be referred to primary as Z_2' where, $Z_2' = (N_1/N_2)^2 Z_2$
 $= K^2 Z_2$where $K = N_1/N_2$.
that is, $R_2' + jX_2' = K^2(R_2 + jX_2)$ equating
real and imaginary parts,
 $R_2' = K^2 R_2$ and $X_2' = K^2 X_2$.
And $V_2' = K V_2$

Equivalent circuit of transformer with secondary parameters referred to the primary:

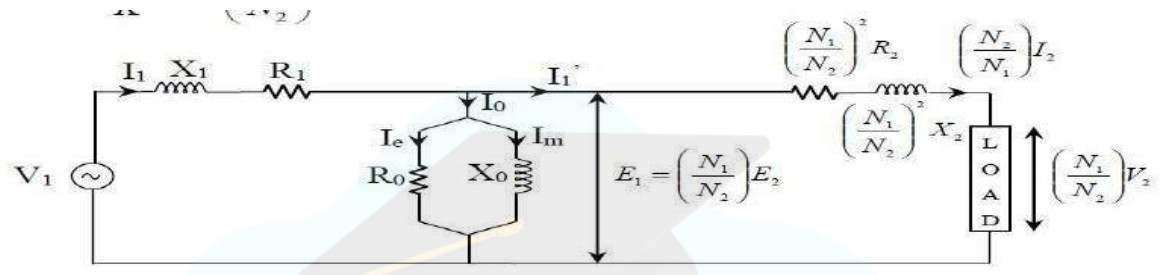

Fig:

XX

Approximate equivalent circuit of transformer:

If only voltage regulation is to be calculated, then even the whole excitation branch (parallel combination of R0 and X0) can be neglected. Then the equivalent circuit becomes as shown in the figure below.

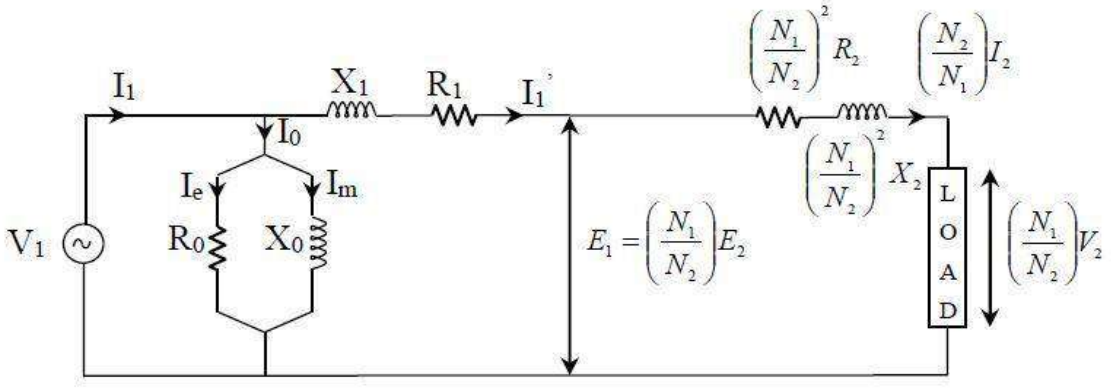

Fig: Approximately Equivalent Circuit Referred to primary side after shifting parallel branch

Efficiency of Transformer

Just like any other electrical machine, **efficiency of a transformer** can be defined as the output power divided by the input power. That is $\text{efficiency} = \text{output} / \text{input}$.

Transformers are the most highly efficient electrical devices. Most of the transformers have full load efficiency between 95% to 98.5%. As a transformer being highly efficient, output and input are having nearly same value, and hence it is impractical to measure the efficiency of transformer by using $\text{output} / \text{input}$. A better method to find efficiency of a transformer is using, $\text{efficiency} = (\text{input} - \text{losses}) / \text{input} = 1 - (\text{losses} / \text{input})$.

Condition for maximum efficiency

Let,

$$\text{Copper loss} = I_1^2 R_1$$

$$\text{Iron loss} = W_i$$



differentiating above equation with respect to I_1

$$\frac{d\eta}{dI_1} = 0 = \frac{R_1}{V_1 \cos\Phi_1} + \frac{W_i}{V_1 I_1^2 \cos\Phi_1}$$

η will be maximum at $\frac{d\eta}{dI_1} = 0$

Hence efficiency η will be maximum at

$$\frac{R_1}{V_1 \cos\Phi_1} = \frac{W_i}{V_1 I_1^2 \cos\Phi_1}$$

$$\frac{I_1^2 R_1}{V_1 I_1^2 \cos\Phi_1} = \frac{W_i}{V_1 I_1^2 \cos\Phi_1}$$

$$I_1^2 R_1 = W_i$$

Hence, **efficiency of a transformer** will be maximum when copper loss and iron losses are equal. That is Copper loss = Iron loss.

Voltage Regulation of Transformer:

Voltage regulation is a measure of change in the voltage magnitude between the sending and receiving end of a component. It is commonly used in power engineering to describe the percentage voltage difference between no load and full load voltages distribution lines, transmission lines, and transformers.

Explanation of Voltage Regulation of Transformer: An electrical power transformer is open circuited, meaning that the load is not connected to the secondary terminals. In this situation, the secondary terminal voltage of the transformer will be its secondary induced emf E_2 . Whenever a full load is connected to the secondary terminals of the transformer, rated current I_2 flows through the secondary circuit and voltage drop comes into picture. At this situation, primary winding will also draw equivalent full load current from source. The voltage drop in the secondary is I_2Z_2 where Z_2 is the secondary impedance of transformer. Now if at this loading condition, any one measures the voltage between secondary terminals, he or she will get voltage V_2 across load terminals which is obviously less than no load secondary voltage E_2 and this is because of I_2Z_2 voltage drop in the transformer.

Expression of Voltage Regulation of Transformer

The equation for the **voltage regulation of transformer**, represented in percentage, is

$$\text{Voltage regulation}(\%) = \frac{E_2 - V_2}{V_2} \times 100\%$$

Voltage Regulation of Transformer for Lagging Power Factor

$$\begin{aligned} \text{Voltage regulation} (\%) &= \frac{E_2 - V_2}{V_2} \times 100(\%) \\ &= \frac{I_2R_2 \cos \theta_2 + I_2X_2 \sin \theta_2}{V_2} \times 100(\%) \end{aligned}$$

Voltage Regulation of Transformer for Leading Power Factor

$$\begin{aligned} \text{Voltage regulation} (\%) &= \frac{E_2 - V_2}{V_2} \times 100(\%) \\ &= \frac{I_2R_2 \cos \theta_2 - I_2X_2 \sin \theta_2}{V_2} \times 100(\%) \end{aligned}$$

Zero Voltage Regulation of A Transformer

'Zero voltage regulation' indicates that there is no difference between its 'no-load voltage' and its 'full-load voltage'. This means that in the voltage regulation equation above, voltage regulation is equal to zero. This is not practical – and is only theoretically possible in the case for an ideal transformer.

Auto transformer:

An **auto transformer** is an [electrical transformer](#) having only one winding. The winding has at least three terminals which is explained in the construction details below.

Some of the **advantages of auto-transformer** are that,

- they are smaller in size,
- cheap in cost,
- low [leakage reactance](#),
- increased kVA rating, □ low exciting current etc.

An example of **application of auto transformer** is, using an US electrical equipment rated for 115 V supply (they use 115 V as standard) with higher Indian voltages. Another example could be in starting method of [three phase induction motors](#).

Construction of auto transformer

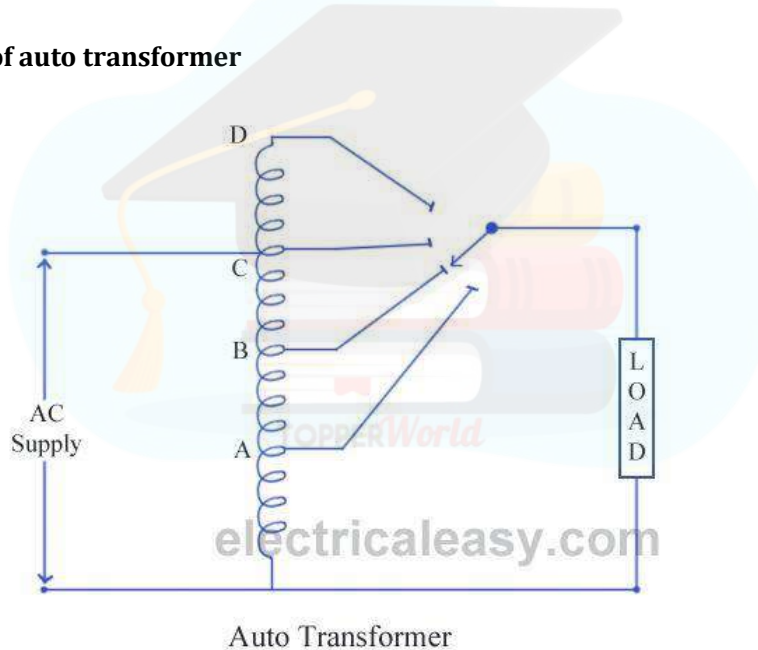

An auto transformer consists of a single copper wire, which is common in both primary as well as secondary circuit. The copper wire is wound a laminated silicon steel core, with at least three tappings taken out. Secondary and primary circuit share the same neutral point of the winding. The construction is well explained in the diagram. Variable turns ratio at secondary can be obtained by the tappings of the winding (as shown in the figure), or by providing a smooth sliding brush over the winding. Primary terminals are fixed. Thus, in an auto transformer, you may say, primary and secondary windings are connected magnetically as well as electrically.

Working of auto transformer:

As I have described just above, an auto transformer has only one winding which is shared by both primary and secondary circuit, where number of turns shared by secondary are variable. EMF induced in the winding is proportional to the number of turns. Therefore, the secondary voltage can be varied by just varying secondary number of turns.

As winding is common in both circuits, most of the energy is transferred by means of electrical conduction and a small part is transferred through induction.

The considerable **disadvantages of an auto transformer** are,

- any undesirable condition at primary will affect the equipment at secondary (as windings are not electrically isolated),
- due to low impedance of auto transformer, secondary short circuit currents are very high,
- harmonics generated in the connected equipment will be passed to the supply.

Three Phase Transformer Connections:

[Three phase transformer](#) connections In three phase system, the three phases can be connected in either star or delta configuration. In case you are not familiar with those configurations, study the following image which explains star and delta configuration. In any of these configurations, there will be a phase difference of 120° between any two phases.

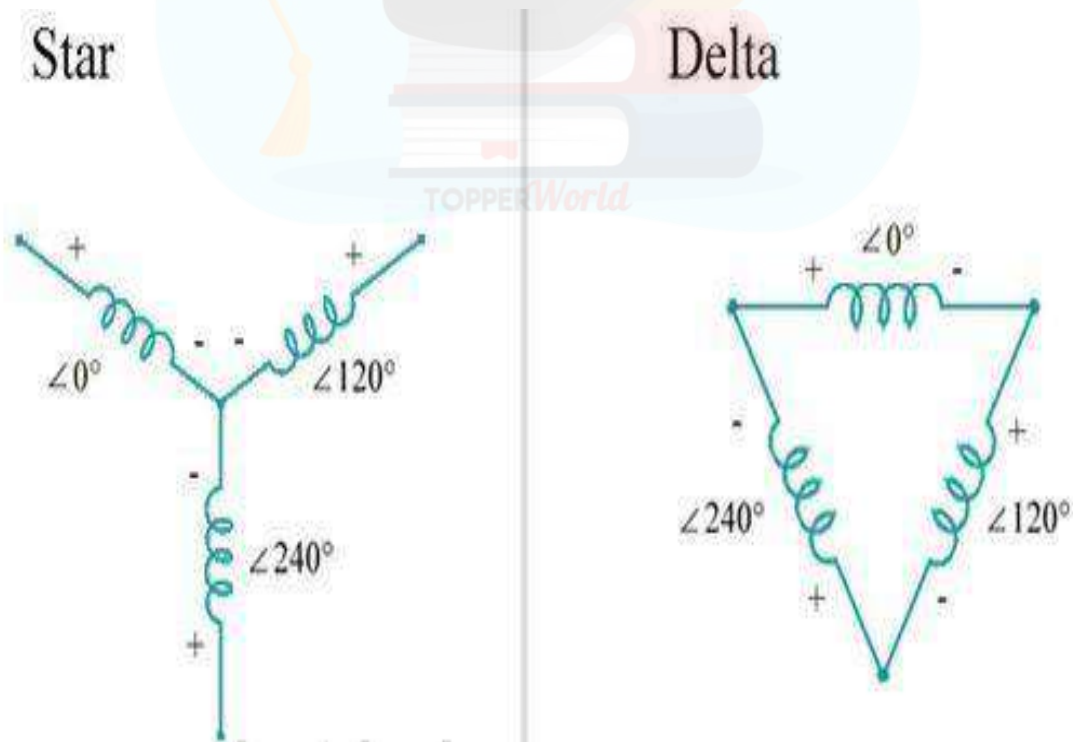

Three phase transformer connections

Windings of a three phase transformer can be connected in various configurations as (i) starstar, (ii) delta-delta, (iii) star-delta, (iv) delta-star, These configurations are explained below.

Star-star (Y-Y)

- Star-star connection is generally used for small, high-voltage transformers. Because of star connection, number of required turns/phase is reduced (as phase voltage in star connection is $1/\sqrt{3}$ times of line voltage only). Thus, the amount of insulation required is also reduced.
- The ratio of line voltages on the primary side and the secondary side is equal to the transformation ratio of the transformers.
- Line voltages on both sides are in phase with each other.
- This connection can be used only if the connected load is balanced.

Delta-delta (Δ - Δ)

- This connection is generally used for large, low-voltage transformers. Number of required phase/turns is relatively greater than that for star-star connection.
- The ratio of line voltages on the primary and the secondary side is equal to the transformation ratio of the transformers.
- This connection can be used even for unbalanced loading.
- Another advantage of this type of connection is that even if one transformer is disabled, system can continue to operate in open delta connection but with reduced available capacity.

Star-delta OR wye-delta (Y- Δ)

- The primary winding is star star (Y) connected with grounded neutral and the secondary winding is delta connected.
- This connection is mainly used in step down transformer at the substation end of the transmission line.
- The ratio of secondary to primary line voltage is $1/\sqrt{3}$ times the transformation ratio. □
There is 30° shift between the primary and secondary line voltages.

Delta-star OR delta-wye (Δ -Y)

- The primary winding is connected in delta and the secondary winding is connected in star with neutral grounded. Thus it can be used to provide 3-phase 4-wire service.
- This type of connection is mainly used in step-up transformer at the beginning of transmission line.
- The ratio of secondary to primary line voltage is $\sqrt{3}$ times the transformation ratio. □
There is 30° shift between the primary and secondary line voltages.

Above transformer connection configurations are shown in the following figure.

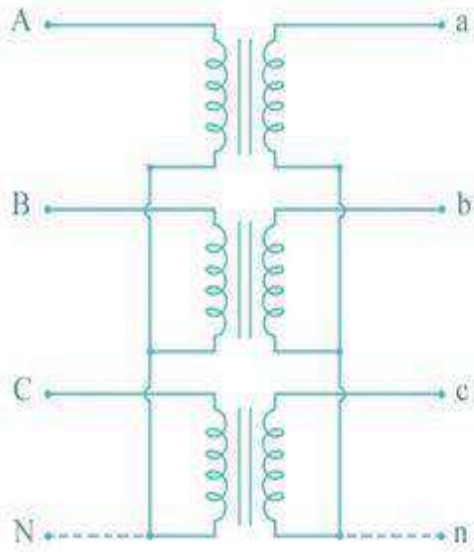

Y - Y

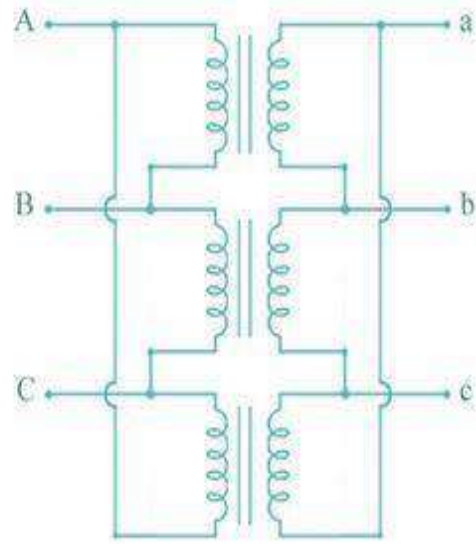

Δ - Δ

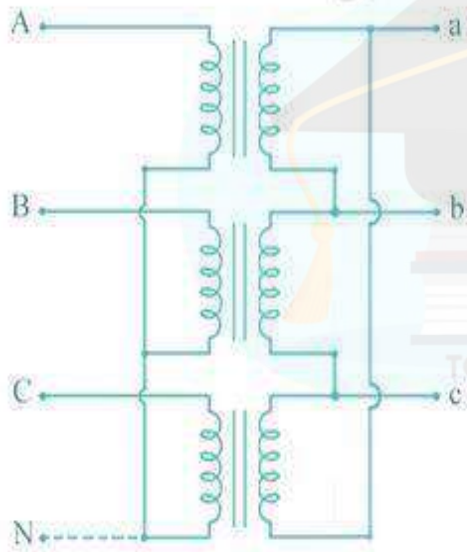

Y - Δ

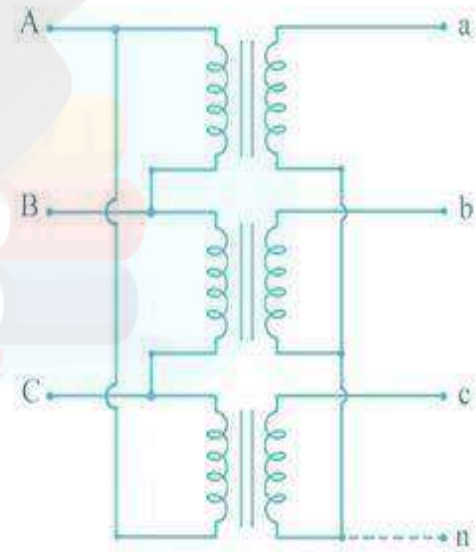

Δ - Y

MODULE 4: Electrical Machines

Contents: DC machines: Principle & Construction, Types, EMF equation of generator and torque equation of motor, applications of DC motors (simple numerical problems) Three Phase Induction Motor: Principle & Construction, Types, Slip-torque characteristics, Applications (Numerical problems related to slip only) Single Phase Induction motor: Principle of operation and introduction to methods of starting, applications. Three Phase Synchronous Machines: Principle of operation of alternator and synchronous motor and their applications.

Construction of DC Machine:-

DC Generator:- Electrical machine which converts mechanical energy into electrical energy.

DC Motor: - Electrical machine which converts electrical energy into mechanical energy.

A DC machine consists of two basic parts; stator and rotor. Basic constructional parts of a DC machine are described below.

Stator is the stationary part of the machine and rotor is the rotator part of the machine

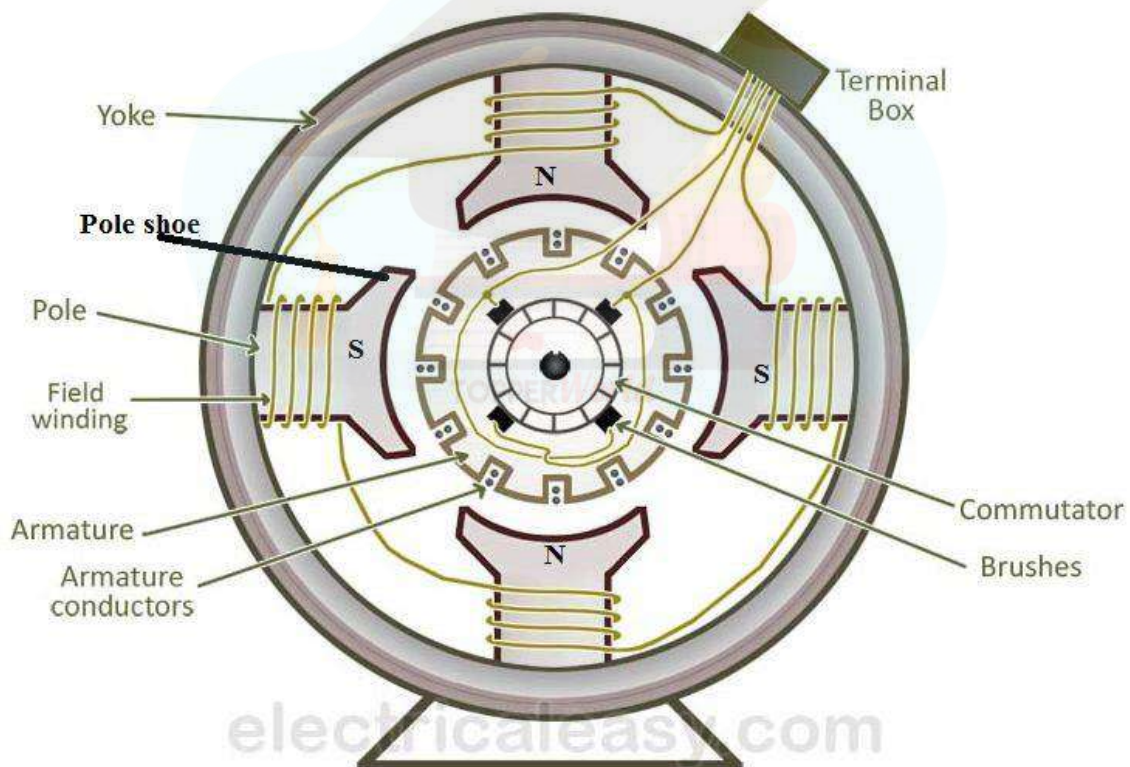

Yoke or Magnetic frame: The outer frame of a dc machine is called as yoke. It is made up of cast iron or steel. Yoke serve two purposes, firstly it provides mechanical protection to the outer parts of the machine secondly it provides low reluctance path for the magnetic flux.

Poles and pole shoes: The pole and pole shoe are fixed on the yoke by bolts.. They carry field winding and pole shoes are fastened to them. Pole shoes serve two purposes; (i) they support field coils and (ii) spread out the flux in air gap uniformly.

Field winding: They are usually made of copper. Field coils are former wound and placed on each pole and are connected in series. They are wound in such a way that, when energized, they form alternate North and South poles.

Armature core: Armature core is the rotor of a dc machine. It is cylindrical in shape with slots to carry armature winding. The armature is built up of thin laminated circular steel disks for reducing eddy current losses. It may be provided with air ducts for the axial air flow for cooling purposes. Armature is keyed to the shaft.

Armature winding: It is usually a former wound copper coil which rests in armature slots. The armature conductors are insulated from each other and also from the armature core. Armature winding can be wound by one of the two methods; lap winding or wave winding. Double layer lap or wave windings are generally used.

Commutator : Physical connection to the armature winding is made through a commutatorbrush arrangement. The function of a commutator, in a dc machine

1. It provides link between rotating armature conductor and stationary electrical circuit by brushes.
2. It converts alternating current produced in armature conductors to a unidirectional current in the external load circuit.

A commutator consists of a set of copper segments which are insulated from each other. The number of segments is equal to the number of armature coils. Each segment is connected to an armature coil and the commutator is keyed to the shaft.

Brushes:- Brushes are usually made from carbon or graphite. They rest on commutator segments and slide on the segments when the commutator rotates keeping the physical contact to collect or supply the current.

EMF EQUATION OF D.C. MACHINE :-

Let

ϕ = flux per pole

P = Total no. of poles

Z = Total number of active conductors on the armature

A = No. of parallel paths in the armature winding

For Lap Winding:-- A = P, Wave Winding: -- A = 2

N = speed of rotation of the armature in rpm(revolution per minute) ω_m

= speed in radians per second

When the rotor rotates in the field a voltage is developed in the armature.

The flux cut by one conductor in one rotation = $P\phi$

Time taken to complete one revolution =

According to faraday's law of electromagnetic induction, emf induced is given by: $E = \frac{d\phi}{dt}$

Hence emf induced by one conductor is given by: $E = \frac{P\phi N}{60}$

Total Z no. of conductor connected in series with A parallel path =

Total emf induced is given by :- $E = \phi$

$$E \propto \phi N$$

$$E = k\phi N$$

Here k=___

Torque equation of dc machine:- Electrical

input= Mechanical output

$$E.I_a = \omega.T$$

Here E=Input voltage, I_a =Armature current,

ω =Angular velocity($\omega=2\pi n/60$), T=Torque

$$T = E.I_a / \omega \text{ -----(1)}$$

Because $E = P\phi Z n / 60.a$ and $\omega = 2\pi n / 60$

Put the value of E and ω in equation (1), We get

$$T = \frac{\frac{P\phi Z n}{60.a} . I_a}{\frac{2\pi n}{60.a}} = \frac{P\phi Z I_a}{2\pi a}$$

Here K=___

$$T \propto \phi I_a$$

Classification of DC generator:-

DC generators are classified based on their method of excitation. So on this basis there are two types of DC generators:- 1. Separately excited DC generator

2. Self-excited DC generator

Self-excited DC generator can again be classified as

1) DC Series generator 2) DC Shunt generator 3) DC Compound generator.

1) Separately excited DC generator: - Dc generator has a field magnet winding which is excited using a separate voltage source (like battery). You can see the representation in the below image. The output voltage depends on the speed of rotation of armature and field current. The higher the speed of rotation and current - the higher the output e.m.f.

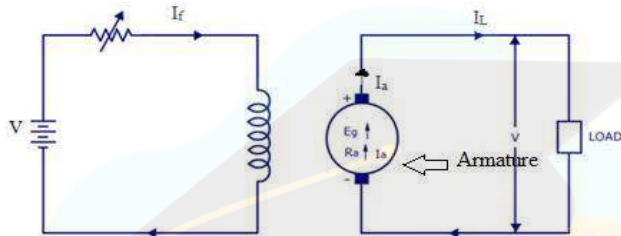

2. Self Excited DC Generator

These are generators in which the field winding is excited by the output of the generator itself. As described before - there are three types of self-excited dc generators - they are

1) Series 2) Shunt 3) Compound.

1. Series DC Generator:-A series DC generator is shown below in fig (a) - in which the armature winding is connected in series with the field winding so that the field current flows through the load as well as the field winding. The field winding is a low resistance, thick wire of few turns. Series generators are also rarely used.

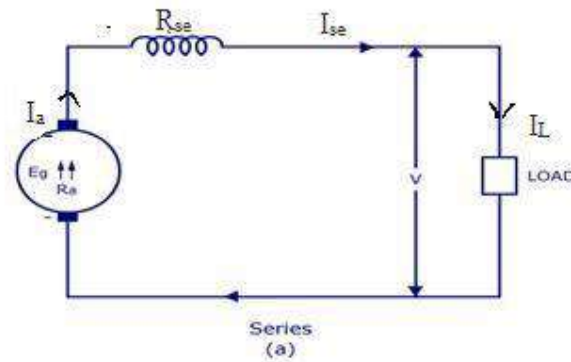

Here $I_a = I_{se} = I_L$

The output voltage is given by:- $V = E_g - I_a \cdot R_a - I_a \cdot R_{se}$

$$V = E_g - I_a \cdot (R_a + R_{se})$$

2. **Shunt DC Generator**:- A shunt DC generator is shown in figure (b), in which the field winding is wired parallel to armature winding so that the voltage across both are same. The field winding has high resistance and more number of turns so that only a part of armature current passes through field winding and the rest passes through load. It is also called as constant flux machine.

Here $I_a = I_{sh} + I_L$

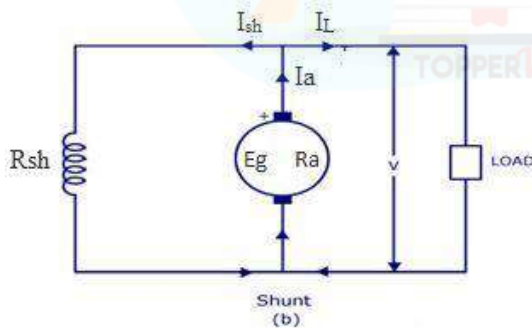

The output voltage is given by:- $V = E_g - I_a \cdot R_a$ OR $V = I_{sh} \cdot R_{sh}$

3. **Compound Generator** A compound generator is shown in figure below. It has two field windings namely R_{sh} and R_{se} . They are basically shunt winding (R_{sh}) and series winding (R_{se}).

Compound generator is of two types - 1) Short shunt and 2) Long shunt

a) **Short shunt:-** Here the shunt field winding is wired parallel to armature and series field winding is connected in series to the load. It is shown in fig (a).

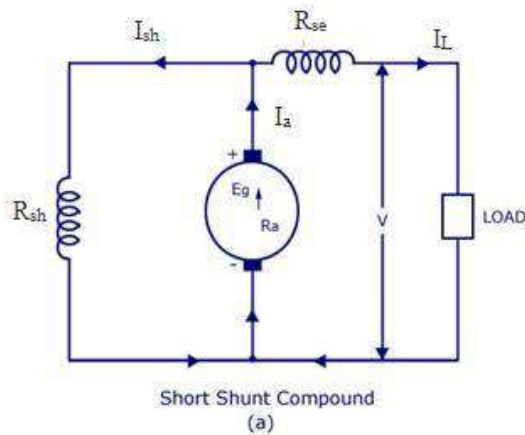

b) **Long shunt:-** Here the shunt field winding is parallel to both armature and series field winding (R_{se} is wired in series to the armature). It is shown in figure (b)

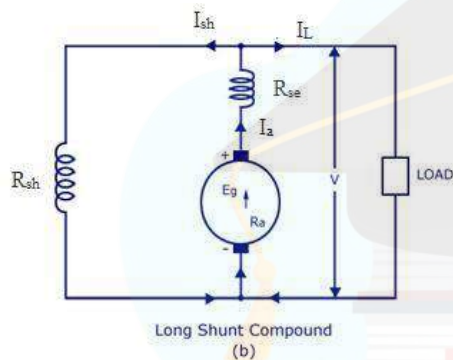

So you have got a basic idea about the types of DC generators! Now you may know that these generators are used only for special industrial purposes where there is huge demand for DC production. Otherwise, electrical energy is produced by AC generators and is transmitted from one place to other as AC itself. When a DC power is required, we usually convert AC to DC using rectifiers.

Application:- Shunt Generators:

- in electro plating ,for battery recharging , as exciters for AC generators.

Series Generators :

- As boosters , As lighting arc lamps **Shunt Motor:**

- Blowers and fans, Centrifugal and reciprocating pumps, Lathe machines, Milling machines, Drilling machines

Series Motor:

- Cranes, Hoists, Conveyors, Trolleys, Electric locomotives **Cumulative**

compound Motor:

- Rolling mills, Punches, Shears, Heavy planers, Elevators

Three Phase Induction Motor

Three-phase induction motors are the most common machines used in industry.

- simple design, rugged, low-price, easy maintenance.
- wide range of power ratings: fractional horsepower to 10 MW
- run essentially as constant speed from zero to full load.
- not easy to have variable speed control

◎ An induction motor has two main parts

1. **STATOR:** a stationary part of the motor is known as stator.

- It consists of a steel frame that supports a hollow, cylindrical core.
- The core, constructed from stacked laminations, having a number of slots, providing the space for the stator winding.

2. **ROTOR:** a revolving part of the motor is termed as rotor. It is composed of punched laminations, stacked to create a series of rotor slots, providing space for the rotor winding. there are two types of rotor windings used:

- a. Wound rotor: conventional 3-phase windings made of insulated wire, similar to the winding on the stator
- b. Squirrel cage rotor: An aluminum bus bars shorted together at the ends by two aluminum rings, forming a squirrel-cage shaped circuit.

◎ Two basic design types depending on the rotor design

- squirrel-cage
- wound-rotor

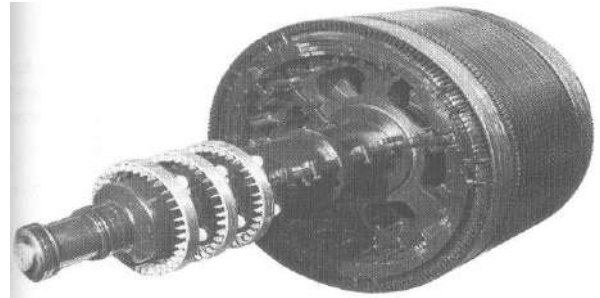
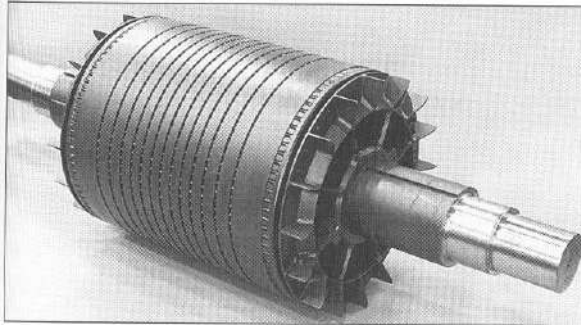

Principle of operation:-

When three phase ac supply is connected to 3 phase stator winding. A rotating magnetic field is produced in the air gap, rotating with a speed $N_s = 120f/P$. Where f is the supply frequency and P is the no. of poles and N_s is called the synchronous speed in rpm. This rotating magnetic field cuts the stationary rotor conductor and produces an induced voltage in the rotor windings

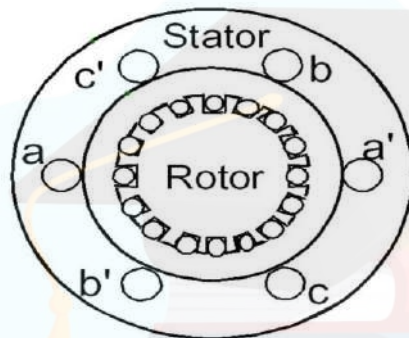

Due to the fact that the rotor windings are short circuited, so induced current flows in the rotor winding. According to Lenz's law this current tries to oppose the cause due to which it is produced, since the cause is relative motion between rotating magnetic field and stationary rotor conductor. So rotor starts rotating in same direction in which magnetic field rotate. The torque is produced as a result of the interaction of those two magnetic fields

$$\tau_{ind} \propto k B_R B_S$$

Where τ_{ind} is the induced torque and B_R and B_S are the magnetic flux densities of the rotor and the stator respectively.

Q.Can the Induction motor runs at the synchronous speed, why?

No, Induction motor does not run at synchronous speed. If rotor runs at the synchronous speed, which is the same speed of the rotating magnetic field, then the rotor will appear

stationary to the rotating magnetic field and the rotating magnetic field will not cut the rotor. So, no induced current will flow in the rotor and no rotor magnetic flux will be produced so no torque is generated and the rotor speed will fall below the synchronous speed. When the speed falls, the rotating magnetic field will cut the rotor windings and a torque is produced.

Slip:-

- ⦿ The Induction motor will always run at a speed lower than the synchronous speed
- ⦿ The difference between the motor speed and the synchronous speed is called the *Slip*. It is always expressed in percentage.

$$S = N_s - N_r$$

$$S = (N_s - N_r) / N_s ; \text{ Where } N_s = 120f/P$$

Where S = slip

N_s = Synchronous speed or speed of the magnetic field

N_r = speed of the motor.

The rotor current frequency or rotor frequency (f_r) is given by

$$F_r = s.f \text{ Hz}$$

Notice that: if the rotor runs at synchronous speed $s = 0$ if the rotor is stationary $s = 1$

Note: the slip is a ratio and doesn't have units

Torque-slip characteristics:-

The torque slip curve for an induction motor gives us the information about the variation of torque with the slip.

$$T = \frac{k s R_2 E_{20}^2}{R_2^2 + (sX_{20})^2} \dots \dots \dots (1)$$

$$N_r = N_s(1 - s)$$

At starting, $N_r = 0$ & $s=1$. the starting torque will act on motor.

When $N_r = N_s$ & $s=0$, Torque act on motor will be zero.

Torque-slip characteristic curve can be divided into three regions

- Low slip region ($T \propto s$)
- Medium slip region
- High slip region ($T \propto 1/s$)

The maximum torque is independent of the rotor resistance.

- The motor will produce maximum torque, when slip $s = R_2/X_{20}$.

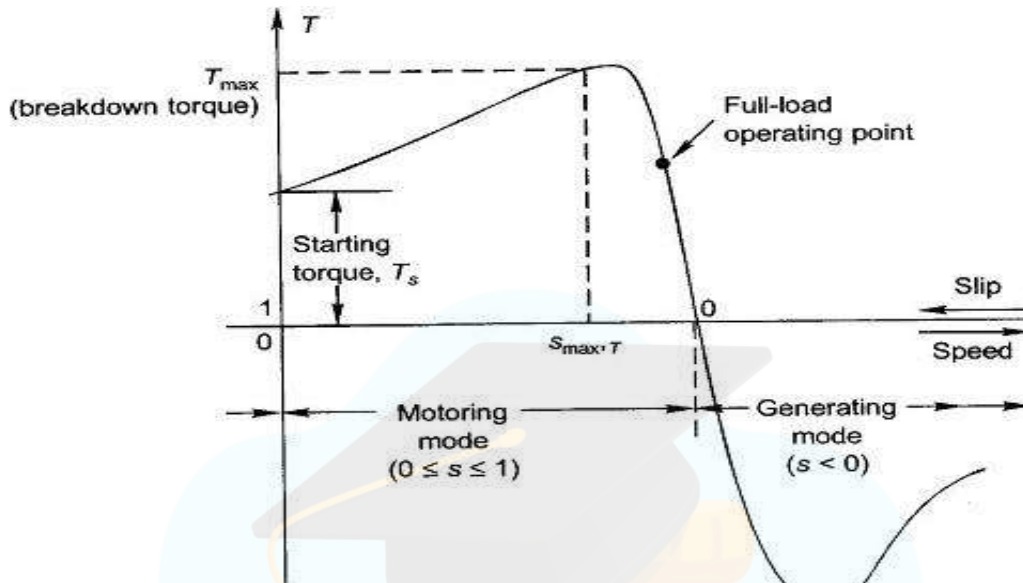

● **Motoring Mode**

In this mode of operation, the motor always rotates below the synchronous speed. The slip varies from zero to one. It is zero at no load and one at standstill. From the curve it is seen that the torque is directly proportional to the slip i.e. more is the slip, more will be the torque produced and vice-versa.

● **Generating Mode**

In this mode of operation induction motor runs above the synchronous speed. The torque and slip both are negative so the motor receives mechanical energy and delivers electrical energy.

Single Phase Induction Motor

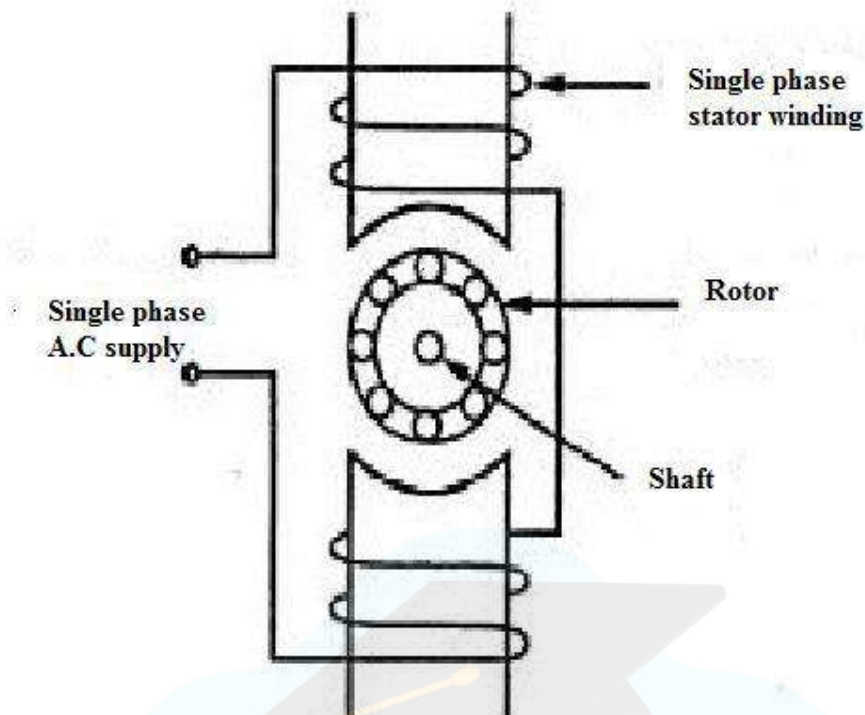
Principle:-

When we apply a single phase AC supply to the stator winding of single phase induction motor, the alternating current starts flowing through the stator or main winding. This alternating current produces an alternating flux called main flux. This main flux also links with the rotor conductors and hence cut the rotor conductors.

According to the Faraday's law of electromagnetic induction, emf gets induced in the rotor. As the rotor circuit is closed one so, the current starts flowing in the rotor. This current is called the rotor current. This rotor current produces its flux called rotor flux. Since this flux is produced due to the transformer action in opposite direction as of stator flux. Thus stator flux (Φ_s) always opposes rotor flux (Φ_r) in the same axis.

The torque angle between stator flux (Φ_s) and rotor flux (Φ_r) is 180° , hence no starting torque is developed.

$$T = \Phi_s \cdot \Phi_r \cdot \sin(180^\circ)$$

Thus Single Phase Induction Motor is not Self Starting.

Double revolving field theory:-

According to double field revolving theory, we can resolve any alternating quantity into two components. Each component has a magnitude equal to the half of the maximum magnitude of the alternating quantity, and both these components rotate in the opposite direction to each other. For example – a flux, ϕ can be resolved into two components

$$\frac{\phi_m}{2} \text{ and } -\frac{\phi_m}{2}$$

Each of these components rotates in the opposite direction i.e. if one $\Phi_m / 2$ is rotating in a clockwise direction then the other $\Phi_m / 2$ rotates in an anticlockwise direction.

When we apply a single phase AC supply to the stator winding of single phase induction motor, it produces its flux of magnitude, Φ_m . According to the double field revolving theory, this alternating flux, Φ_m is divided into two components of magnitude $\Phi_m / 2$. Each of these components will rotate in the opposite direction, with the synchronous speed, N_s .

Let us call these two components of flux as forwarding component of flux, Φ_f and the backward component of flux, Φ_b . The resultant of these two components of flux at any instant of time gives the value of instantaneous stator flux at that particular instant.

$$\text{i.e. } \phi_r = \frac{\phi_m}{2} + \frac{\phi_m}{2} \text{ or } \phi_r = \phi_f + \phi_b$$

Now at starting condition, both the forward and backward components of flux are exactly opposite to each other. Also, both of these components of flux are equal in magnitude. So, they cancel each other and hence the net torque experienced by the rotor at the starting condition is zero. So, the **single phase induction motors** are not self-starting motors.

Methods for Making Single Phase Induction as Self Starting Motor

From the above topic, we can easily conclude that the single-phase induction motors are not self-starting because the produced stator flux is alternating in nature and at the starting, the two components of this flux cancel each other and hence there is no net torque. The solution to this problem is that if we make the stator flux rotating type, rather than alternating type, which rotates in one particular direction only. Then the induction motor will become self-starting.

Now for producing this rotating magnetic field, we require two alternating flux, having some phase difference angle between them. When these two fluxes interact with each other, they will produce a resultant flux. This resultant flux is rotating in nature and rotates in space in one particular direction only.

Once the motor starts running, we can remove the additional flux. The motor will continue to run under the influence of the main flux only. Depending upon the methods for making asynchronous

motor as Self Starting Motor, there are mainly four **types of single phase induction motor** namely,

1. Split phase induction motor,
2. Capacitor start inductor motor,
3. Capacitor start capacitor run induction motor,
4. Shaded pole induction motor.
5. Permanent split capacitor motor or single value capacitor motor.

Starting methods of single phase induction motor:-

The single-phase induction motor is started by using some methods. Mechanical methods are not very practical methods that are why the motor is started temporarily by converting it into a two-phase motor. Single-phase induction motors are classified according to the auxiliary means used to start the motor. They are classified as follows:

1. Split-phase motor
2. Capacitor-start motor
3. Capacitor-start capacitor-run motor
4. Permanent-split capacitor (PSC) motor
5. Shaded-pole motor

1. Split-phase induction motor:

The split-phase induction motor is also known as a **resistance-start motor**. It consists of a single-cage rotor, and its stator has two windings, the main winding and a starting (also known as an auxiliary) winding. Both the windings are displaced by 90° in space like the windings in a two-phase induction motor. The main winding of the induction motor has very low resistance and high inductive reactance. Thus the current I_M in the main winding lags behind the supply voltage V by nearly 90° .

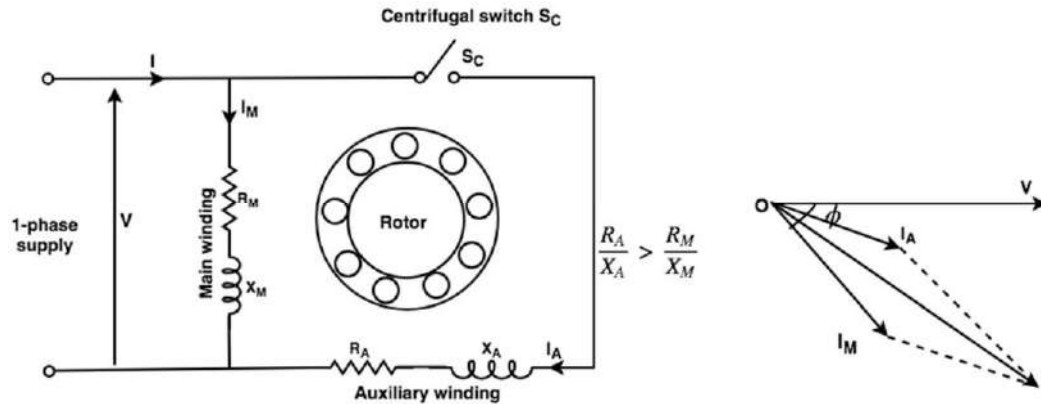

Figure: Split-phase induction motor (a) Circuit diagram (b) Phasor diagram

The starting winding has highly resistive and low inductive reactance. Thus I_A nearly in phase with supply voltage. Thus there is time difference between the currents in the two windings. This phase difference is enough for producing rotating magnetic field. As motor reaches 70-80 per cent of synchronous speed, starting winding disconnects from main winding using centrifugal switch.

Applications:

Split-phase motors are most suitable for easily started loads where the frequency of starting is limited, and these are very cheap.

1. These motors are used in washing machines.
2. These are used in Air conditioning fans.
3. Used in food mixers, grinders, floor polishers, blowers, centrifugal pumps,
4. These are used in small drills, lathes, office machinery, etc.
5. Sometimes they are also used for drives requiring more than 1kW.

Capacitor motors:

Capacitor motors are the motors that have a capacitor in the auxiliary winding circuit to produce a greater phase difference between the current in the main and auxiliary windings.

There are three types of capacitor motors.

2. Capacitor-start motor:

In this motor capacitor is connected in series with starting winding. The capacitor-start motor develops a much higher starting torque, i.e. 3.0 to 4.5 times the full-load torque. To obtain a high

starting torque, the value of the starting capacitor must be large, and the resistance of starting winding must be low. Because of the high VAR rating of the capacitor required, electrolytic capacitors of the order of 250 μF are used. The capacitor C_s is short-time rated. As motor reaches 70-80 % of rated speed, starting winding with capacitor automatically disconnected. These motors are more costly than split-phase motors because of the additional cost of the capacitor.

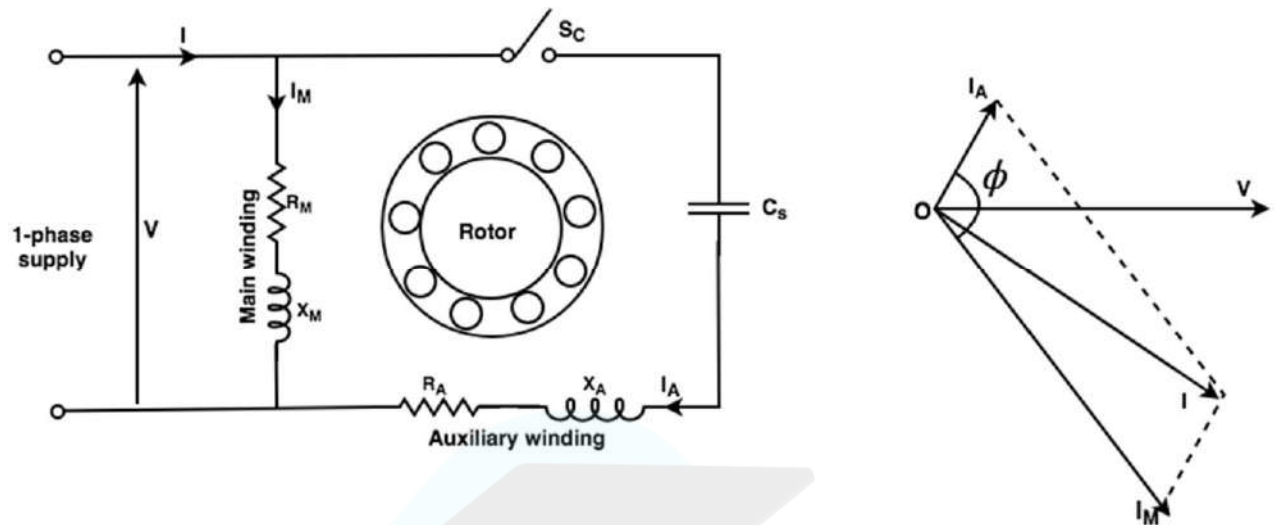

Figure: Capacitor start motor (a) circuit diagram (b) Phasor diagram

Applications:

1. These motors are used for heavy loads where frequent start required.
2. These motors are used for pumps and compressors, so these are used as a compressor in the refrigerator and air conditioner.
3. They are also used for conveyors and some machine tools.

3. Capacitor Start Capacitor Run Motor:-

This motor has a cage rotor, and its stator has two windings namely the main winding and the auxiliary winding. The two windings are displaced 90 in space. The motor use two capacitors C_s and C_R . Capacitor C_s is called starting capacitor and it is high value capacitor. It disconnects after reaching rated speed. C_R is called running capacitor of low value and connected throughout the operation. In the initial stage, the two capacitors are connected in parallel.

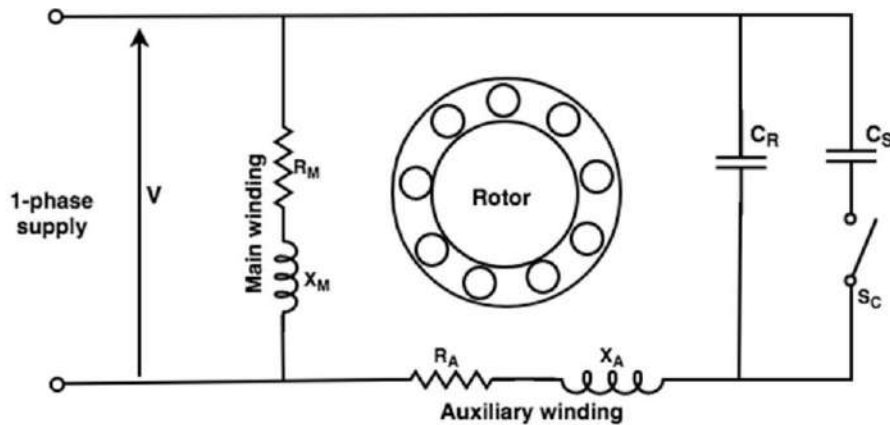

Applications:

1. Two value capacitor motors are used for loads of higher inertia that requires frequent start.
2. These are used in pumping equipment.
3. These are used in refrigeration, air compressors, etc.

4. Permanent-split Capacitor (PSC) motor:

These motors have a cage rotor, and its rotor consists of two windings namely, the main winding and the auxiliary winding. The single-phase induction motor has only one capacitor C which is connected in series with the starting winding. The capacitor C is permanently connected in series with the starting winding. The capacitor C is permanently connected in the circuit at starting and running conditions.

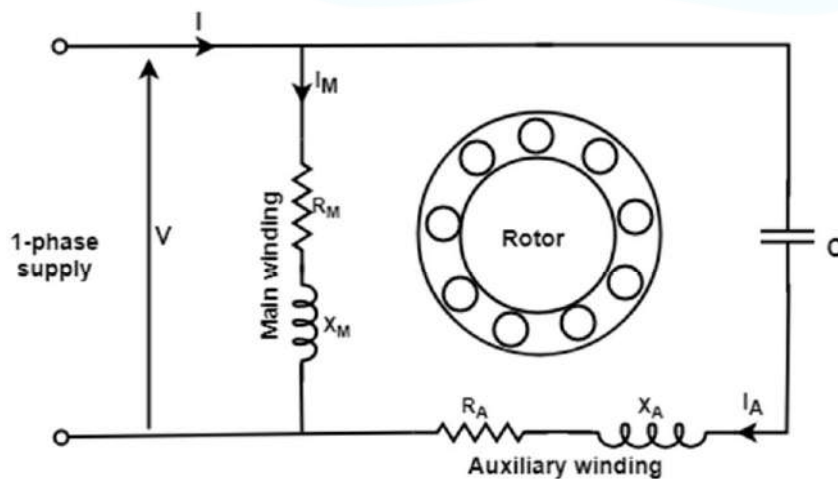

Figure: Permanent-split capacitor motor

Advantages: A single-value capacitor motor has the following advantages:

1. In this type of motor, no centrifugal switch is required.
2. This motor has higher efficiency.
3. It has higher power-factor because of a permanently-connected capacitor.
4. It has higher pull-out torque.

Limitations of permanent-split capacitor motor:

1. Electrolytic capacitors cannot be used for continuous running. Therefore, paper-spaced oil-filled type capacitors are to be used. Paper capacitors of the same rating are larger in size and more costly.
2. A single-value capacitor has a low starting torque usually less than full-load torque.

Applications:

1. These motors are used for fans and blowers in heaters.
2. It is used in air conditioners.
3. It is used to drive refrigerator compressors.
4. It is also used to operate office machinery.

5. Shaded pole motor:

A shaded-pole motor is a simple type of self-starting single-phase induction motor. It consists of a stator and a cage-type rotor. The stator is made up of salient poles. Each pole is slotted on the side, and a copper ring is fitted on the smaller part. This part is called the shaded pole. The ring is usually a single-turn coil and is known as shading coil.

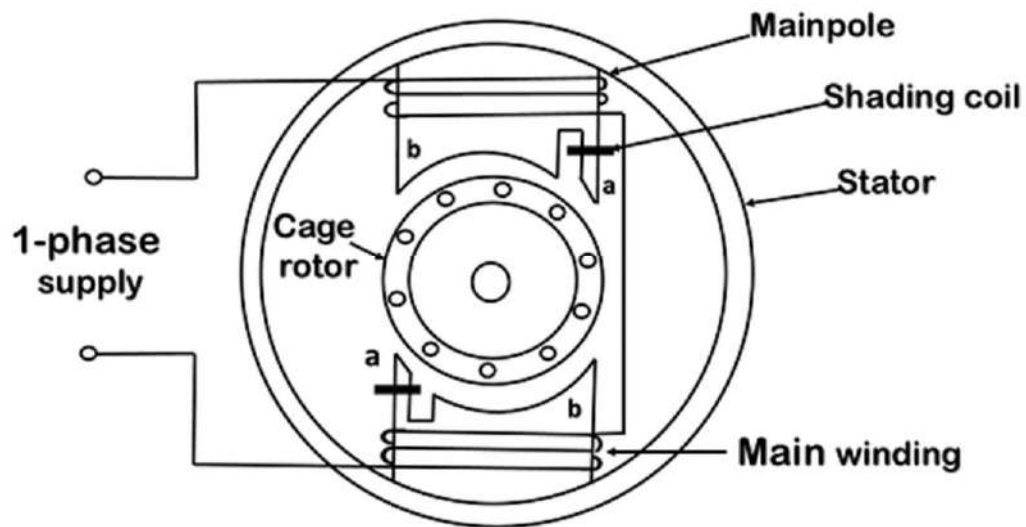

Figure: Shaded-pole motor with two stator poles.

Applications:

1. Shaded-pole motors are used to drive devices which require low starting torque.
2. These motors are very suitable for small devices like relays, fans of all kinds, etc. because of their low initial cost and easy starting.
3. The most common application of these motors is in table fans, exhaust fans, hair dryers, fans for refrigeration and air-conditioning equipment, electronic equipment, cooling fans, etc.

Synchronous machine

Synchronous motor is doubly excited machine. The stator winding is excited with 3 phase A.C supply and rotor winding with D.C supply respectively. When a three-phase supply is given to the stator of a three-phase wound synchronous motor, a rotating field is set up in the air gap which rotates at synchronous speed ($N_s = 120f/p$). This is represented by the imaginary stator poles.

The synchronous motor works on the principle of magnetic locking. The operating principle can be explained with the help of a 2-Pole synchronous machine with the following steps.

Let us consider a two-pole synchronous motor as shown in Figure. The three-phase supply is provided to the stator which induces two poles i.e North pole and the South pole on Stator. Since the supply in the stator is alternating in nature, therefore, its polarity changes in every half cycle, thus the poles of stator also changes after every half cycle.

The synchronous motor rotor is energized by the DC current. The field current (D.C Current) of the motor produces a steady-state magnetic field. Since the polarity of D.C current is fixed therefore the poles of rotor don't vary.

Therefore, there are two magnetic fields present in the machine. **Stator poles changes in every half-cycle whereas rotor poles remain the same.**

Step 1. When a three-phase supply is given to the stator winding, a rotating magnetic field is produced in the stator.

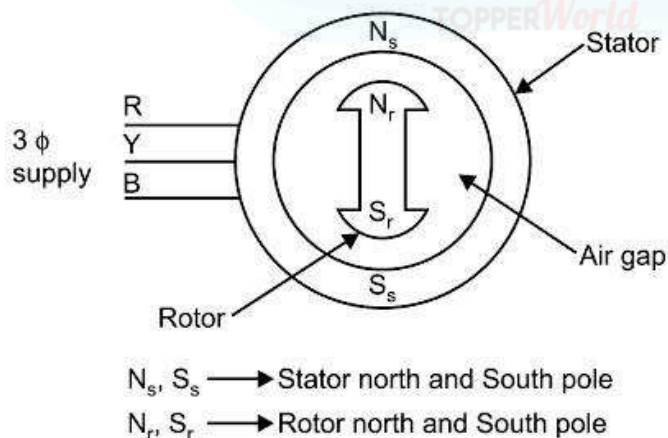

Step 2.

- Due to the Rotating Magnetic field, let the stator poles i.e North poles (N_s) and South Poles (S_s) rotate with synchronous speed.
- At a particular time stator pole, N_s coincides with the rotor poles N_r and S_s coincides with S_r i.e like poles of the stator and rotor coincide with each other.
- As we know, like poles experience a repulsive force. So rotor poles experience a repulsive force F_r . Let us assume that the rotor tends to rotate in the anti-clockwise direction as shown in Fig. (i).

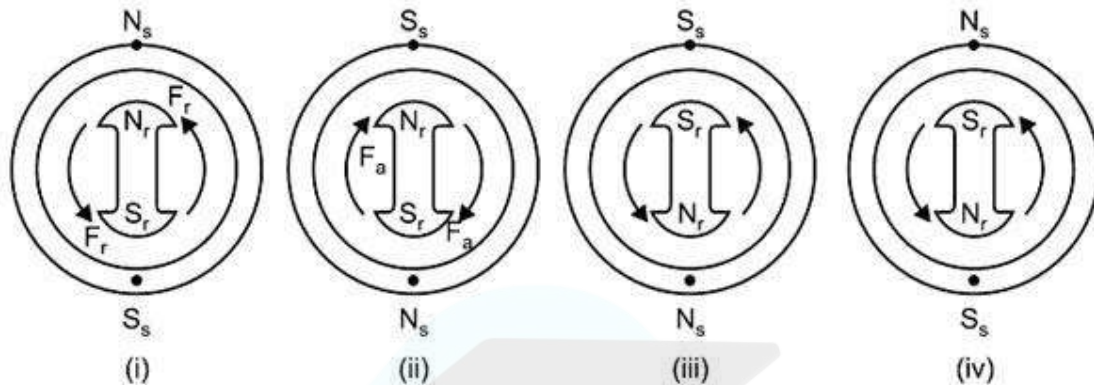

Step-3.

- After half cycle, the polarity of the stator pole is reversed, whereas the rotor poles cannot change their polarity as shown in Fig. (ii).
- Now unlike poles of rotor and Stator coincide with each other and rotor experiences the attractive force f_a and the rotor tends to rotate in the clockwise direction.
- In brief, we can say, with the rotation of stator poles the rotor tends to drive in the clockwise and anti-clockwise direction in every half cycle.
- Hence, to and fro motion is excited on the rotor and as a result, the rotor does not rotate. As a result, the average torque on the rotor is zero. **Hence the 3-phase synchronous motor is not a self-starting motor.**

Application:-

1. For constant speed application.
2. For improving power factor of substation.

MODULE 5: Electrical Installations

Contents: Components of LT Switchgear: Switch Fuse Unit (SFU), MCB, ELCB, MCCB, Types of Wires and Cables, Importance of earthing, Types of Batteries, Important characteristics for Batteries. Elementary calculations for energy consumption and savings, battery backup.

Components of LT Switchgear: Switch Fuse Unit (SFU), MCB, ELCB, MCCB:

Switchgear: The apparatus used for switching, controlling and protecting the electrical circuits and equipment is known as switchgear.

The term 'switchgear' is a generic term encompassing a wide range of products like circuit breakers, switches, switch fuse units, off-load isolators, HRC fuses, contactors, earth leakage circuit breaker, etc...

Classification of Switchgear:

Switchgear can be classified on the basis of voltage level into the following:

1. Low voltage (LV) Switchgear: upto 1KV
2. Medium voltage (MV) Switchgear: 3 KV to 33 KV
3. High voltage (HV) Switchgear: Above 33 KV

Components of LT Switchgear:
 The term LT Switchgear includes low voltage Circuit Breakers, Switches, off load electrical isolators, HRC fuses, Earth Leakage Circuit Breaker, Miniature Circuit Breakers (MCB) and Molded Case Circuit Breakers (MCCB) etc i.e. all the accessories required to protect the LV system.

The most common use of LV switchgear is in LV distribution board.

FUSE:

Fuse is perhaps the simplest and cheapest device used for interrupting an electrical circuit under short circuit, or excessive overload, current magnitudes. The action of a fuse is based upon the heating effect of the electric circuit. The fuse has inverse time-current characteristics as shown in the next slide. The part which actually melts and opens the circuit is known as the fuse element.

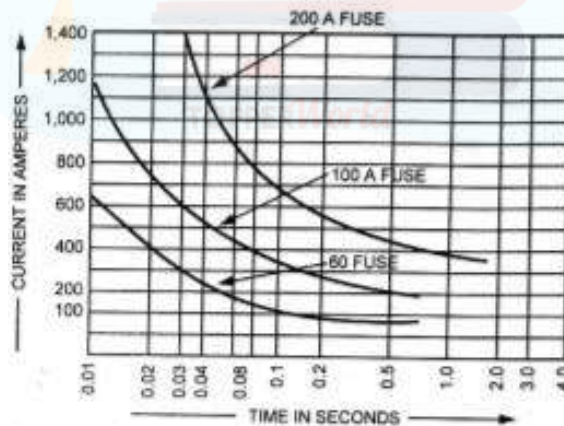

Time-Current Characteristics

Fuses have following advantages and disadvantages: **Advantages:**

1. It is cheapest form of protection available.
2. It needs no maintenance.
3. Its operation is inherently completely automatic unlike a circuit breaker which requires an elaborate equipment for automatic action.

4. It interrupts enormous short circuit currents without noise, flame, gas or smoke.

Disadvantages:

1. Considerable time is lost in rewiring or replacing a fuse after operation.
2. On heavy short circuits, discrimination between fuses in series cannot be obtained unless there is considerable differences in the relative sizes of the fuse concerned.
3. The current-time characteristics of a fuse cannot always be correlated with that of the protected device.

FUSE: *Fuse is provided only in phase or live pole, never on neutral pole.*

FUSE UNITS: The various types of fuse units, most commonly available are:

1. Round type fuse unit.
2. Kit-kat type fuse unit.
3. Cartridge type fuse unit.
4. HRC (High Rupturing Capacity) fuse units and 5. Semiconductor fuse units.

1. Round type fuse unit: This type of fuse unit consists of a porcelain or bakelite box and two separated wire terminals for holding the fuse wire between them. This type of fuse is not common use on account of its following disadvantages:

- One of the terminals remain always energized and, therefore, for replacement of fuse either the worker will have to touch the live mains or open the main switch.
- Appreciable arcing takes place at the instant of blowing off fuse and thus damage the terminals. After two or three arcing the fuse unit becomes unusable.

2. Rewirable or Kit-kat Type Fuses: The most commonly used fuse in “house wiring” and small current circuits is the semi-enclosed or rewirable fuse (also sometimes known as kitkat type fuse). It consists of a porcelain base carrying the fixed contacts to which the incoming and outgoing live or phase wires are connected and a porcelain fuse carrier holding the fuse element, consisting of one or more strands of fuse wire, stretched between its terminals.

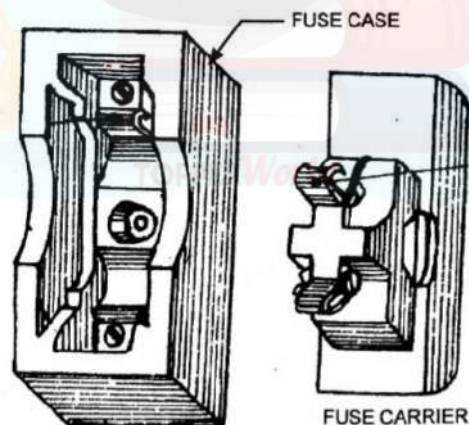

The fuse wire may be of lead, tinned copper, aluminium or an alloy of tin-lead. The actual fusing current will be about twice the rated current.

The specifications for rewirable fuses are covered by IS: 2086-1963. Standard ratings are 6, 16, 32, 63 and 100A. A fuse wire of any rating not exceeding the rating of the fuse may be used in it i.e. a 80A fuse wire can be used in a 100A fuse, but not in the 63A fuse.

Disadvantages of Rewirable or Kit-kat Type Fuses:

- Unreliable operation.
- Lack of discrimination.
- Small time lag.

- Low rupturing capacity.
- No current limiting feature.
- Slow speed of operation.

3. **Cartridge Type Fuses:** This is a totally enclosed type fuse unit. It essentially consists of an insulating container of bulb or tube shape and sealed at its ends with metallic cap known as cartridge enclosing the fuse element and filled with powder or granular material known as filler.

There are various types of materials used as filler like sand, calcium carbonate, quartz etc. This type of fuse is available upto 660V and the current rating upto 800 A.

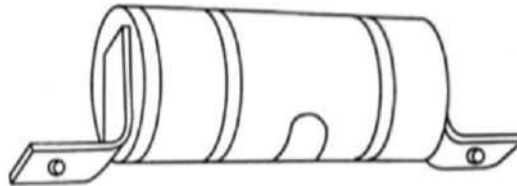

4. **High Rupturing Capacity (HRC) Fuses:** With a very heavy generating capacities of the modern power stations, extremely heavy currents would flow into the fault and fuse clearing the fault would be required to withstand extremely high stresses in this process. HRC fuses developed and designed after intensive research for use in medium and high voltage installations. Their rupturing capacity is as high as 500MVA upto 66 KV and above.

There are basically two types of HRC fuses are used.

1. Cartridge Type HRC Fuse.
2. Tetra Chloride Type HRC Fuse.

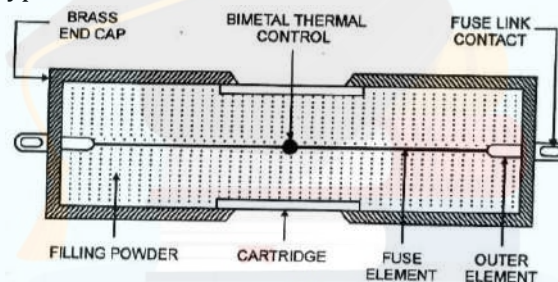

5. **Semiconductor Fuses:** These are very fast acting fuses for protection of thyristor and other electronic circuits.

Switch Fuse Unit (SFU):

Switch fuse is a combined unit and is known as an iron clad switch, being made of iron. It may be double pole for controlling single phase two-wire circuits or triple pole for controlling three-phase, 3-wire circuits or triple pole with neutral link for controlling 3-phase, 4-wire circuits. The respective switches are known as double pole iron clad (DPIC), triple pole iron clad (TPIC), and triple pole with neutral link iron clad (TPNIC) switches.

1. **For Two-wire DC Circuits or Single Phase AC Circuits:** 240V, 16A, DPIC switch fuse
2. **For Three-Wire DC Circuits:** 500V, 32A (63/100/150 or higher amperes), IS approved TPIC switch fuse.
3. **For Three-Phase Balanced Load Circuits:** 415V, 32A (63/100/150 or higher amperes), IS approved TPIC switch fuse.

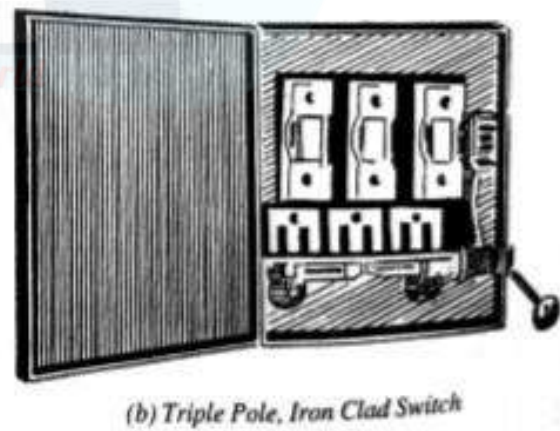
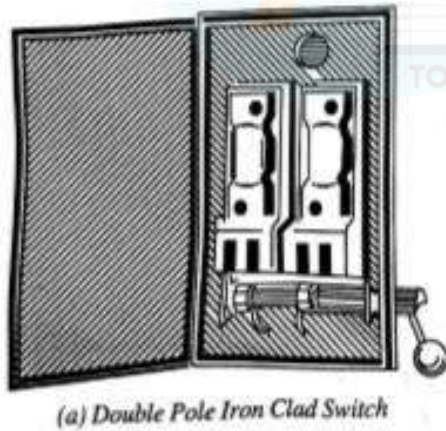
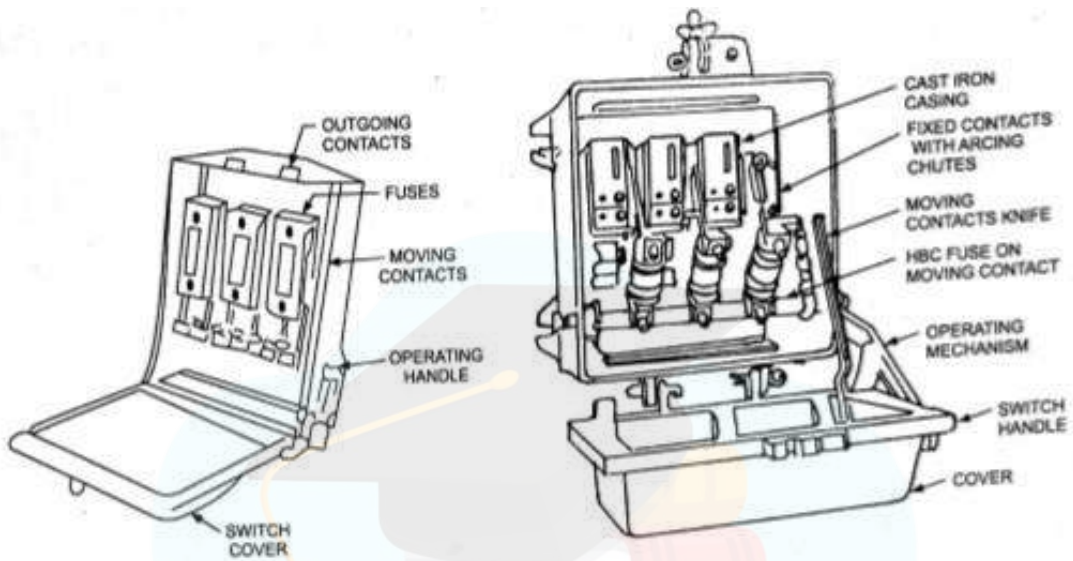
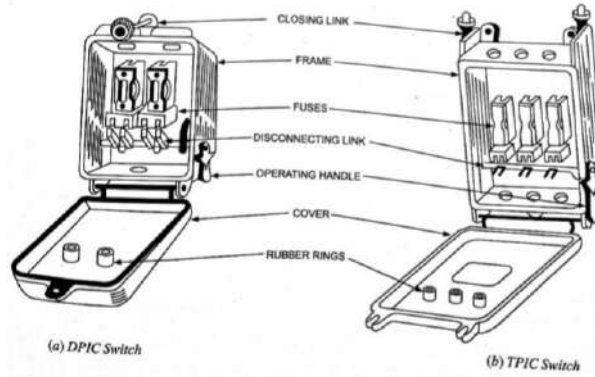

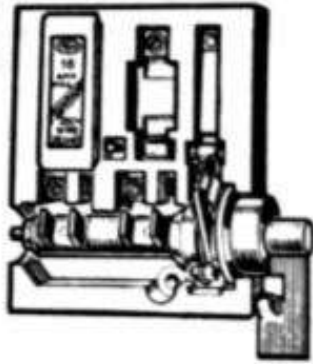

(c) 16-Amp. All insulated Main Switch



(d) All insulated Switch With Moulded Cover and Base For Circuits Up to 16 Amperes Capacity

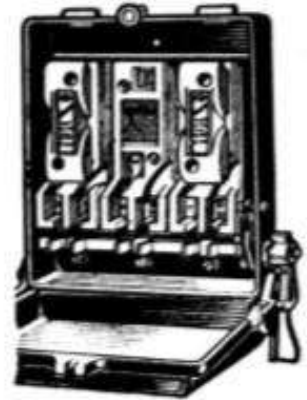

(e) Three-Phase Iron Clad Main Switch For Power Use

Miniature Circuit Breaker (MCB):

A device which provides definite protection to the wiring installations and sophisticated equipment against over-currents and short-circuit faults. Thermal operation (overload protection) is achieved with a bimetallic strip, which deflects when heated by any over-currents flowing through it. In doing so, releases the latch mechanism and causes the contacts to open. Inverse-time current characteristics result. i.e. greater the overload or excessive current, shorter the time required to operate the MCB. On occurrence of short circuit, the rising current energizes the solenoid, operating the plunger to strike the trip lever causing immediate release of the latch mechanism. Rapidity of the magnetic solenoid operation causes instantaneous opening of contacts.

MCBs are available with different current ratings of 0.5, 1.2, 2.5, 3, 4, 5, 6, 7.5, 10, 16, 20, 25, 32, 35, 40, 63, 100, 125, 160 A and voltage rating of 240/415 V AC and up to 220 V DC. Operating time is very short (less than 5 ms).

They are suitable for the protection of important and sophisticated equipment, such as airconditioners, refrigerators, computers etc.

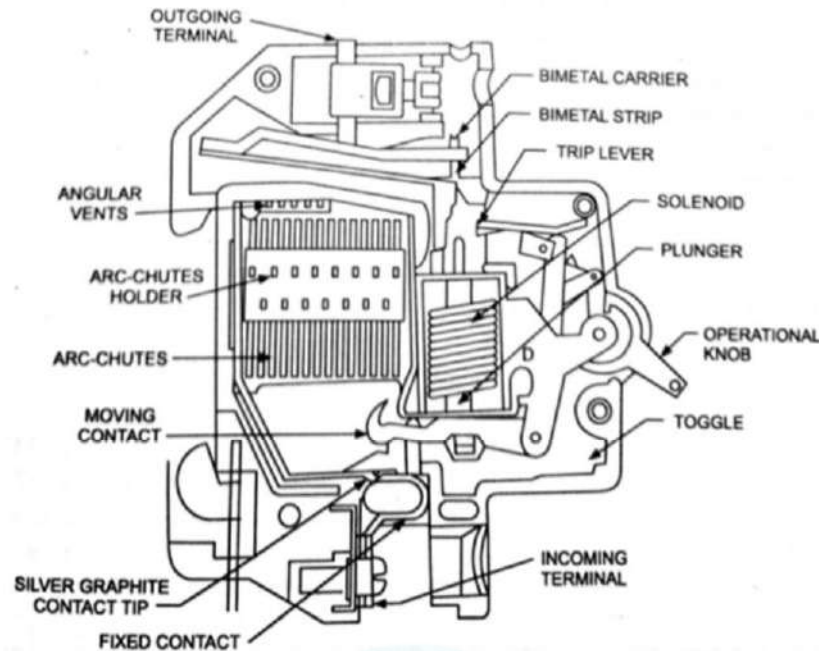

Earth Leakage Circuit Breaker (ELCB):

It is a device that provides protection against earth leakage. These are of two types.

1. **Current operated earth leakage circuit breaker:**
2. **Voltage operated earth leakage circuit breaker.**

1. Current operated earth leakage circuit breaker: It is used when the product of the operating current in amperes and the earth-loop impedance in ohms does not exceed 40. Such circuit breakers are used where consumer's earthing terminal is connected to a suitable earth electrode. A current-operated earth leakage circuit breaker is applied to a 3-phase, 3-wire circuit.

In normal condition when there is no earth leakage, the algebraic sum of the currents in the three coils of the current transformers is zero, and no current flows through the trip coil. In case of any earth leakage, the currents are unbalanced and the trip coil is energized, thus the circuit breaker is tripped.

2. Voltage operated earth leakage circuit breaker: It is suitable for use when the voltage between the earth continuity conductor (ECC) and earth electrode rises to sufficient value, the trip coil will carry the required current to trip the circuit breaker. With such a circuit breaker the earthing lead between the trip coil and the earth electrode must be insulated; in addition, the earth electrode must be placed outside the resistance area of any other parallel earths which may exist.

2. Voltage operated earth leakage circuit breaker: It is suitable for use when the earth-loop impedance exceeds the values applicable to fuses or excess-current circuit breaker or to current operated earth leakage circuit breaker. When the voltage between the earth continuity conductor (ECC) and earth electrode rises to sufficient value, the trip coil will carry the required current to trip the circuit breaker. With such a circuit breaker the earthing lead between the trip coil and the earth electrode must be insulated; in addition, the earth electrode must be placed outside the resistance area of any other parallel earths which may exist.

In both the above types of ELCB the tripping operation may be tested by means of a finger-operated test button which passes a predetermined current from the line wire through a

high resistance to trip the coil and thus to earth. This test operation should be performed regularly.

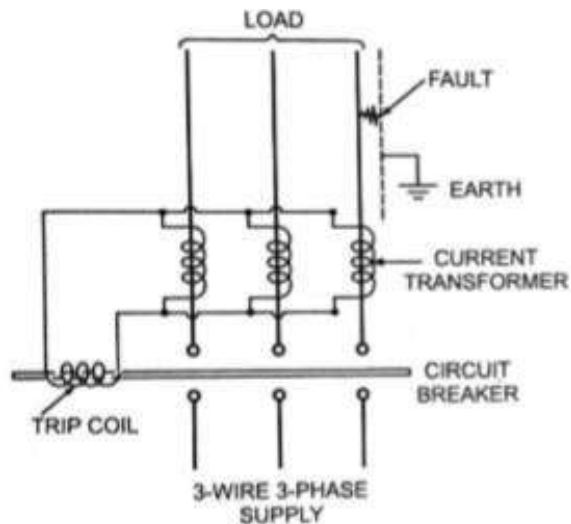

Fig: Current Operated ELCB

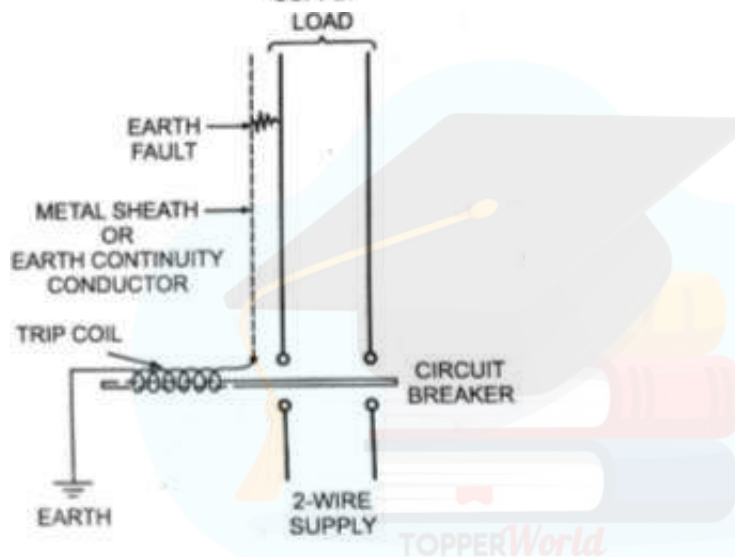

Fig: Voltage Operated ELCB

Molded Case Circuit Breaker (MCCB) :

It is a type of electrical protection device that can be used for a wide range of voltages, and frequencies of both 50 Hz and 60 Hz, the main distinctions between molded case and miniature circuit breaker are that MCCB can have current rating up to 2500 amperes, and its trip setting are normally adjustable. MCCBs are much larger than MCBs. An MCCB has three main functions:

- **Protection against overload.**
- **Protection against electrical faults.**
- **Switching a circuit ON and OFF.** This is a less common function of circuit breakers, but they can be used for that purpose if there is not an adequate manual switch.

The wide range of current ratings available from molded-case circuit breakers allows them to be used in a wide variety of applications. MCCBs are available with current ratings that range from low values such as 15 amperes, to industrial ratings such as 2500 amperes. This allows them to be used in both low power and high power applications.

Operating Mechanism: At its core, the protection mechanism employed by MCCBs is based on the same physical principles used by all types of thermal-magnetic circuit breakers.

- Overload protection is accomplished by means of a thermal mechanism. MCCBs have a bimetallic contact that expands and contracts in response to changes in temperature. Under normal operating conditions, the contact allows electric current through the MCCB. However, as soon as the current exceeds the adjusted trip value, the contact will start to heat and expand until the circuit is interrupted.
- The thermal protection against overload is designed with a time delay to allow short duration overcurrent, which is a normal part of operation for many devices. However any over current conditions, that lasts more than what is normally expected represent an overload, and the MCCB is tripped to protect the equipment and personnel. On the other hand, fault protection is accomplished with electromagnetic induction, and the response is instant. Fault currents should be interrupted immediately, no matter if their duration is short or long. Whenever a fault occurs, the extremely high current induces a magnetic field in a solenoid coil located inside the breaker-this magnetic induction trips a contact and current is interrupted. As a complement to the magnetic protection mechanism, MCCBs have internal arc dissipation measures to facilitate interruption.



Types of Wires and Cables:

For internal wiring of any building, wires and cables may be categorized into following groups:

1. **Conductor Used:** According to conductor material used in the cables, these may be divided into two classes known as copper conductor cables and aluminium conductor cables.
2. **Number of Cores Used:** It may be divided into different classes known as: single core cables, twin core cables, three core cables, two core with ECC (Earth Continuity Conductor) cables etc.
3. **Voltage Grading:** According to voltage grading the cables may be divided into two classes (i) 250/440 Volt cables and (ii) 650/1100 volt cables
4. **Types of Insulation Used:** According to type of insulation the cables are of following types:
 - Vulcanized Indian Rubber (VIR) insulated cables
 - Tough Rubber Sheathed (TRS) or Cab Tyre Sheathed (CTS) cables.
 - Lead Sheathed Cables.
 - Polyvinyl Chloride (PVC) Cables.
 - Weatherproof cables.
 - Flexible cords and cables.
 - XLPE cables.
 - Multi-strand cables.

- **Vulcanized Indian Rubber (VIR) insulated cables:** VIR cables are available in 240/415 volts as well as in 650/1100 volt grades. VIR cables consists of either Tinned copper conductor Covered with a layer of VIR insulation. Over the rubber Insulation cotton tape sheathed Covering is provided with Moisture resistant compound bitumen wax or some other insulating material for making the cables moisture proof.

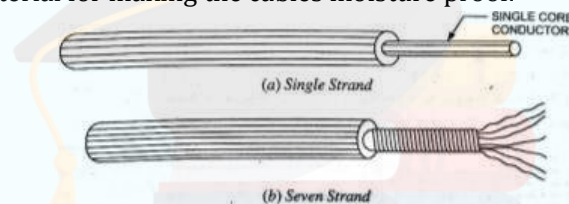
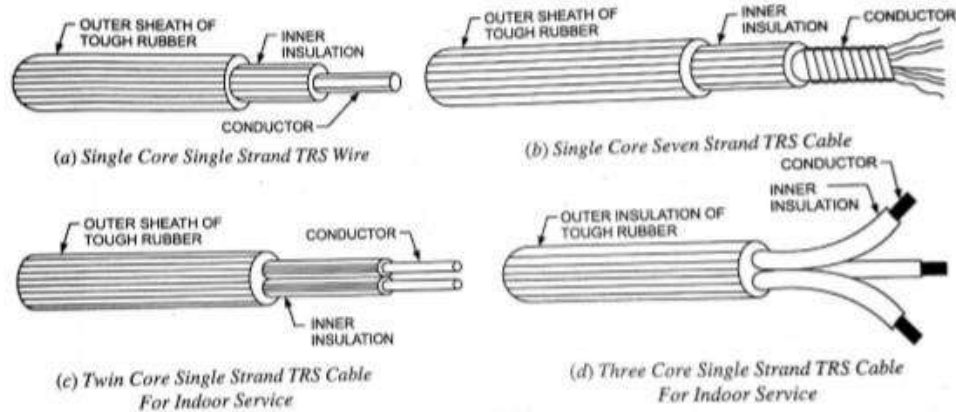

Figure: Single Core VIR Cables

- **Tough Rubber Sheathed (TRS) or Cab Tyre Sheathed (CTS) cables:** These cables are available in 250/440 volt and 650/1100 volt grades and used in CTS (or TRS) wiring. TRS cable is nothing but a VIR conductor with an outer protective covering of tough rubber, which provides additional insulation and protection against wear and tear. These cables are waterproof, hence can be used in wet conditions. These cables are available as single core, circular twin core, circular three core, flat three core, twin or three core with an earth continuity conductor. The core are insulated from each other and covered with a common sheathing.

These cables are cheaper in cost and lighter in weight than lead alloy sheathed cables and have the alloy sheathed cables and have the properties similar to those of lead sheathed cables and thus provide cheaper substitute to lead sheathed cables.



- **Lead Sheathed Cables:** These cables are available in 240/415 volt grade. The lead sheathed cable is a vulcanized rubber insulated conductor covered with a continuous sheath of lead. The lead sheath provides very good protection against the absorption of moisture and sufficient protection against mechanical injury and so can be used without casing or conduit system. It is available as a single core, flat twin core, flat three core and flat twin or three core with an earth continuity conductor. Two-core lead sheathed cable is shown in the given figure.

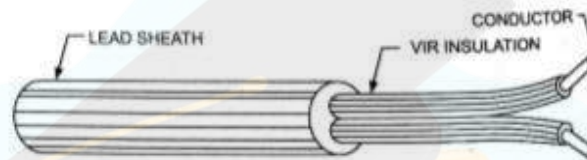

- **Polyvinyl Chloride Insulated Cables:** These cables are available in 250/440 volt and 650/1100 volt grades and are used in casing-capping, batten and conduit wiring system. In this type of cable, conductor is insulated with PVC insulation. Since PVC is harder than rubber, PVC cable does not require cotton taping and braiding over it for mechanical and moisture protection. PVC insulation is preferred over VIR insulation because of the following reasons:
 - PVC insulation has better insulating qualities.
 - PVC insulation provides better flexibility.
 - PVC insulation has no chemical effect on metal of the wire.
 - Thin layer of PVC insulation will provide the desired insulation level.
 - PVC coated wire gives smaller diameter of cable and, therefore, more no. of wires can be accommodated in the conduit of a given size in comparison to VIR or CTS wires.

PVC cables are most widely used for internal wiring these days. Though the insulation resistance of PVC is lower than that of VIR but its effect is negligible for low and medium voltages, below 600 V.
- **Weather Proof Cables:** These cables are used for outdoor wiring and for power supply or industrial supply. These cables are either PVC insulated or vulcanized rubber insulated conductors being suitably taped braided and then compounded with weather resisting material. These cables are available in 240/415 volt and 650/1100 volt grades. These cables are not affected by heat or sun or rain. Weather proof cables are shown in the given figure:

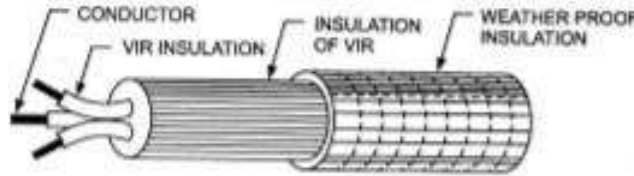

- **Flexible Cords and Cables:** The flexible cords consist of wires silk/cotton/plastic covered. Plastic cover is popular as it is available in different pleasing colours. Flexible cords have tinned copper conductors. Flexibility and strength is obtained by using conductors having large no. of strands. These wires or cables are used as connecting wires for such purposes as from ceiling rose to lamp holder, socket outlet to portable apparatus such as radios, fans, lamps, heaters etc. These must not be used for fixed wiring.

The flexible cords used for household appliances are available in various sizes and in various thickness of coating as very thin/thin/medium/thick/very thick/extra thick etc.

- **XLPE Cables:** PVC and XLPE cables are built of insulation made of polymers. Polymers are substances consisting of long macromolecules built up of small molecules or group of molecules as repeated units. These are divided into homopolymers and copolymers. Homopolymers are built by reactions of identical monomers. Copolymers are built up of at least two different kinds of monomers.

The mechanical properties of the polymers e.g. tensile strength, elongation elasticity, and resistance against cold depend upon chemical structure. Their resistance against external chemical influences, acids, bases or oils together with their electrical and thermal characteristics are the decisive factors for the usefulness of cables insulated and sheathed with these materials.

- **Multi-Stranded Cables:** Multi-stranded cables have got the following advantages with respect to the single solid conductor and hence preferred.
 - The multi-stranded cables are more flexible and durable and, therefore, can be handled conveniently.
 - The surface area of multi-strand cable is more as compared to the surface area of equivalent single solid conductor, so heat radiating capacity being proportional to the surface area is more.
 - Skin effect is better as the conductors are tubular, especially in the case of high frequency.

Importance of earthing:

An electrical equipment or appliance is said to be earthed, if its outer frame and its other parts not carrying any current are connected to the earth so as to attain as nearly zero potential as possible. In practice, all equipments and machinery, as well as electric poles, towers, neutral wires, etc, are earthed. The purpose of earthing is to ensure that all parts of the system other than live parts are maintained at the earth potential at all times.

Objective of Earthing:

1. The main objective of earthing is to provide safety of operation.
2. Another objective of the earthing, though not widely used nowadays, is to save conducting material.

3. It also helps in protecting high-rise buildings from atmospheric lightening. A fork metal rod or thick wire, called the lightening conductor, sticks out from the top of the building, chimney, tower, etc. its other end buried deep into the ground. Whenever lightening occurs, the electricity passes directly from the top of lightening conductor to the earth, thereby protecting the building from any damage.

Methods of Earthing: Earthing should be done in a way so that on a short circuit, the earth loop impedance is low enough to pass 3 times the current if fuses are used, and 1.5 times the current if MCBs are used. The metal work should be solidly earthed without using any switch or fuse in the circuit.

For effective earthing, the resistance offered by the earth electrode along with the soil in which electrode is embedded should be quite low.

Galvanised Iron (GI) or copper is used to make an earth electrode.

There are different types of earthing methods are used:

1. Strip or Wire Earthing.
2. Rod Earthing.
3. Pipe Earthing.
4. Plate Earthing.

Pipe and Plate Earthings are commonly used.

1. **Strip or Wire Earthing:** In this system of earthing, strip electrodes of cross section not less than 25 mm X 1.6 MM if of copper and 25 mm X 4 mm if of galvanized iron or steel are buried in horizontal trenches of minimum depth 0.5 metre. If round conductors are used, their cross-sectional area shall not be smaller than 3.0 mm² if of copper and 6 mm² if of galvanized iron or steel. The length of buried conductor shall be sufficient to give the required earth resistance. It shall, however, be not less than 1.5 metres.

This type of earthing is used at places which have rocky soil earth bed because at such places excavation work of plate earthing is difficult.

2. **Rod Earthing:** In this type of earthing, 12.5 mm diameter solid rods of copper or 16 mm diameter solid rods of galvanized iron or steel or hollow section 25 mm GI pipes of length not less than 2.5 metres are driven vertically into the earth either manually or by pneumatic hammer. In order to increase the embedded length of electrodes under the ground, which is sometimes necessary to reduce the earth resistance to desired value, more than one rod sections are hammered one above the other.

This system of earthing is suitable for areas which are sandy in character. This system of earthing is very cheap as no excavation work is involved.

3. **Pipe Earthing:** In the given figure, a GI pipe with a few holes at its lower end is buried to a depth not less than 2 m and atleast 0.6 m away from the foundation of any building. Normally, the size of pipe is either 2m long and 38 mm diameter or 1.37 m long and 51 mm diameter. However, for dry and rocky soil, we use longer pipes. Alternate layers of common salt and charcoal have thickness of 30 mm and 80 mm, respectively.

To maintain good conductivity of the soil, an arrangement is made for pouring water into the earth pit surrounding the earth electrode. This is especially needed during summer. As the pipe has much larger contact area with soil, it can handle larger leakage currents than the plate earthing of same electrode size. The earth wire (made of copper) is tightly fastened to the earth electrode by means of nut and bolt.

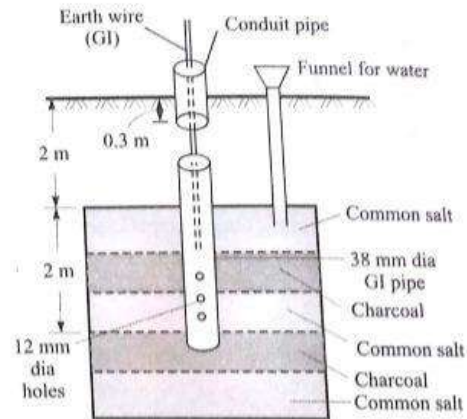

(b) Pipe earthing.

4. **Plate Earthing:** This is another common system of earthing. In plate earthing an earthing plate either of copper of dimensions 60cm X 60cm X 3mm or of GI of dimensions 60cm X 60cm 6mm is buried into the ground with its face vertical at a depth of not less than 3 metres from ground level. The earth plate is embedded in alternate layers of coke and salt for a minimum thickness of 15cm. The earth wire (GI wire for GI plate earthing and copper wire for copper plate earthing) is securely bolted to an earth plate with the help of a bolt, nut and washer made of material of that of earth plate. A small masonry brick wall enclosure with a cast iron cover on top or an RCC pipe round the earth plate is provided to facilitate its identification and for carrying out periodical inspection and tests.

The copper plate and copper wire are usually not employed for grounding because of their higher cost.

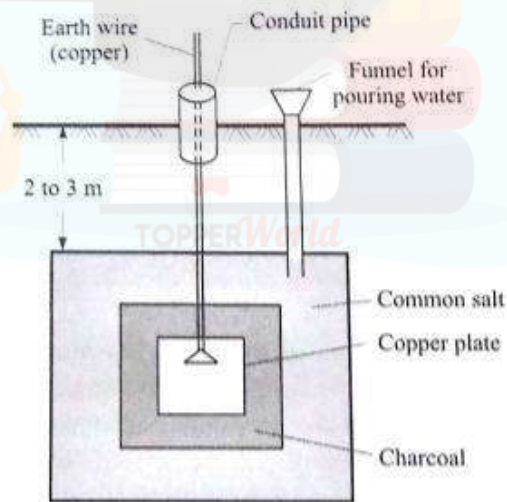

(a) Plate earthing.

Double Earthing: For providing better safety, it is advisable to provide two separate earth wires, from two separate earth electrodes, connected to same metallic body of the equipment at two different points. This is known as double earthing. Double earthing is essential, as per Indian Electricity Rule, for metallic bodies of large rating equipment such as transformer, motors etc. working at 400 V and above. Advantages of Double Earthing:

1. Surety of safety, because if at any time one earthing is ineffective, then another will provide earth path to fault.

2. As the two earth wires are in parallel so the effective resistance from equipment to earth electrode is reduced.

Types of Batteries, Important characteristics for Batteries:

Types of Batteries: There are two types of batteries which are given below:

1. **Primary Battery:** Primary batteries can be used only once because the chemical reactions that supply the current are irreversible. Primary batteries are the most common batteries available today because of their low cost and simplicity in use. Carbon-zinc dry cells and alkaline cells dominate portable consumer battery applications where currents are low and usage is sporadic. Other primary batteries such as those using mercury or lithium-based chemistries, may be used in applications when high energy densities, small sizes, or long shelf life are especially important. In general, primary batteries have dominated two areas: consumer products where the initial cost of the battery is very important and electronic products (such as watches, hearing aids and pacemakers) where drains are low or recharging is not feasible.
 2. **Secondary Battery:** Secondary batteries, sometimes called *storage batteries or accumulators*, can be used, recharged and reused. In these batteries, the chemical reactions that provide current from the battery are readily reserved when current is supplied to the battery. The process of inducing or storing energy in an accumulator is called the charging, and the process of giving out energy in the form of an electric current, the discharging. Accumulators or storage batteries owe their name "secondary" due to the fact that they can supply electrical energy only after they have been charged. Secondary batteries, which are rechargeable, have traditionally been most widely used in industrial and automotive applications. Only two rechargeable battery chemistries, lead acid and nickel-cadmium, have to-date, achieved significant commercial success. There are several types of secondary batteries are given below:
 - **Lead Acid Batteries:** Lead acid batteries, according to service rendered by them, are classified into *automotive, motive power and stationary batteries*.
 - **Nickel-Iron (OR Edison) Batteries:** These batteries are going to become more and more popular as there is a possibility of their development into high energy density batteries for electric vehicles.
 - **Nickel-Cadmium Accumulators:**
 - **Nickel-Metal Hydride Cells:**
1. **Lead Acid Batteries:**

Charging and Discharging Curves: Typical charge and discharge curves (variation in terminal voltage) of a lead-acid accumulator are as follows:
When the cell is charged, the voltage of the Cell increases from 1.8V to 2.2V during first two hours, then increases very slowly, rather remains almost constant for Sufficient time and finally rises to 2.5 to 2.7V.

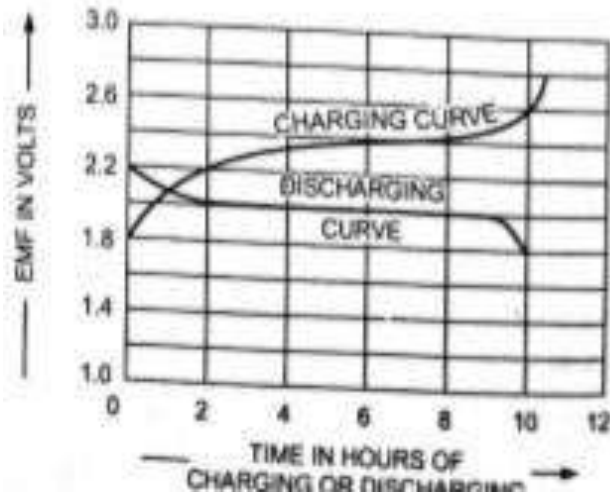

Caution: The cell should never be allowed to discharge beyond 1.75V otherwise lead sulphate will be formed on the electrodes which is hard, insoluble and increases the internal resistance of the cell. The conversion of active material into lead sulphate is termed sulphatization.

2. Nickel-Iron (OR Edison) Batteries:

Charge and Discharge Curve: The given figure shows how the voltage of a nickel-iron cell varies during charging and discharging. The emf, when fully charged, is about 1.4V, decreases to 1.3V rapidly and then slowly to 1.1 or 1.0V of discharge. An average discharge voltage is about 1.2V. The average charging voltage is about 1.7V per cell. The voltage characteristics are similar to those of a lead-acid cell. There is no lower limit to the voltage of the Edison cell because in it there is nothing like sulphation, but discharge is not continued below a useful lower limit. The emf of the cell or battery increases slightly with the temperature. Due to comparatively high internal Resistance, the efficiency of the Edison batteries are lower than those of the lead-acid batteries.

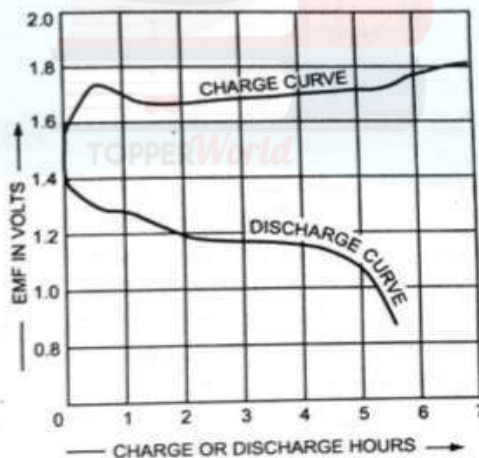

The ampere-hour and watt-hour efficiencies of the Edison batteries are about 80 per cent and 60 per cent respectively. Average energy density is about 50Wh per kg of cell. When assembling batteries for the same voltage, the number of nickel-iron cells required are more than that of lead-acid cells. For example, a 12V lead-acid battery will need $12/2$ i.e. 6 series-connected cells, whereas the nickel-iron battery will require $12/1.2$ i.e. 10 series-connected cells to give the same voltage i.e. 12V.

Application: These batteries are used for the propulsion of industrial trucks, and mine locomotives and for railway car lighting and air-conditioning because of their rugged construction and other advantages.

Important characteristics for Batteries:

Electrical Characteristics:

There are three important characteristics of an accumulator (or storage battery) namely,

- Voltage
- Capacity and
- Efficiency

1. Voltage: Average emf of cell is approximately 2.0 volts. The value of emf of a cell does not remain constant but varies with the change in specific gravity of electrolyte, temperature and the length of time since it was last charged. The emf of the cell increases with the increase in specific gravity of the electrolyte and vice versa but increase in specific gravity of the electrolyte also causes increase in internal resistance of the cell, therefore, its value should not go beyond 1.22. Best results are obtained with the electrolyte of specific gravity 1.21.

The emf of the cell, though, not much, but slightly increases with the increase in temperature.

The terminal voltage of battery is higher during charge than that during discharge.

2. Capacity: The quantity of electricity which a battery can deliver during single discharge until its terminal voltage falls to 1.8 V/cell is called the capacity of a battery. The capacity of cell is, therefore, expressed in *ampere-hours (A-H)* and is equal to the product of the specific discharge current in amperes multiplied by the number of hours before the cell discharges to the specific extent.

If I_d = Discharging Current in Ampere and
 T_d = Discharging Time of cell or battery in hours
 $C = I_d \times T_d$

3. Efficiency: The efficiency of the cell can be given in two ways:

1. The Quantity or Ampere - Hour (A-H) Efficiency: The ratio of output ampere-hour during discharging to the input ampere-hour during charging of the battery is called **quantity or ampere-hour** efficiency of the battery.

$$= \frac{I_d \times T_d}{I_c \times T_c} \times 100$$

Where I_d = Discharging Current in Ampere
 I_c = Charging Current in Ampere

T_d = Discharging Time of cell or battery in hours

T_c = Charging Time of cell or battery in hours

2. Energy or Watt - Hour (W-H) Efficiency: The ratio of output watt-hour during discharging to the input watt-hour during charging of the battery is called **energy or watt-hour** efficiency of the battery.

$$= \frac{V_d \times I_d \times T_d}{V_c \times I_c \times T_c} \times 100$$

Where V_d = Average Terminal Voltage during Discharging

V_c = Average Terminal Voltage during Charging

I_d = Discharging Current in Ampere

- = Charging Current in Ampere
- = Discharging Time of cell or battery in hours
- = Charging Time of cell or battery in hours

Elementary calculations for energy consumption and savings:

Electrical energy is supplied to a consumer by the supplier. To charge the electrical energy consumed by a consumer, an energy meter is installed to its quantity. The reading of the energy meter is taken every month. The difference between the fresh reading and the previous reading tell about the consumption of electrical energy in that month. This quantity of energy is multiplied by the rate (tariff) fixed by the supplier to prepare an electricity bill. However, some other charges such as meter rent, GST, other taxes applicable etc. are also added in the bill.

Battery Back-up:

The time (in hrs) for which a battery can deliver the desired current is called battery back-up of the bank.

