

Roll No. ....

Total Pages : 04

BT-6/M-19

36009

CONTROL SYSTEM  
ENGINEERING  
ECE-302E

Time : Three Hours]

[Maximum Marks : 100

Note : Attempt *Five* questions in all, selecting at least *one* question from each Unit.

Unit I

1. (a) Differentiate between open loop and closed loop control system with examples. 5
- (b) Explain for Mason's gain formula and its applications. 5
- (c) Find C/R for the control system shown in Fig. 2 below. 10

(3-81/7) L-36009 World

P.T.O.

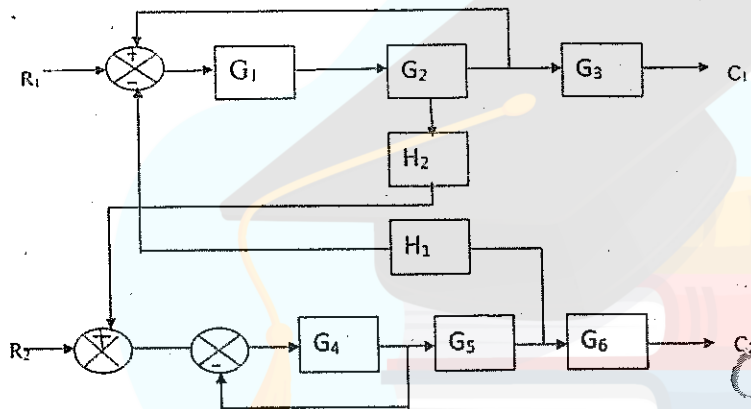

Fig. 2

2. (a) Draw and explain permanent-magnet stepper motor. 10
- (b) List and explain the various effects of using feedback in control systems. 10

## Unit II

3. (a) Derive and discuss the time response of second-order systems. 15
- (b) Using the Routh criterion, calculate the range of values of 'K' for the system to be stable. The open loop transfer function of a unity feedback control system is given as :

$$G(s) = \frac{K(s+13)}{s(s+3)(s+7)}$$

5

4. The characteristic equation of a feedback control system is :

$$s^4 + 3s^3 + 12s^2 + (K - 16)s + K = 0$$

Sketch the root locus plot for  $0 \leq K \leq \infty$  and show that the system is conditionally stable (stable for only a range of gain K). Determine the range of gain for which the system is stable. 20

### Unit III

5. (a) Draw the Bode Plot of the open loop transfer function of a unity feedback control system is : 15

$$G(s)H(s) = \frac{200(s+10)}{s(s+5)(s+20)}$$

Determine :

- (i) Gain Margin
  - (ii) Phase Margine
  - (iii) Closed loop stability. 15
- (b) Differentiate between Bode plot and Nyquist plot. 5
6. (a) Sketch the Polar Plot of the open loop transfer :

$$G(s) = \frac{1}{s(1+s)(1+2s)}$$

Determine whether these plots cross the real axis. If so, determine the frequency at which the plots cross the real axis and the corresponding magnitude

$$|G(j\omega)|. \quad \text{10}$$

- (b) Sketch the Nyquist Plot of the open loop transfer function of a unity feedback control system is :

$$G(s)H(s) = \frac{K}{s(s^2 + s + 4)}$$

If the system is conditionally stable, find the range of K for which the system is stable. **10**

#### Unit IV

7. A unity feedback system has an open loop transfer function :

$$G(s) = \frac{K}{s(1+s)(1+0.2s)}$$

Design phase-lag compensation for the system has velocity error constant  $K_v = 8 \text{ sec}^{-1}$ , phase margin =  $40^\circ$ . Also compare the cross-over frequency of the uncompensated and compensated systems.

8. A feedback system has a closed loop transfer function :

$$\frac{C(s)}{U(s)} = \frac{10(s+6)}{s(s+2)(s+4)}$$

Construct three different state models for this system and give block diagram representation for each state model.

**20**